

Transient Voltage Suppressors Diodes

Axial Leaded - 500W > SA5.0~180CA Series

The SA Series is designed specifically to protect sensitive electronic equipment from voltage transients induced by lightning and other transient voltage events.

Features

- Halogen-free
- Rohs compliant
- Typical maximum temperature coefficient
- $\Delta V_{BR} = 0.1\% \times V_{BR}@25^{\circ}\text{C} \times \Delta T$
- Glass passivated Chip junction in DO-15 package
- 500W peak pulse capability at $10 \times 1000\mu\text{s}$ waveform, repetition rate(duty cycles):0.01%
- Fast response time:typically less than 1.0ps from 0 Volts to BV min
- Excellent clamping capability
- Low incremental surge resistance
- Typical I_R less than $5\mu\text{A}$ above 11V
- High temperature soldering guaranteed: $260^{\circ}\text{C}/40$ seconds / $0.375''$,
- (9.5mm) lead length, 5lbs., (2.3kg) tension
- Plastic package has underwriters laboratory flammability classification 94v-0

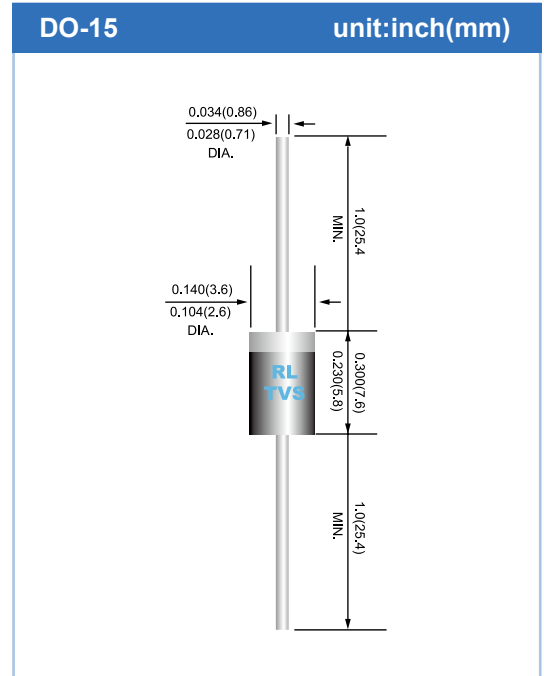

Applications

TVS devices are ideal for the protection of I/O interfaces, V_{CC} bus and other vulnerable circuits used in telecom,computer, industrial and consumer electronic applications.

Maximum Ratings And Characteristics (TA=25°C unless otherwise noted)

Rating	Symbol	Value	Units
Peak Pulse Power Dissipation by $10 \times 1000\mu\text{s}$ test waveform (Fig.1)(Note 1)	P_{PPM}	500	Watts
Steady State Power Dissipation on infinite heat sink at $T_L=75^{\circ}\text{C}$ (Fig. 5)	P_D	3	Watts
Peak Forward Surge Current, 8.3ms Single Half Sine Wave Unidirectional only (Note 2)	I_{FSM}	70	Amps
Maximum Instantaneous Forward Voltage at 25A for Unidirectional only (Note 3)	V_F	3.5/5.0	V
Operating junction and Storage Temperature Range.	T_J, T_{STG}	-55 to 175	$^{\circ}\text{C}$
Typical Thermal Resistance Junction to Lead	R_{wJL}	20	$^{\circ}\text{C}/\text{W}$
Typical Thermal Resistance Junction to Ambient	R_{wJA}	75	$^{\circ}\text{C}/\text{W}$
Operating junction and Storage Temperature Range.	T_J, T_{STG}	-55°C to +175°C	$^{\circ}\text{C}$

Notes:

1. Non-repetitive current pulse, per Fig. 3 and derated above $T_A = 25^{\circ}\text{C}$ per Fig. 2.
2. Measured on 8.3ms single half sine wave or equivalent square wave, duty cycle=4 per minute maximum.

Electrical Characteristics

Type Number		Reverse Stand-Off Voltage	Breakdown Voltage@I _T		Test Current	Maximum Clamping Voltage@I _{PP}	Peak Pulse Current	Reverse Leakage @V _{RWM}
(UNI)	(BI)	V _{RWM} (V)	V _{BR} MIN.(V)	V _{BR} MAX.(V)	I _T (mA)	V _C (V)	I _{PP} (A)	I _R (μA)
SA5.0A	SA5.0CA	5.0	6.40	7.00	10	9.2	55.4	600
SA6.0A	SA6.0CA	6.0	6.67	7.37	10	10.3	49.5	600
SA6.5A	SA6.5CA	6.5	7.22	7.98	10	11.2	45.5	400
SA7.0A	SA7.0CA	7.0	7.78	8.60	10	12.0	42.5	150
SA7.5A	SA7.5CA	7.5	8.33	9.21	1	12.9	39.5	50
SA8.0A	SA8.0CA	8.0	8.89	9.83	1	13.6	37.5	25
SA8.5A	SA8.5CA	8.5	9.44	10.40	1	14.4	35.4	10
SA9.0A	SA9.0CA	9.0	10.00	11.10	1	15.4	33.1	5
SA10A	SA10CA	10.0	11.10	12.30	1	17.0	30.0	5
SA11A	SA11CA	11.0	12.20	13.50	1	18.2	28.0	5
SA12A	SA12CA	12.0	13.30	14.70	1	19.9	25.6	5
SA13A	SA13CA	13.0	14.40	15.90	1	21.5	23.7	5
SA14A	SA14CA	14.0	15.60	17.20	1	23.2	22.0	5
SA15A	SA15CA	15.0	16.70	18.50	1	24.4	20.0	5
SA16A	SA16CA	16.0	17.80	19.70	1	26.0	19.6	5
SA17A	SA17CA	17.0	18.90	20.90	1	27.6	18.5	5
SA18A	SA18CA	18.0	20.00	22.10	1	29.2	17.5	5
SA20A	SA20CA	20.0	22.20	24.50	1	32.4	15.7	5
SA22A	SA22CA	22.0	24.40	26.90	1	35.5	14.4	5
SA24A	SA24CA	24.0	26.70	29.50	1	38.9	13.1	5
SA26A	SA26CA	26.0	28.90	31.90	1	42.1	12.1	5
SA28A	SA28CA	28.0	31.10	34.40	1	45.4	11.2	5
SA30A	SA30CA	30.0	33.30	36.80	1	48.4	10.5	5
SA33A	SA33CA	33.0	36.70	40.60	1	53.3	9.6	5
SA36A	SA36CA	36.0	40.00	44.20	1	58.1	8.8	5
SA40A	SA40CA	40.0	44.40	49.10	1	64.5	7.9	5
SA43A	SA43CA	43.0	47.80	52.80	1	69.4	7.3	5
SA45A	SA45CA	45.0	50.00	55.30	1	72.7	7.0	5
SA48A	SA48CA	48.0	53.30	58.90	1	77.4	6.6	5
SA51A	SA51CA	51.0	56.70	62.70	1	82.4	6.2	5
SA54A	SA54CA	54.0	60.00	66.30	1	87.1	5.0	5
SA58A	SA58CA	58.0	64.40	71.20	1	93.6	5.4	5
SA60A	SA60CA	60.0	66.70	73.70	1	96.8	5.3	5
SA64A	SA64CA	64.0	71.10	78.60	1	103.0	5.0	5
SA70A	SA70CA	70.0	77.80	86.00	1	113.0	4.5	5
SA75A	SA75CA	75.0	83.30	92.10	1	121.0	4.2	5
SA78A	SA78CA	78.0	86.70	95.80	1	126.0	4.0	5
SA85A	SA85CA	85.0	94.40	104.00	1	137.0	3.7	5
SA90A	SA90CA	90.0	100.00	111.00	1	146.0	3.5	5
SA100A	SA100CA	100.0	111.00	123.00	1	162.0	3.1	5
SA110A	SA110CA	110.0	122.00	135.00	1	177.0	2.0	5
SA120A	SA120CA	120.0	133.00	147.00	1	193.0	2.6	5
SA130A	SA130CA	130.0	144.00	159.00	1	209.0	2.4	5
SA150A	SA150CA	150.0	167.00	185.00	1	243.0	2.1	5
SA160A	SA160CA	160.0	178.00	197.00	1	259.0	2.0	5
SA170A	SA170CA	170.0	189.00	209.00	1	275.0	1.9	5
SA180A	SA180CA	180.0	200.00	233.00	1	289.0	1.7	5

Figure 1 - Peak Pulse Power Rating Curve

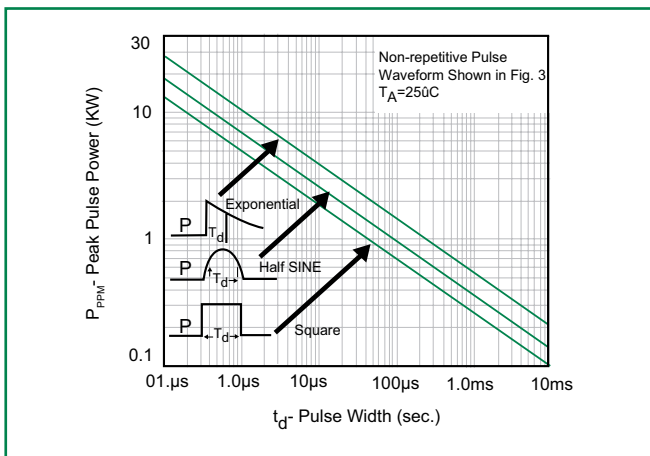

Figure 2 - Pulse Derating Curve

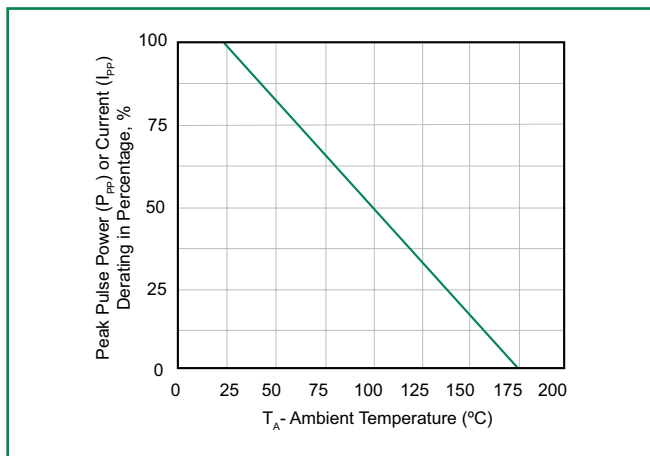

Figure 3 - Pulse Waveform

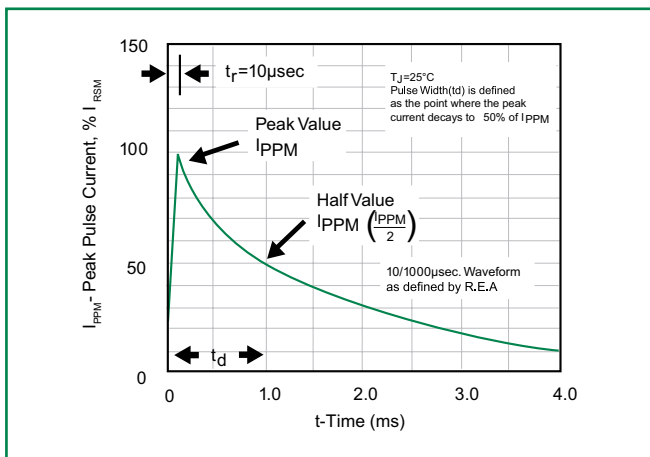

Figure 4 - Typical Junction Capacitance

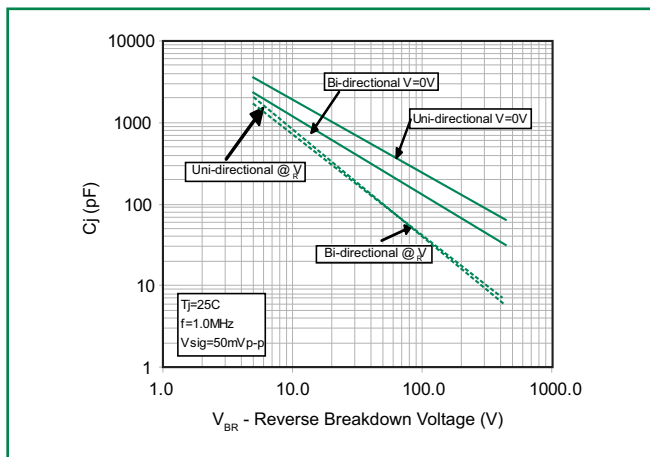

Figure 5 - Steady State Power Derating Curve

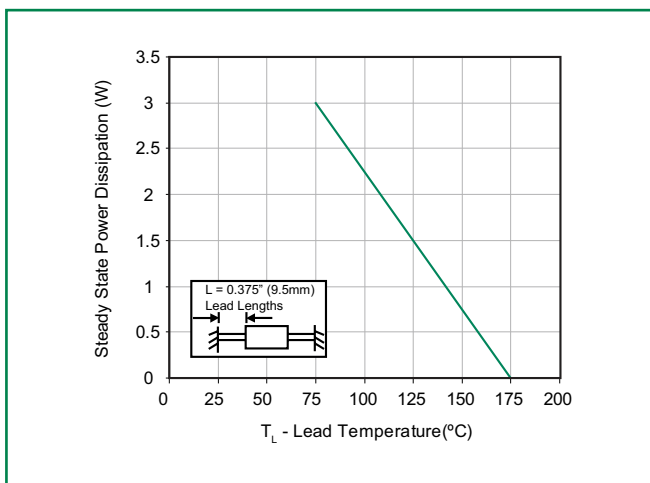
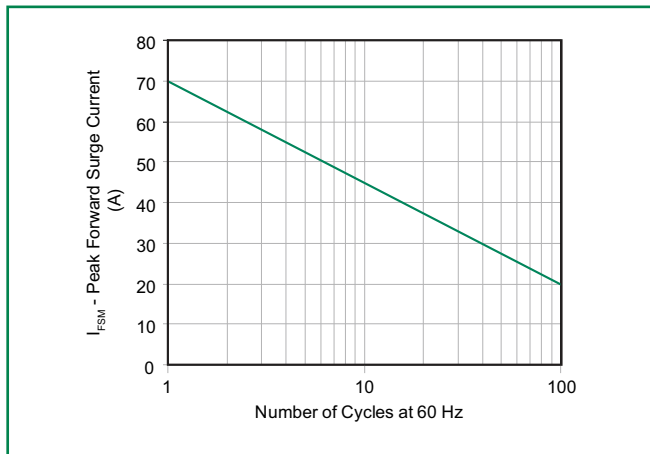
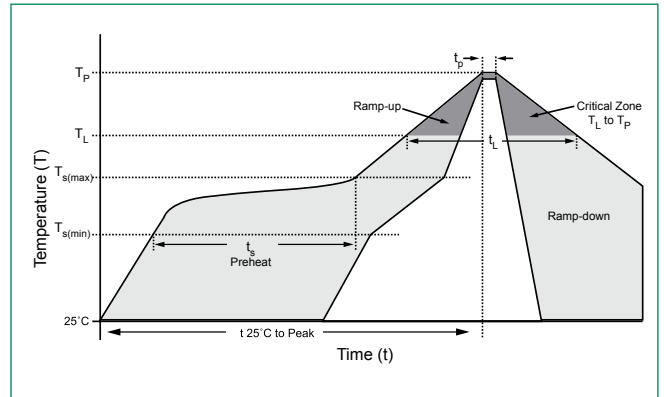

Figure 6 - Maximum Non-Repetitive Forward Surge Current Uni-Directional Only



Soldering Parameters

Reflow Condition		Lead-free assembly
Pre Heat	- Temperature Min ($T_{s(min)}$)	150°C
	- Temperature Max ($T_{s(max)}$)	200°C
	- Time (min to max) (t_s)	60 – 180 secs
Average ramp up rate (Liquidus Temp (T_L) to peak)		3°C/second max
$T_{s(max)}$ to T_L - Ramp-up Rate		3°C/second max
Reflow	- Temperature (T_L) (Liquidus)	217°C
	- Time (min to max) (t_s)	60 – 150 seconds
Peak Temperature (T_p)		260 ^{+0/-5} °C
Time within 5°C of actual peak Temperature (t_p)		20 – 40 seconds
Ramp-down Rate		6°C/second max
Time 25°C to peak Temperature (T_p)		8 minutes Max.
Do not exceed		280°C



Flow/Wave Soldering (Solder Dipping)

Peak Temperature :	265°C
Dipping Time :	10 seconds
Soldering :	1 time

Physical Specifications

Weight	0.045oz., 1.2g
Case	JEDEC DO-201 molded plastic body over passivated junction.
Polarity	Color band denotes the cathode except Bipolar.
Terminal	Matte Tin axial leads, solderable per JESD22-B102D.

Environmental Specifications

Temperature Cycle	JESD22-A104
Pressure Cooker	JESD 22-A102
High Temp. Storage	JESD22-A103
HTRB	JESD22-A108
Thermal Shock	JESD22-A106

Dimensions

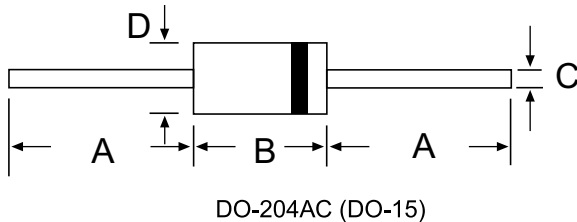

Dimensions	Inches		Millimeters	
	Min	Max	Min	Max
A	1.000	-	25.40	-
B	0.230	0.300	5.80	7.60
C	0.028	0.034	0.71	0.86
D	0.104	0.140	2.60	3.60

Part Numbering System

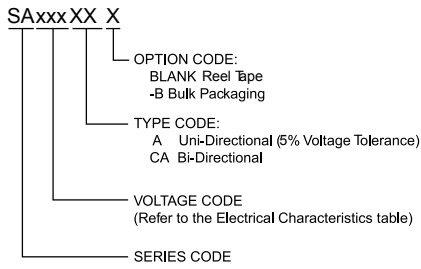

Part Marking System

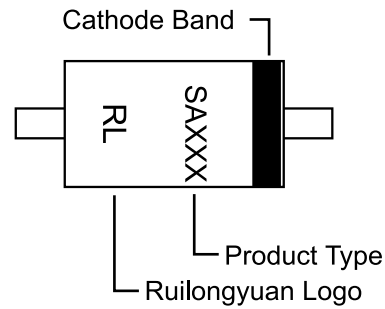

Packaging

Part Number	Component Package	Quantity	Packaging Option	Packaging Specification
SAxxxXX	DO-204AC	2000	Tape & Reel	EIA STD RS-296E
SAxxxXX-B	DO-204AC	500	Bulk	Concord Packing Spec

RUILONG.YUAN CO.,LTD
 Tel: +86- 0755-82908296
 Fax: +86- 0755-82908002

Email: jack@ruilon.com
 Website: <http://www.ruilon.com>

RuiLongYuan Electronics are trademarks.

Information furnished is believed to be accurate and reliable. However, users should independently evaluate the suitability of and test each product selected for their own applications. RUILONYUAN Electronics reserves the right to change or update, without notice, any information contained in this publication; to change, without notice, the design, construction, processing, or specification of any product; and to discontinue or limit production or distribution of any product. This publication supersedes and replaces all information previously supplied. Without expressed or written consent by an officer of RUILONYUAN Electronics, RUILONYUAN Electronics does not authorize the use of any of its products as components in nuclear facility applications, aerospace, or in critical life support devices or systems. RUILONYUAN Electronics expressly disclaims all implied warranties regarding the information contained herein, including, but not limited to, any implied warranties of merchantability or fitness for a particular purpose. RUILONYUAN Electronics' only obligations are those in the RUILONYUAN Electronics Standard Terms and Conditions of Sale and in no case will RUILONYUAN Electronics be liable for any incidental, indirect, or consequential damages.