



SGM9117

200MHz, Triple, 6dB Video Driver

PRODUCT DESCRIPTION

The SGM9117 includes triple high-speed video buffers with $G = +2$ in one package. Every video buffer has -3dB full signal bandwidth in excess of 200MHz, along with slew rates in excess of 300V/ μ s. With -65dB of crosstalk at 1MHz, the SGM9117 is useful in many high-speed applications. The differential gain and differential phase error are 0.01% and 0.02°. The SGM9117 is ideal for RGB and YPbPr signal buffering or driving. Operating from single power supply ranging from 2.5V to 5.5V and sinking an ultra-low 27.5mA quiescent current, the SGM9117 is also ideally suited for battery powered applications.

The SGM9117 is specified over the extended -40°C to +125°C temperature range. It is available in SOIC-8 package.

FEATURES

- Triple 200MHz Video Drivers
- Transparent Input Clamping
- 6dB Output Driver Gain and Drive Dual Video Loads
- Rail-to-Rail Output
- Input Voltage Range Includes Ground
- AC- or DC-Coupled Inputs
- AC- or DC-Coupled Outputs
- Operates from 2.5V to 5.5V Single Power Supply
- Low Power (9.2mA/Channel)
27.5mA Total Supply Current
- Available in Green SOIC-8 Package

APPLICATIONS

Video Amplifiers
Cable and Satellite Set-Top Boxes
Communication Devices
Video on Demand
Portable and Handheld Products
Personal Video Recorders
DVD Players
HDTV
Projectors

BLOCK DIAGRAM

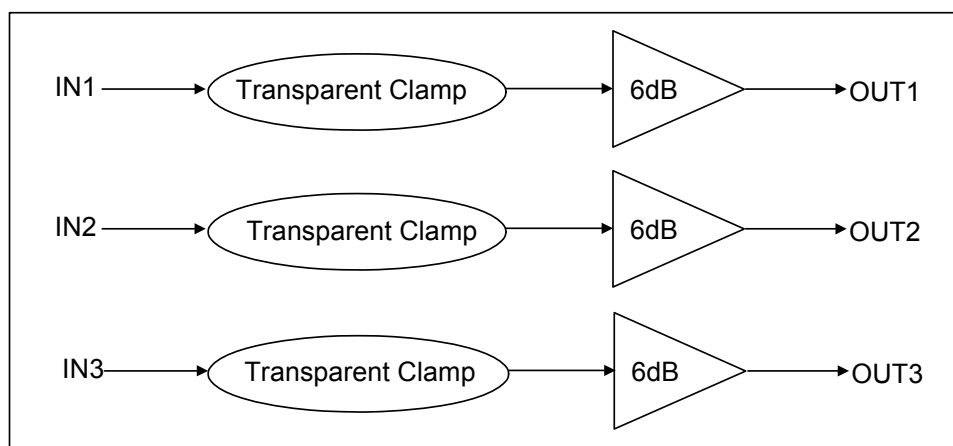

PACKAGE/ORDERING INFORMATION

ORDER NUMBER	PACKAGE DESCRIPTION	TEMPERATURE RANGE	PACKAGE OPTION	MARKING INFORMATION
SGM9117XS/TR	SOIC-8	-40°C to +125°C	Tape and Reel, 2500	SGM9117XS

PIN CONFIGURATION (TOP VIEW)

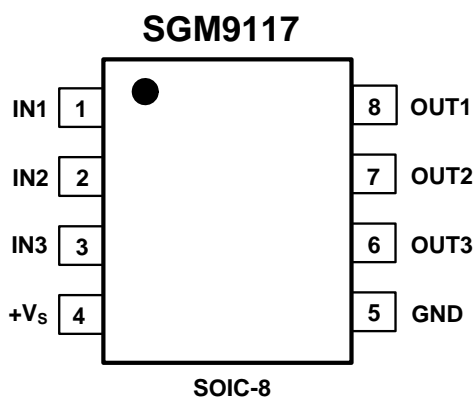

PIN DESCRIPTION

PIN	NAME	FUNCTION
1	IN1	Video Input. Channel 1.
2	IN2	Video Input. Channel 2.
3	IN3	Video Input. Channel 3.
4	+Vs	Power Supply.
5	GND	Ground.
6	OUT3	Video Output. Channel 3.
7	OUT2	Video Output. Channel 2.
8	OUT1	Video Output. Channel 1.

ABSOLUTE MAXIMUM RATINGS

Supply Voltage, +Vs to GND.....	7.5V
Input Voltage.....	GND - 0.3V to (+Vs) + 0.3V
Storage Temperature Range.....	-65°C to +150°C
Junction Temperature.....	160°C
Operating Temperature Range.....	-40°C to +125°C
Power Dissipation, P _D @ T _A = 25°C	
SOIC-8.....	0.8W
Package Thermal Resistance	
SOIC-8, θ _{JA}	128°C/W
Lead Temperature (Soldering 10 sec)	
.....	260°C
ESD Susceptibility	
HBM.....	4000V
MM.....	400V

NOTE:

Stresses beyond those listed under “Absolute Maximum Ratings” may cause permanent damage to the device. These are stress ratings only, and functional operation of the device at these or any other conditions beyond those indicated in the operational sections of the specifications is not implied. Exposure to absolute maximum rating conditions for extended periods may affect device reliability.

CAUTION

This integrated circuit can be damaged by ESD if you don’t pay attention to ESD protection. SGMICRO recommends that all integrated circuits be handled with appropriate precautions. Failure to observe proper handling and installation procedures can cause damage. ESD damage can range from subtle performance degradation to complete device failure. Precision integrated circuits may be more susceptible to damage because very small parametric changes could cause the device not to meet its published specifications.

SGMICRO reserves the right to make any change in circuit design, specification or other related things if necessary without notice at any time. Please contact SGMICRO sales office to get the latest datasheet.

ELECTRICAL CHARACTERISTICS: $V_S = +5.0V$ (At $R_L = 150\Omega$ connected to GND, $V_{IN} = 100mV_{PP}$ and $C_{IN} = 0.1\mu F$, all outputs AC-coupled with $220\mu F$, unless otherwise noted.)

PARAMETER	CONDITIONS	SGM9117							
		TYP	MIN/MAX OVER TEMPERATURE					UNITS	MIN/MAX
		+25°C	+25°C	0°C to 70°C	-40°C to +85°C	-40°C to +125°C			
INPUT CHARACTERISTICS									
Output Level Shift Voltage (V_{OLS})	$V_{IN} = 0V$, No load	261	348	355	365	395	mV	MAX	
Input Voltage Clamp (V_{CLAMP})	$I_{IN} = -1mA$	-4.3	-20	-22	-26	-29	mV	MIN	
Clamp Charge Current	$V_{IN} = V_{CLAMP} - 100mV$	-5.3	-6.8	-6.9	-7.5	-8.1	mA	MIN	
Voltage Gain (A_v)	$R_L = 150\Omega$	1.97	1.90	1.88	1.85	1.80	V/V	MIN	
			2.06	2.08	2.1	2.13	V/V	MAX	
OUTPUT CHARACTERISTICS									
Output Voltage High Swing	$V_{IN} = 3V$, $R_L = 150\Omega$ to GND	4.5	4.3	4.28	4.25	4.2	V	MIN	
Output Short-Circuit Current (I_{SC})	$V_{IN} = 3V$, to GND through 10Ω	-105	-102				mA	MAX	
	$V_{IN} = 100mV$, out shorted to $+V_S$ through 10Ω	115	103				mA	MIN	
POWER SUPPLY									
Operating Voltage Range			2.5	2.7	2.7	2.7	V	MIN	
			5.5	5.5	5.5	5.5	V	MAX	
Power Supply Rejection Ratio (PSRR)	$V_S = 2.7V$ to $5.5V$	62	49	48	45	44	dB	MIN	
Quiescent Current (I_Q)	$V_{IN} = 500mV$	27.5	31.5	32	33	34	mA	MAX	
DYNAMIC PERFORMANCE									
$\pm 0.1dB$ Bandwidth	$R_L = 150\Omega$	92					MHz	TYP	
-3dB Bandwidth	$R_L = 150\Omega$	200					MHz	TYP	
Slew Rate	20% to 80%, $V_{IN} = 1V$ Step	300					V/ μs	TYP	
Differential Gain (DG)	NTSC & PAL DC-coupled	0.01					%	TYP	
	NTSC & PAL AC-coupled	0.46					%	TYP	
Differential Phase (DP)	NTSC & PAL DC-coupled	0.02					°	TYP	
	NTSC & PAL AC-coupled	0.8					°	TYP	
Group Delay Variation (D/DT)	$f = 400kHz$, $26.5MHz$	3.0					ns	TYP	
Crosstalk (channel-to-channel)	at $1MHz$	-65					dB	TYP	
Fall Time	$2.0V_{STEP}$, 80% to 20%	5.0					ns	TYP	
Rise Time	$2.0V_{STEP}$, 80% to 20%	5.1					ns	TYP	

TYPICAL PERFORMANCE CHARACTERISTICS

At $V_S = +5.0V$, $T_A = +25^\circ C$, $R_L = 150\Omega$, all outputs AC-coupled with $220\mu F$, unless otherwise noted.

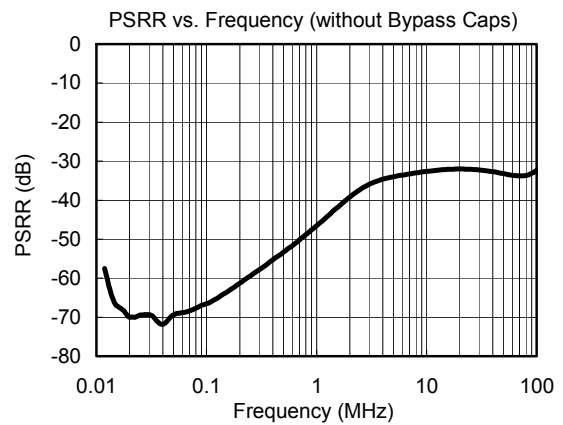
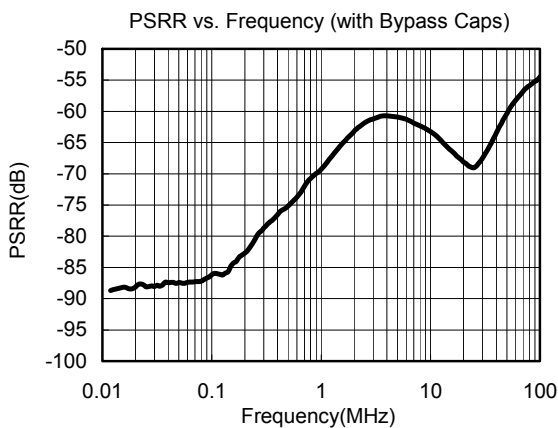
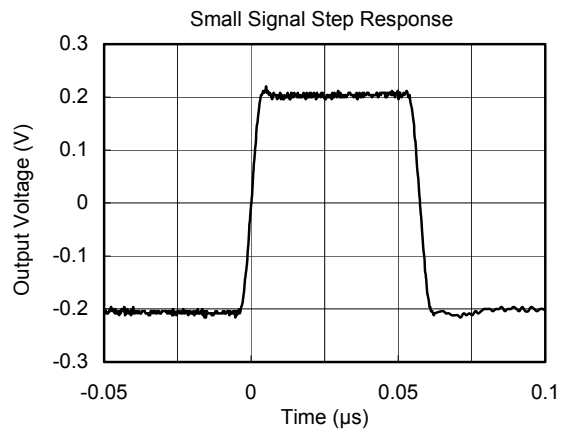
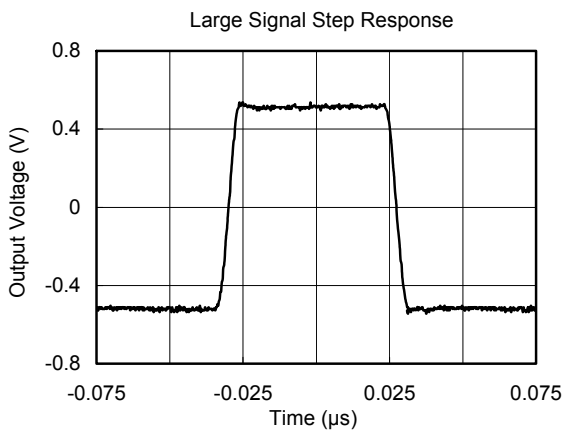
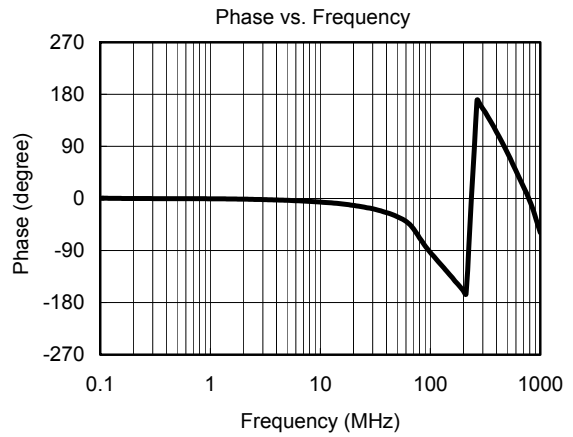
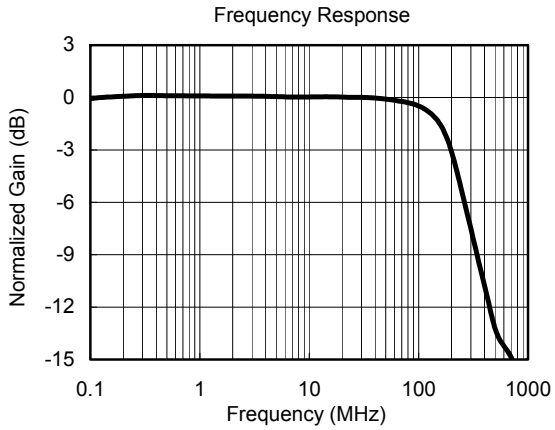

TYPICAL PERFORMANCE CHARACTERISTICS

At $V_S = +5.0V$, $T_A = +25^\circ C$, $R_L = 150\Omega$, all outputs AC-coupled with $220\mu F$, unless otherwise noted.

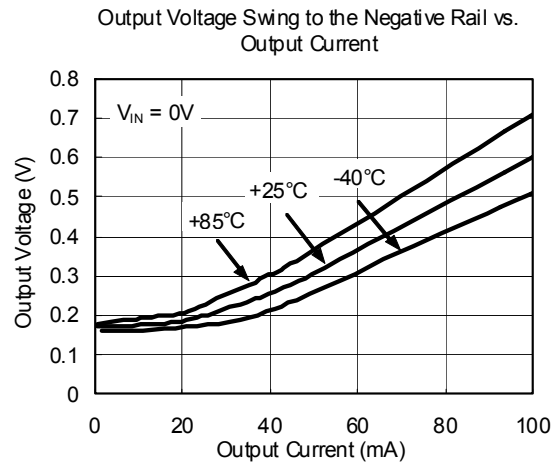
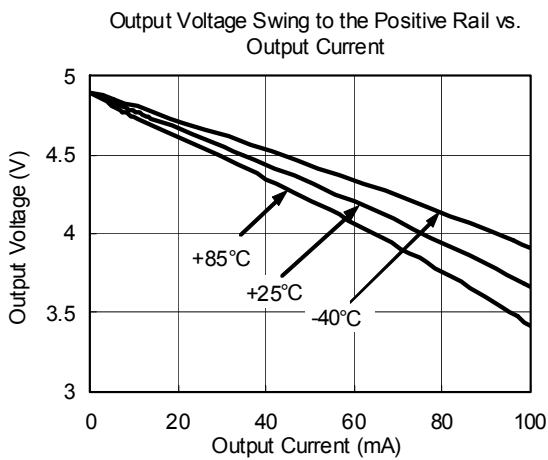
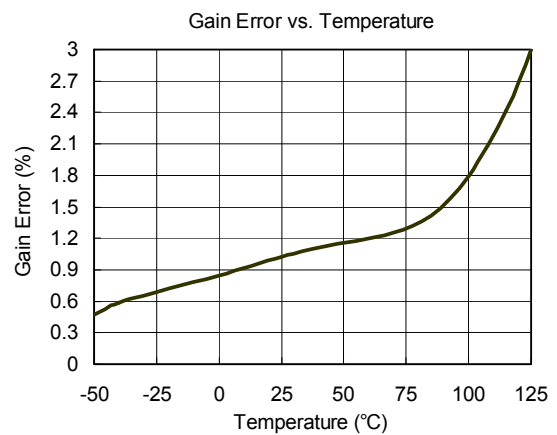
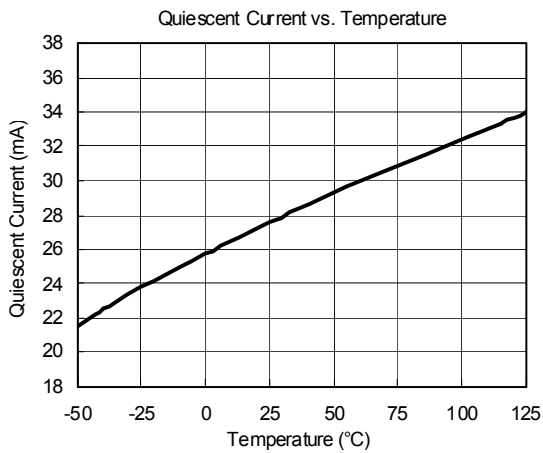
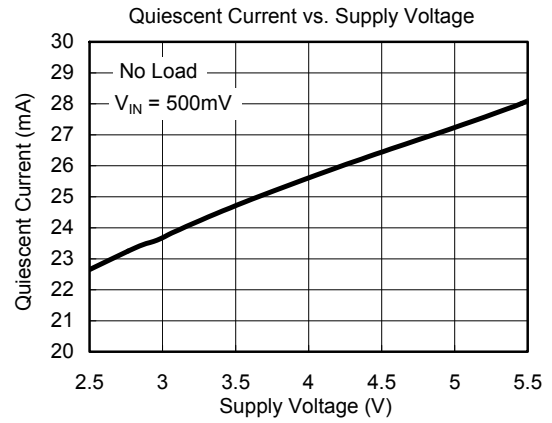
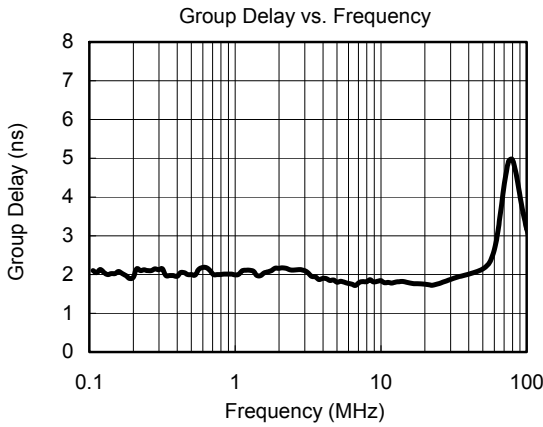

APPLICATION INFORMATION

Functional Description

SGM9117 operates from a single 2.5V to 5V supply. In application, SGM9117 is a fully integrated solution for buffering RGB or HDTV component signals in front of video decoder or behind video encoder. For example, SGM9117 can replace three amplifier drivers at R\GB and Y\Pb\Pr output side in set-top box, Monitor and LCD TV. This solution can help reduce PCB size and production cost, and it also improves video signal performance comparing with traditional design using discrete components. SGM9117 features a DC-coupled input buffer, and a gain of 6dB in the output amplifier to drive 75Ω load. The AC- or DC-coupled input buffer eliminates sync crush, droop, and field tilt. The output of SGM9117 also can be DC-coupled or AC-coupled.

Input Considerations

Besides AC coupling, the SGM9117 inputs also can be DC-coupled. In DC coupling application, no input coupling capacitors are needed because the amplitude of input video signal from DAC includes ground and extends up to 1.4V, and SGM9117 can be directly connected to the output of a single-supply, current-output DAC without any external bias network. In applications where DAC's output level exceeds the range from 0V to 1.4V, or SGM9117 is driven by an unknown external source or a SCART switch which has its own clamping circuit, AC coupling is needed.

Output Considerations

The SGM9117 outputs can be DC-coupled or AC-coupled. When input is 0V, the SGM9117 output voltage is 260mV typically. In DC coupling design, one 75Ω resistor is used to connect SGM9117's output pin with external load directly, and this serial back-termination resistor is used to match the impedance of the transmission line between SGM9117 and external load to cancel the signal reflection. The SGM9117 outputs can sink and source current allowing the device to be AC-coupled with external load. In AC coupling, at least 220μF capacitor will be used in order to cancel field tilt.

Power-Supply Bypassing and Layout

Correct power supply bypassing is very important for optimizing video performance in design. One 0.1μF and one 10μF capacitors are always used to bypass +V_S pin of SGM9117. Place these two capacitors as close to the SGM9117 supply pin as possible. A large ground plane is also needed to ensure optimum performance. The input and output termination resistors should be placed as close to the related pins of SGM9117 as possible to avoid performance degradation. The PCB traces at the output side should have 75Ω characteristic impedance in order to match the 75Ω characteristic impedance of the cable connecting external load. In design, keep the board trace at the inputs and outputs of the SGM9117 as short as possible to minimize the parasitic stray capacitance and noise pickup. Designer needs to cavern out the ground layer under input and output trace in order to reduce stray capacitance and avoid signal peaking.

APPLICATION INFORMATION

Typical Application Diagram

The circuit in Figure 2 is normally used for AC-coupled output and DC-coupled input with DAC which has an output voltage range from 0V to 1.4V. AC-coupled output offers slightly lower power dissipation.

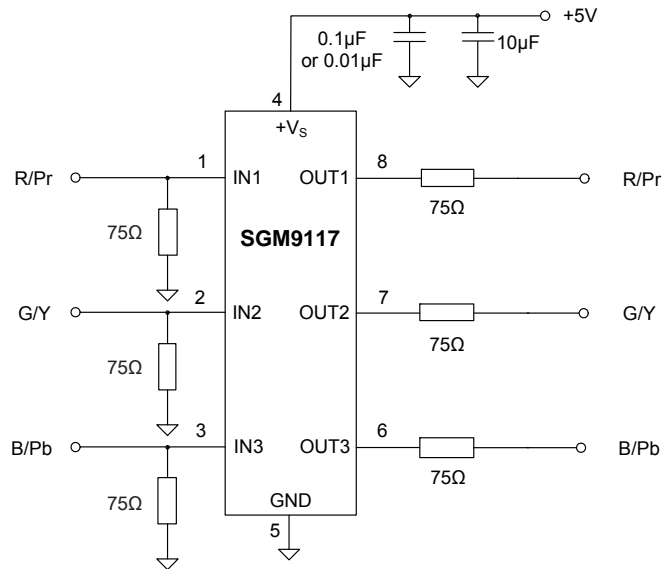

Figure 1. DC Coupling Circuit

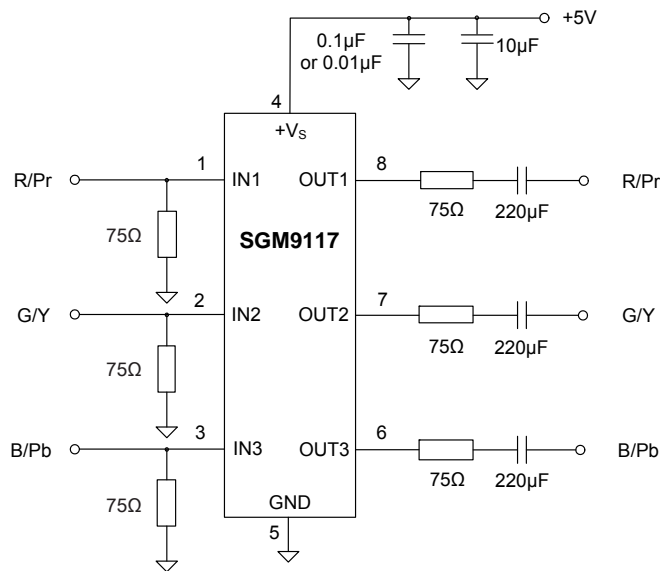

Figure 2. Input DC and Output AC Coupling Circuit

NOTE:

1. Power supply +Vs must be sequenced on first before input video signals.

PACKAGE OUTLINE DIMENSIONS

SOIC-8

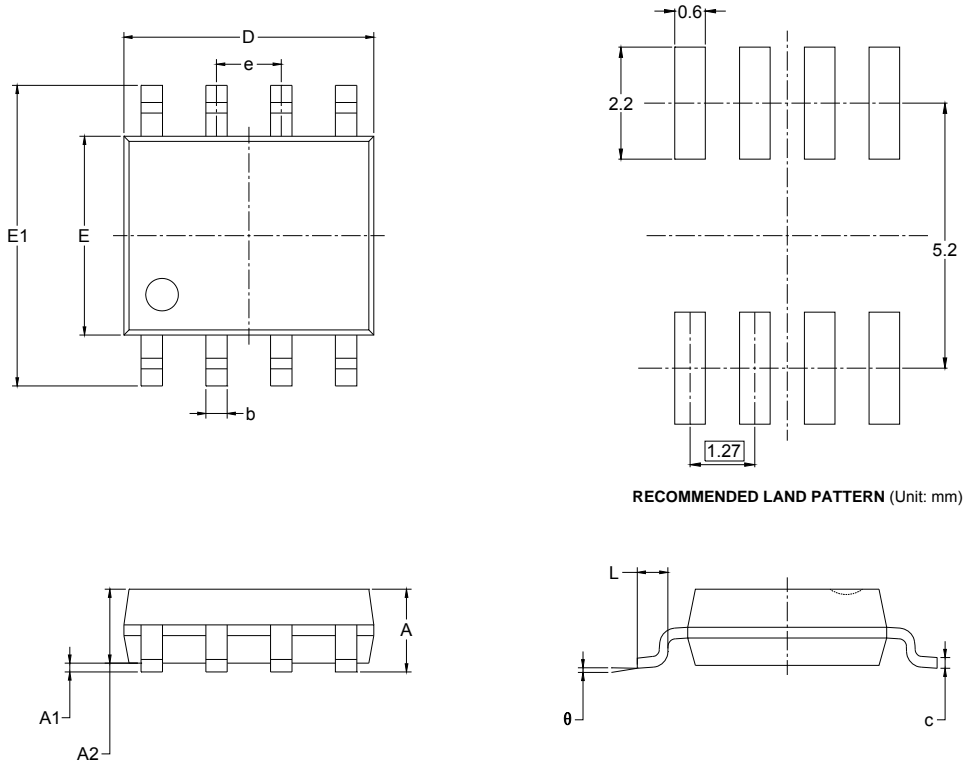

RECOMMENDED LAND PATTERN (Unit: mm)

Symbol	Dimensions In Millimeters		Dimensions In Inches	
	MIN	MAX	MIN	MAX
A	1.350	1.750	0.053	0.069
A1	0.100	0.250	0.004	0.010
A2	1.350	1.550	0.053	0.061
b	0.330	0.510	0.013	0.020
c	0.170	0.250	0.006	0.010
D	4.700	5.100	0.185	0.200
E	3.800	4.000	0.150	0.157
E1	5.800	6.200	0.228	0.244
e	1.27 BSC		0.050 BSC	
L	0.400	1.270	0.016	0.050
θ	0°	8°	0°	8°

TAPE AND REEL INFORMATION

REEL DIMENSIONS

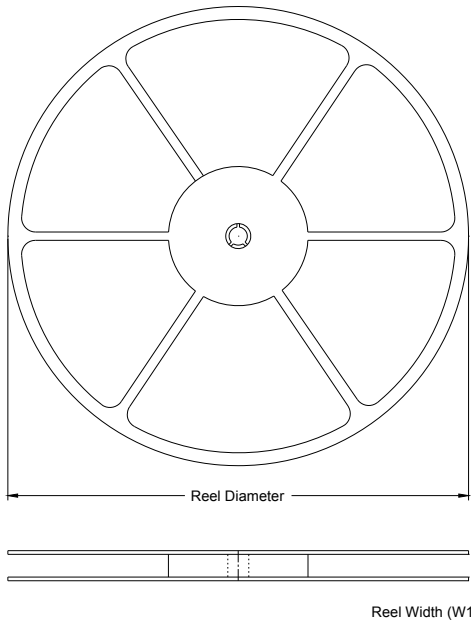

TAPE DIMENSIONS

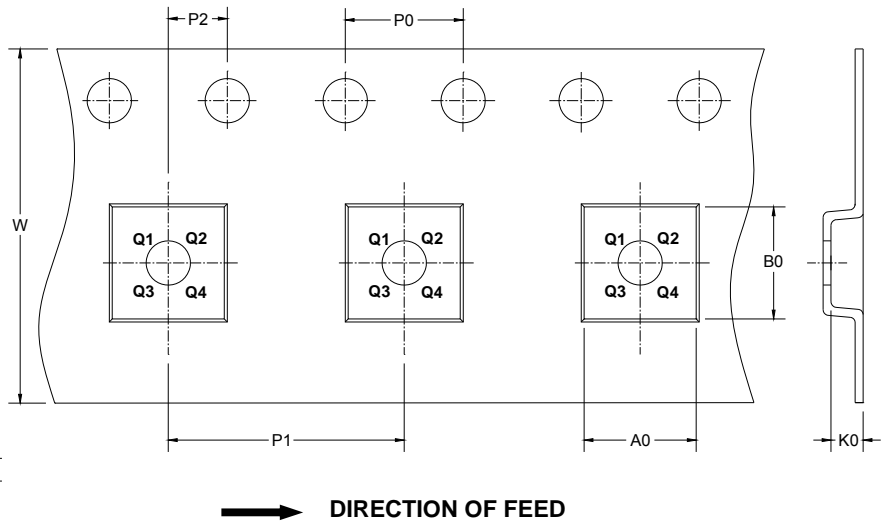

NOTE: The picture is only for reference. Please make the object as the standard.

KEY PARAMETER LIST OF TAPE AND REEL

Package Type	Reel Diameter	Reel Width W1 (mm)	A0 (mm)	B0 (mm)	K0 (mm)	P0 (mm)	P1 (mm)	P2 (mm)	W (mm)	Pin1 Quadrant
SOIC-8	13"	12.4	6.4	5.4	2.1	4.0	8.0	2.0	12.0	Q1

CARTON BOX DIMENSIONS

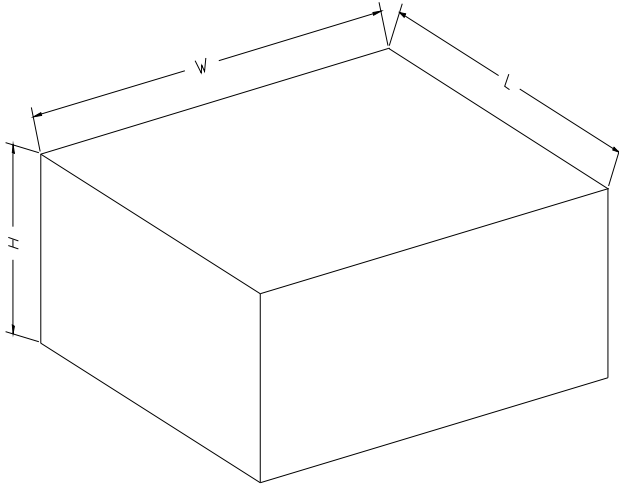

NOTE: The picture is only for reference. Please make the object as the standard.

KEY PARAMETER LIST OF CARTON BOX

Reel Type	Length (mm)	Width (mm)	Height (mm)	Pizza/Carton
13"	386	280	370	5