

MAPX	MODIFICATION	DATE

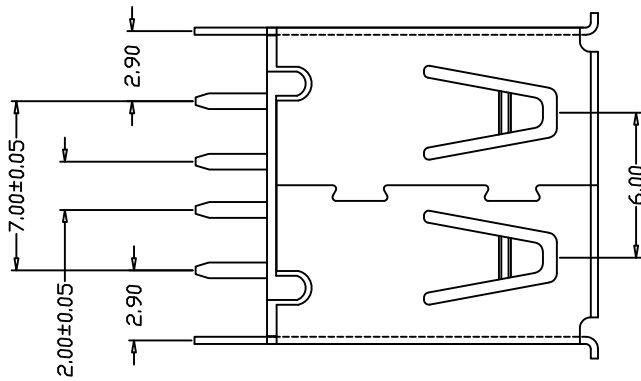
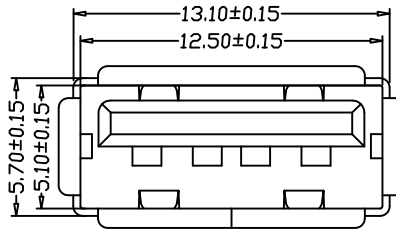
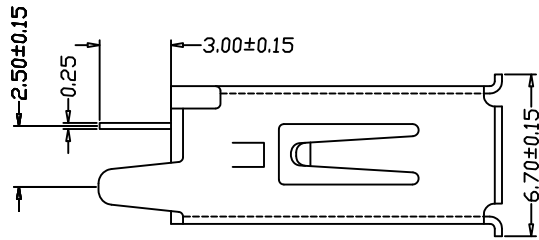
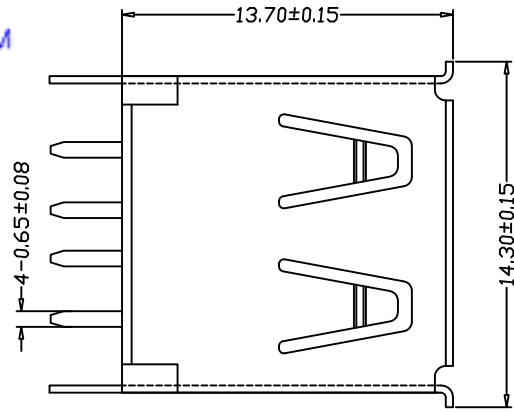

NOTES:

- 1. HOUSING: SEE NOTES,
- TERMINAL: SEE NOTES.
- SHELL: SEE NOTES.

SPECIFICATION:

- 1. ELECTRICAL CHARACTERISTIC:
 - CONTACT RESISTANCE: 30MΩ MAX
 - DIELECTRIC WITHSTANDING VOLTAGE: 500V AC FOR 1MIN
 - INSULATION RESISTANCE: 1000MΩ MIN
- 2. MECHANICAL CHARACTERISTIC:
 - INSERTION FORCE: 35N(3.57KGF) MAX
 - EXTRACTION FORCE: 10~35N(1.02~3.57KGF)MIN
 - DURABILITY: 1500 CYCLES EXTRACTION FORCE:10~35N
 - 5000 CYCLES MIN
 - 5000 CYCLES EXTRACTION FORCE:3~35N

3. ENVIRONMENTAL:

OPERATING TEMPERATURE: -55°C+85°C

4. Contact finish:

- 01:Selective Gold Flash
- 02:Selective Gold 3U"
- 03:Selective Gold 5U"
- 04:Selective Gold 15U"
- 05:Selective Gold 30U"

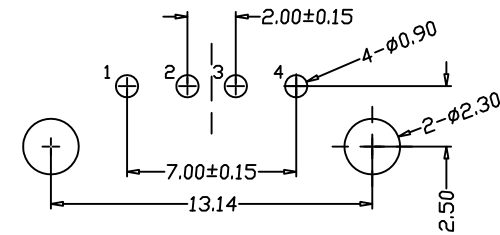

PCB LAYOUT

<p>产品图 PRODUCT CHART DWG</p> <p>公差一览表 TOLERANCE UNLESS OTHERWISE</p> <table border="1"> <tr> <td>X.</td> <td>±0.25</td> <td>X.</td> <td>±5.°</td> </tr> <tr> <td>.X</td> <td>±0.20</td> <td>.XX</td> <td>±2.°</td> </tr> <tr> <td>.XX</td> <td>±0.15</td> <td>.XXX</td> <td>±1.°</td> </tr> <tr> <td>.XXX</td> <td>±0.10</td> <td>.XXX</td> <td>±0.5°</td> </tr> </table>				X.	±0.25	X.	±5.°	.X	±0.20	.XX	±2.°	.XX	±0.15	.XXX	±1.°	.XXX	±0.10	.XXX	±0.5°	<p>单位 UNITS</p> <p>MM</p>	<p>制图 DRAWING</p> <p>Z-Y-B</p>	<p>制图料号 PRODUCT PART NO.</p>
X.	±0.25	X.	±5.°																			
.X	±0.20	.XX	±2.°																			
.XX	±0.15	.XXX	±1.°																			
.XXX	±0.10	.XXX	±0.5°																			
<p>比例 SCALE</p> <p>1:1</p>		<p>审核 CHKD</p>	<p>产品名称 PRODUCT NAME</p> <p>C39457</p>																			
<p>日期 DATE</p> <p>2014.07.24</p>	<p>核准 APPD</p>	<p>角法 VIEW</p>	<p>版本 VER</p> <p>AD</p>																			