

D款, 正向10.6前两脚, DIP-\*6.80

MAPX	MODIFICATION	DATE

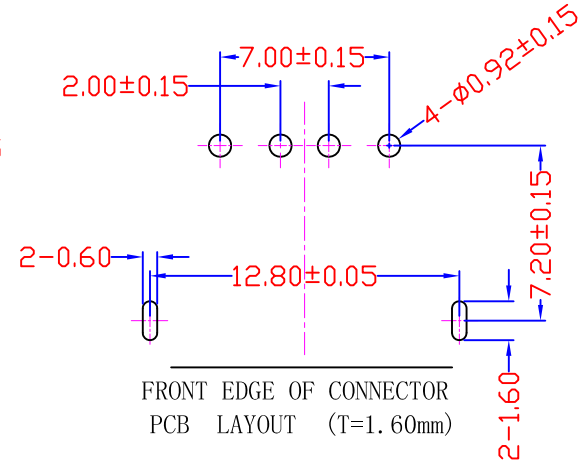
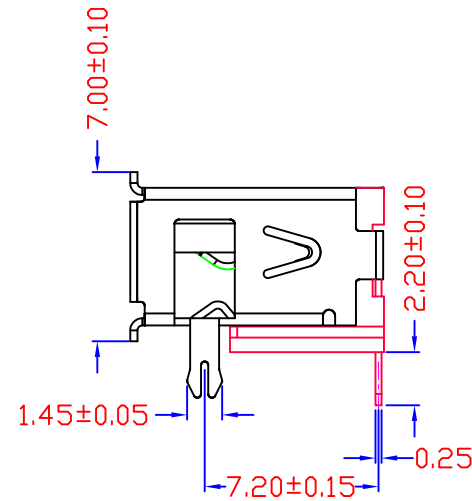
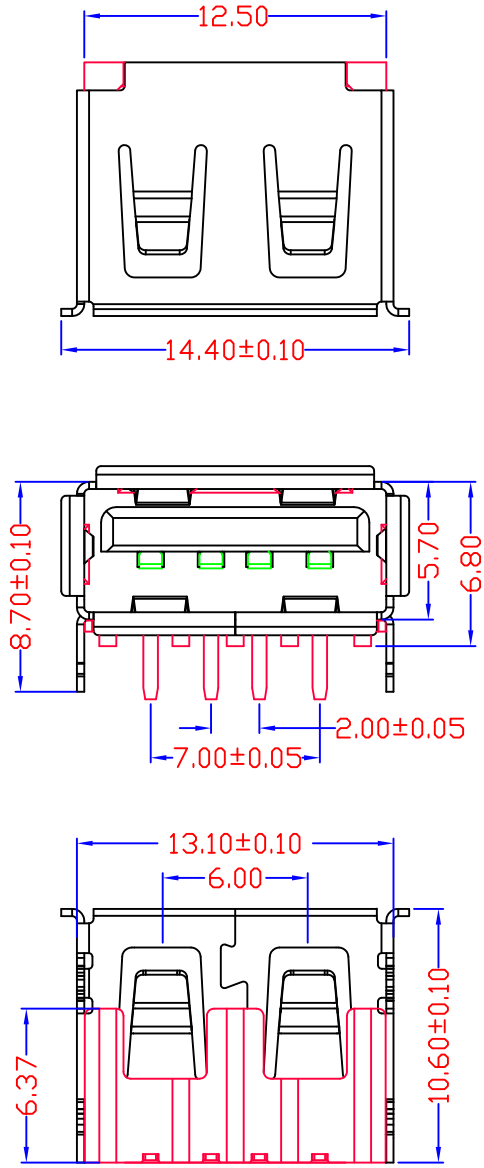

NOTES:  
 1. HOUSING: SEE NOTES, UL94V-0 .  
 TERMINAL: SEE NOTES.  
 SHELL: SEE NOTES.

SPECIFICATION:  
 1. ELECTRICAL CHARACTERISTIC:  
 CONTACT RESISTANCE: 30MΩ MAX  
 DIELECTRIC WITHSTANDING VOLTAGE: 500V AC FOR 1MIN  
 INSULATION RESISTANCE: 1000MΩ MIN  
 2. MECHANICAL CHARACTERISTIC:  
 INSERTION FORCE: 35N(3.57KGF) MAX  
 EXTRACTION FORCE: 10~35N(1.02~3.57KGF)MIN  
 DURABILITY: 1500 CYCLES EXTRACTION FORCE:10~35N  
 5000 CYCLES EXTRACTION FORCE:3~35N  
 3. ENVIRONMENTAL:  
 OPERATING TEMPERATURE: -55℃+85℃  
 4. Contact finish:  
 01:Selective Gold Flash  
 02:Selective Gold 3U"  
 03:Selective Gold 5U"  
 04:Selective Gold 15U"  
 05:Selective Gold 30U"

FRONT EDGE OF CONNECTOR  
PCB LAYOUT (T=1.60mm)

产品图 PRODUCT CHART DWG										
公差一览表 TOLERANCE UNLESS OTHERWISE				单位 UNITS	MM	制图 DRAWING	Z-Y-B	制图料号 PRODUCT PART NO.	JTJ-USB-10.6-001	
X.	±0.15	X.	±5°	比例 SCALE	1:1	审核 CHKD		产品名称 PRODUCT NAME	USB A/F 10.6有边前两脚鱼叉(方弹)	
.XX	±0.05	.XX	±1°	日期 DATE	2012.09.24	核准 APPD		角法 VIEW	版本 VER	AD
.XXX	±0.03	.XXX	±0.5°							