

D款, 正向10.6前两脚, DIP-*6.20

| | | |
|------|--------------|------|
| MAPX | MODIFICATION | DATE |
| | | |

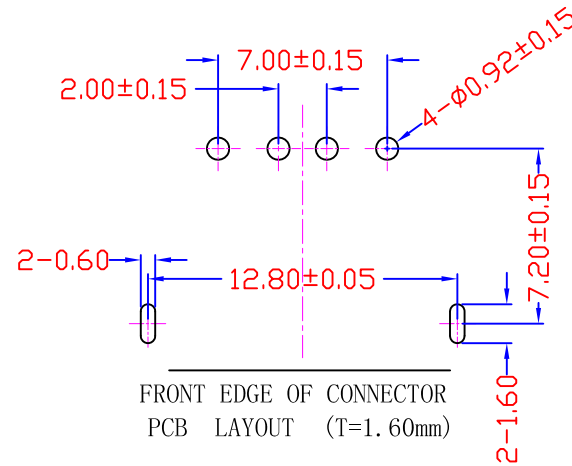
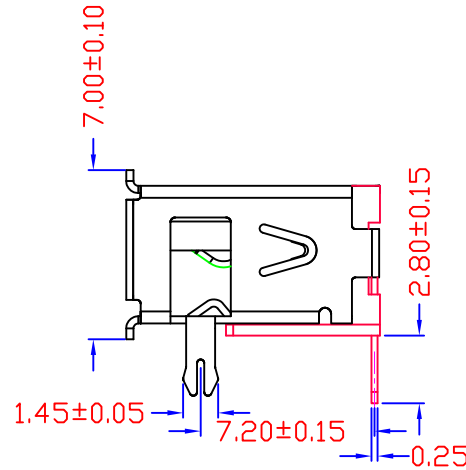
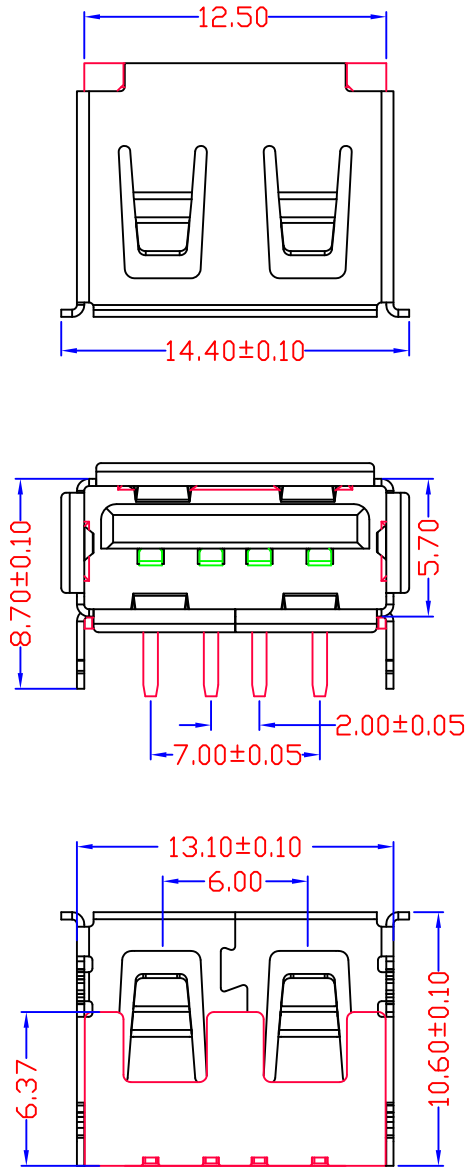

NOTES:

- HOUSING: SEE NOTES, UL94V-0 .
- TERMINAL: SEE NOTES.
- SHELL: SEE NOTES.

SPECIFICATION:

1. ELECTRICAL CHARACTERISTIC:

- CONTACT RESISTANCE: 30MΩ MAX
- DIELECTRIC WITHSTANDING VOLTAGE: 500V AC FOR 1MIN
- INSULATION RESISTANCE: 1000MΩ MIN

2. MECHANICAL CHARACTERISTIC:

- INSERTION FORCE: 35N(3.57KGF) MAX
- EXTRACTION FORCE: 10~35N(1.02~3.57KGF)MIN
- DURABILITY: 1500 CYCLES EXTRACTION FORCE:10~35N 5000 CYCLES EXTRACTION FORCE:3~35N

3. ENVIRONMENTAL:

- OPERATING TEMPERATURE: -55℃+85℃

4. Contact finish:

- 01:Selective Gold Flash
- 02:Selective Gold 3U"
- 03:Selective Gold 5U"
- 04:Selective Gold 15U"
- 05:Selective Gold 30U"

| | | | | | | | | | | |
|-------------------------------------|-------|------|-------|-------------|------------|---------------|-------|-------------------------|-------------------------|----|
| 产品图 PRODUCT CHART DWG | | | | | | | | | | |
| 公差一览表 TOLERANCE UNLESS OTHERWISE | | | | 单位 UNITS | MM | 制图 DRAWING | Z-Y-B | 制图料号 PRODUCT PART NO | JTJ-USB-10.6-001 | |
| X. | ±0.15 | X. | ±5.° | 比例 SCALE | 1:1 | 审核 CHKD | | 产品名称 PRODUCT NAME | USB A/F 10.6有边前两脚鱼叉(方弹) | |
| .X | ±0.10 | .X | ±2.° | 日期 DATE | 2012.09.24 | 核准 APPD | | 角法 VIEW | 版本 VER | AD |
| .XX | ±0.05 | .XX | ±1.° | | | | | | | |
| .XXX | ±0.03 | .XXX | ±0.5° | | | | | | | |