

D款, 正向10.6四脚, SMT-\*6.20

MAPX	MODIFICATION	DATE

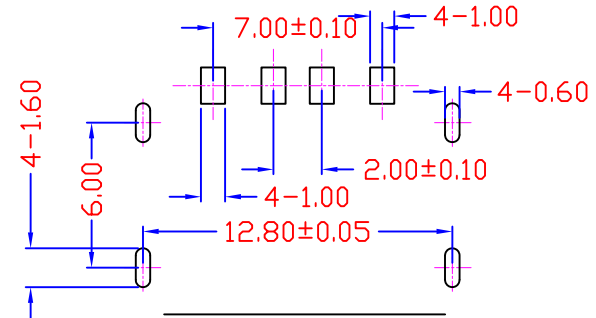
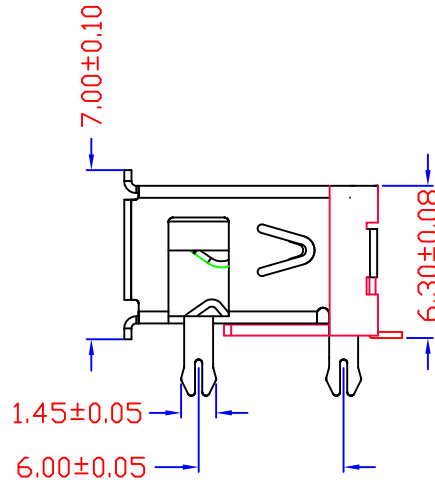
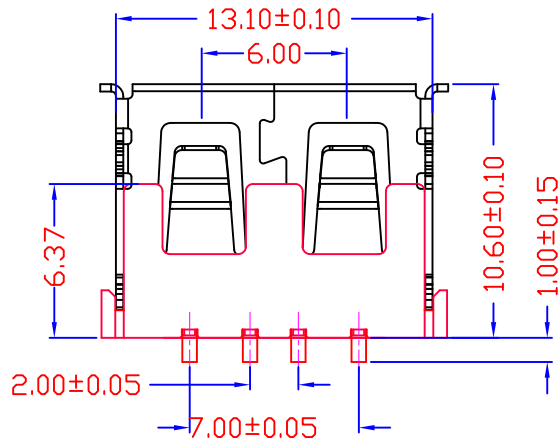
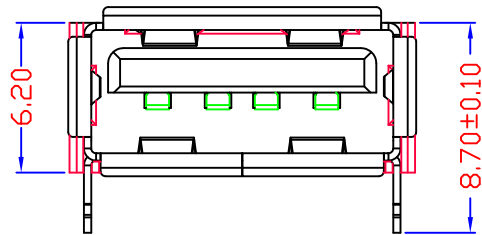
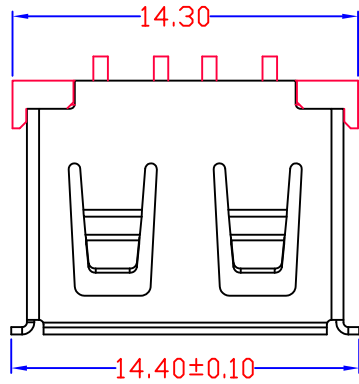

NOTES:  
 1.HOUSING: SEE NOTES, UL94V-0 .  
 TERMINAL: SEE NOTES.  
 SHELL: SEE NOTES.  
 SPECIFICATION:  
 1.ELECTRICAL CHARACTERISTIC:  
 CONTACT RESISTANCE: 30mΩ MAX  
 DIELECTRIC WITHSTANDING VOLTAGE: 500V AC FOR 1MIN  
 INSULATION RESISTANCE: 1000MΩ MIN  
 2.MECHANICAL CHARACTERISTIC:  
 INSERTION FORCE: 35N(3.57KGF) MAX  
 EXTRACTION FORCE: 10~35N(1.02~3.57KGF)MIN  
 DURABILITY: 1500 CYCLES EXTRACTION FORCE:10~35N  
 5000 CYCLES MIN  
 5000 CYCLES EXTRACTION  
 FORCE: 3~35N  
 3.ENVIRONMENTAL:  
 OPERATING TEMPERATURE: -55℃+85℃  
 4.Contact finish:  
 01: Selective Gold Flash  
 02: Selective Gold 3U"  
 03: Selective Gold 5U"  
 04: Selective Gold 15U"  
 05: Selective Gold 30U"

FRONT EDGE OF CONNECTOR  
 PCB LAYOUT (T=1.60mm)

产品图 PRODUCT CHART DWG				单位 UNITS		MM	制图 DRAWING	Z-Y-B	制图料号 PRODUCT PART NO.	JTJ-USB-10.6-001	
公差一览表 TOLERANCE UNLESS OTHERWISE				比例 SCALE		1:1	审核 CHKD		产品名称 PRODUCT NAME	USB A/F 10.6有边四脚鱼叉(方弹)	
X.	±0.25	X.	±5.°	日期 DATE		2012.09.24	核准 APPD		角法 VIEW	版本 VER	AD
.X	±0.20	.X	±2.°								
.XX	±0.15	.XX	±1.°								
.XXX	±0.10	.XXX	±0.5°								