

# D款, 反向10.0四脚, DIP-\*6.50

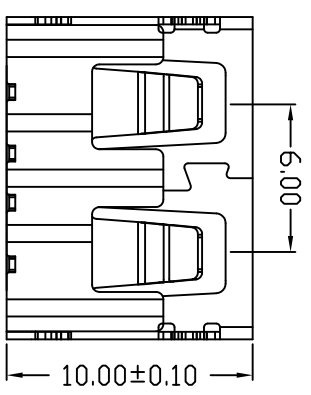
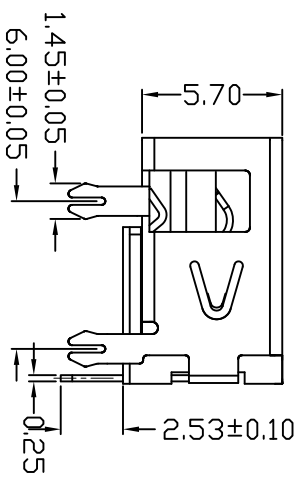
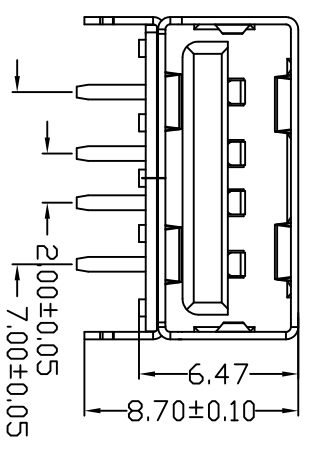
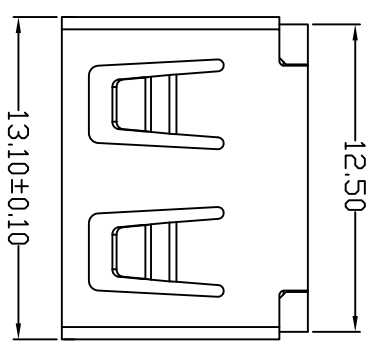

MAPX	MODIFICATION	DATE
------	--------------	------

NOTES:  
1. HOUSING: SEE NOTES, UL94V-0.

TERMINAL: SEE NOTES.  
SHELL: SEE NOTES.

SPECIFICATION:

- ELECTRICAL CHARACTERISTIC:  
CONTACT RESISTANCE: 30MΩ MAX  
DIELECTRIC WITHSTANDING VOLTAGE: 500V AC FOR 1MIN  
INSULATION RESISTANCE: 1000MΩ MIN
- MECHANICAL CHARACTERISTIC:  
INSERTION FORCE: 35N(3.57KGF) MAX  
EXTRACTION FORCE: 10~35N(1.02~3.57KGF) MIN  
DURABILITY: 1500 CYCLES EXTRACTION FORCE: 10~35N  
5000 CYCLES MIN
- ENVIRONMENTAL:  
OPERATING TEMPERATURE: -55°C~+85°C
- Contact finish:

- Selective Gold Flash
- Selective Gold 3U"
- Selective Gold 5U"
- Selective Gold 15U"
- Selective Gold 30U"

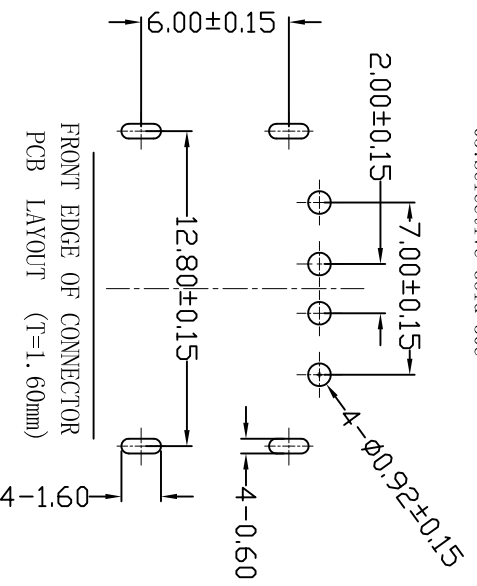

产品图  
PRODUCT CHART DWG

公差一览表  
TOLERANCE UNLESS OTHERWISE

X	±0.15	X	±5.°
X	±0.10	X	±2.°
XX	±0.05	XX	±1.°
XXX	±0.03	XXX	±0.5°

单位	MM	制图	Z-Y-B	制图料号	JTJ-USB-10.0-003
比例	1:1	审核		产品名称	USB A/F 10.0无边四脚鱼叉(方弹)
日期	2015.09.24	核准		角法	
DATE		APPD		版本	AD

1 2 3 4 5 6 7 8 9 10