

MAPX	MODIFICATION	DATE

NOTES:
 1. HOUSING: SEE NOTES,
 TERMINAL: SEE NOTES,
 SHELL: SEE NOTES.
 SPECIFICATION:
 1. ELECTRICAL CHARACTERISTIC:
 CONTACT RESISTANCE: 30MΩ MAX
 DIELECTRIC WITHSTANDING VOLTAGE: 500V AC FOR 1MIN
 INSULATION RESISTANCE: 1000MΩ MIN
 2. MECHANICAL CHARACTERISTIC:
 INSERTION FORCE: 35N(3.57KGF) MAX
 EXTRACTION FORCE: 10~35N(1.02~3.57KGF)MIN
 DURABILITY: 1500 CYCLES EXTRACTION FORCE:10~35N
 3000 CYCLES MIN
 5000 CYCLES EXTRACTION FORCE:3~35N
 3. ENVIRONMENTAL:
 OPERATING TEMPERATURE: -55°C+85°C
 4. Contact finish:
 01:Selective Gold Flash
 02:Selective Gold 30"
 03:Selective Gold 50"
 04:Selective Gold 15U"
 05:Selective Gold 30U"

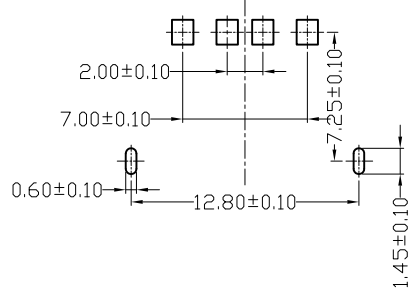

FRONT EDGE OF CONNECTOR
PCB LAYOUT

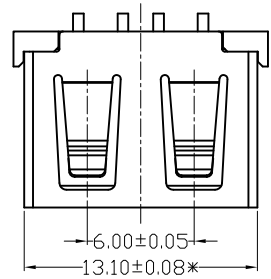
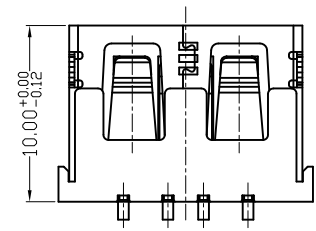
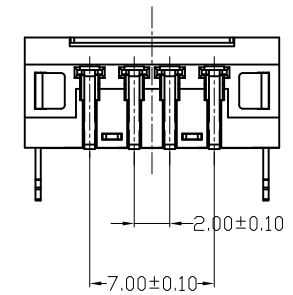
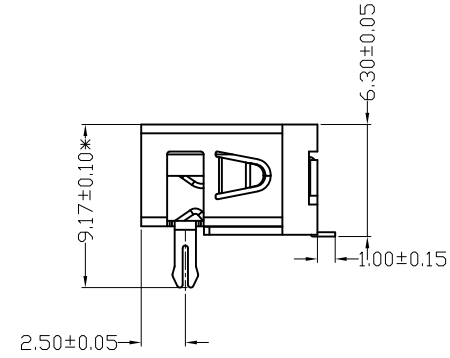
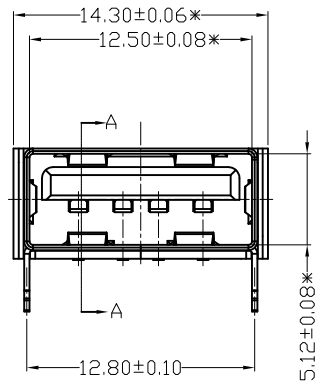

产品图 PRODUCT CHART DWG				单位 UNITS		MM	制图 DRAWING	Z-Y-B	制图料号 PRODUCT PART NO.		
公差一览表 TOLERANCE UNLESS OTHERWISE				比例 SCALE		1:1	审核 CHKD		产品名称 PRODUCT NAME	C42493	
X.	±0.25	X.	±5.°	日期 DATE		2012.06.15	核准 APPD		角法 VIEW		
.X	±0.20	.X	±2.°							版本 VER	AD
.XX	±0.15	.XX	±1.°								
.XXX	±0.10	.XXX	±0.5°								