

MAPX	MODIFICATION	DATE

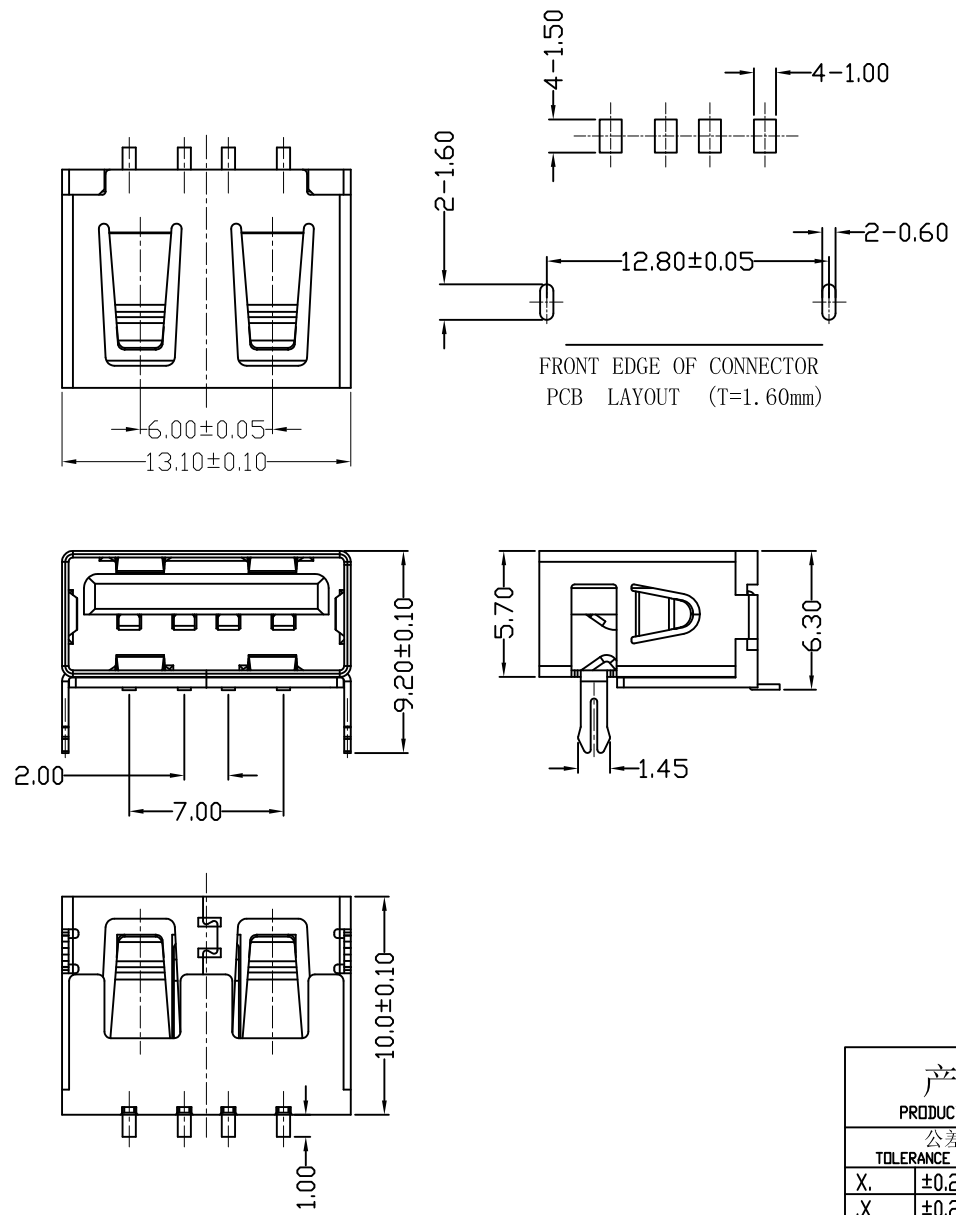

NOTES:

- 1. HOUSING: SEE NOTES,
- TERMINAL: SEE NOTES.
- SHELL: SEE NOTES.

SPECIFICATION:

- 1. ELECTRICAL CHARACTERISTIC:
  - CONTACT RESISTANCE: 30MΩ MAX
  - DIELECTRIC WITHSTANDING VOLTAGE: 500V AC FOR 1MIN
  - INSULATION RESISTANCE: 1000MΩ MIN
- 2. MECHANICAL CHARACTERISTIC:
  - INSERTION FORCE: 35N(3.57KGF) MAX
  - EXTRACTION FORCE: 10~35N(1.02~3.57KGF) MIN
  - DURABILITY: 1500 CYCLES EXTRACTION FORCE:10~35N  
5000 CYCLES MIN
  - 5000 CYCLES EXTRACTION FORCE:3~35N
- 3. ENVIRONMENTAL:
  - OPERATING TEMPERATURE: -55℃+85℃
- 4. Contact finish:
  - 01:Selective Gold Flash
  - 02:Selective Gold 3U"
  - 03:Selective Gold 5U"
  - 04:Selective Gold 15U"
  - 05:Selective Gold 30U"

产品图 PRODUCT CHART DWG										
公差一览表 TOLERANCE UNLESS OTHERWISE				单位 UNITS	MM	制图 DRAWING	Z-Y-B	制图料号 PRODUCT PART NO.		
X.	±0.25	X.	±5.°	比例 SCALE	1:1	审核 CHKD		产品名称 PRODUCT NO.	C42497	
.X	±0.20	.X	±2.°	日期 DATE	2012.10.15	核准 APPD		角法 VIEW		版本 VER
.XX	±0.15	.XX	±1.°							AD
.XXX	±0.10	.XXX	±0.5°							