

MAPX	MODIFICATION	DATE

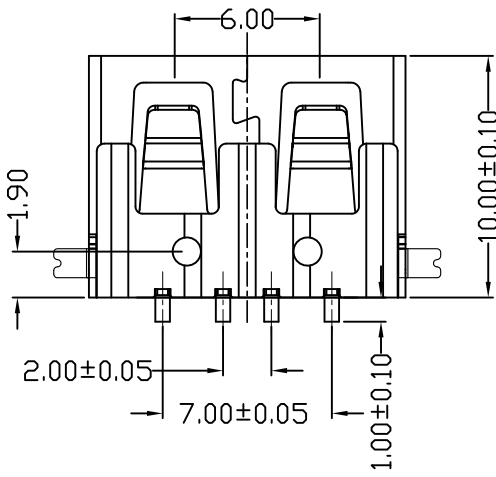

NOTES:
 1.HOUSING: SEE NOTES,
 TERMINAL: SEE NOTES.
 SHELL: SEE NOTES.
 SPECIFICATION:
 1.ELECTRICAL CHARACTERISTIC:
 CONTACT RESISTANCE: 30MΩ MAX
 DIELECTRIC WITHSTANDING VOLTAGE: 500V AC FOR 1MIN
 INSULATION RESISTANCE: 1000MΩ MIN
 2.MECHANICAL CHARACTERISTIC:
 INSERTION FORCE: 35N(3.57KGF) MAX
 EXTRACTION FORCE: 10~35N(1.02~3.57KGF)MIN
 DURABILITY: 1500 CYCLES EXTRACTION FORCE:10~35N
 5000 CYCLES MIN
 5000 CYCLES EXTRACTION FORCE:3~35N
 3.ENVIRONMENTAL:
 OPERATING TEMPERATURE: -55°C+85°C
 4.Contact finish:
 01:Selective Gold Flash
 02:Selective Gold 3U"
 03:Selective Gold 5U"
 04:Selective Gold 15U"
 05:Selective Gold 30U"

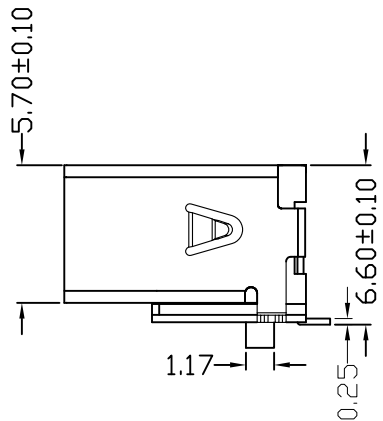
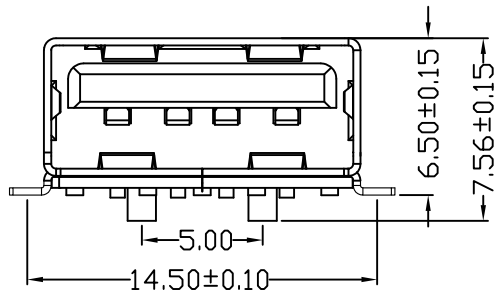
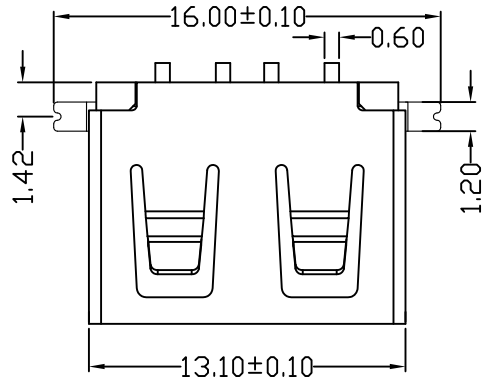
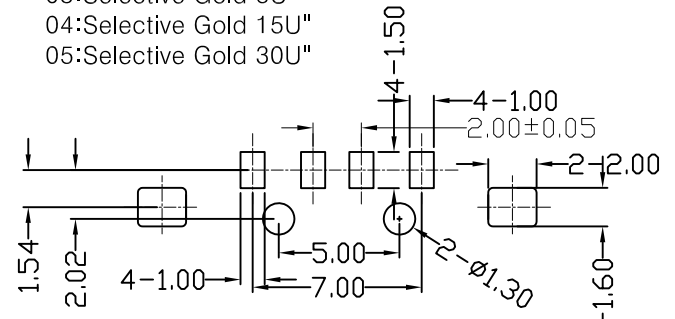

FRONT EDGE OF CONNECTOR
PCB LAYOUT

产品图 PRODUCT CHART DWG 公差一览表 TOLERANCE UNLESS OTHERWISE				单位 UNITS	MM	制图 DRAWING	Z-Y-B	制图料号 PRODUCT PART NO.		
X.	±0.25	X.	±5.°	比例 SCALE	1:1	审核 CHKD		产品名称 PRODUCT NAME	C42527	
.XX	±0.15	.XX	±1.°	日期 DATE	2013.04.24	核准 APPD		角法 VIEW	版本 VER	AD
.XXX	±0.10	.XXX	±0.5°							