

MAPX	MODIFICATION	DATE

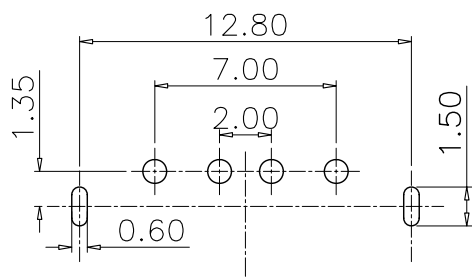

PCB HOLES(THE PATTERN SIDE)  
NOTE:GENERAL TOLERANCE:±0.1mm

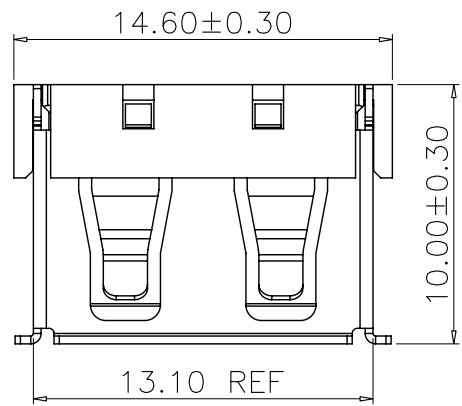
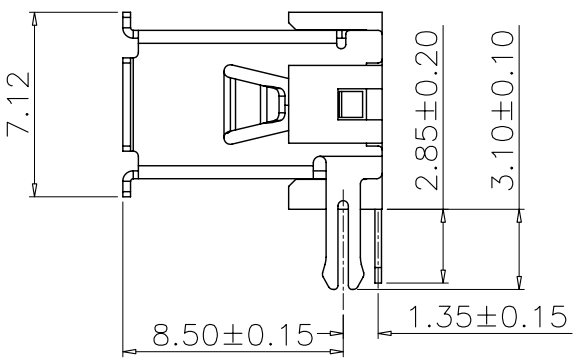
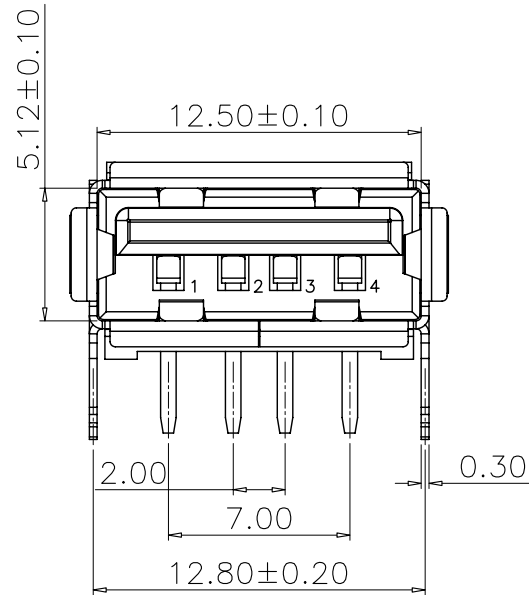

NOTES:

- 1. HOUSING: SEE NOTES,
- TERMINAL: SEE NOTES.
- SHELL: SEE NOTES.

SPECIFICATION:

- 1. ELECTRICAL CHARACTERISTIC:
  - CONTACT RESISTANCE: 30MΩ MAX
  - DIELECTRIC WITHSTANDING VOLTAGE: 500V AC FOR 1MIN
  - INSULATION RESISTANCE: 1000MΩ MIN
- 2. MECHANICAL CHARACTERISTIC:
  - INSERTION FORCE: 35N(3.57KGF) MAX
  - EXTRACTION FORCE: 10~35N(1.02~3.57KGF) MIN
  - DURABILITY: 1500 CYCLES EXTRACTION FORCE:10~35N 5000 CYCLES MIN
  - 5000 CYCLES EXTRACTION FORCE:3~35N
- 3. ENVIRONMENTAL:
  - OPERATING TEMPERATURE: -55°C+85°C
- 4. Contact finish:
  - 01:Selective Gold Flash
  - 02:Selective Gold 3U"
  - 03:Selective Gold 5U"
  - 04:Selective Gold 15U"
  - 05:Selective Gold 30U"

产品图 PRODUCT CHART DWG 公差一览表 TOLERANCE UNLESS OTHERWISE						单位 UNITS	MM	制图 DRAWING	Z-Y-B	制图料号 PRODUCT PART NO.	USB A/F 10.0-B-004		
X	±0.15	X	±5°	.X	±2°	比例 SCALE	1:1	审核 CHKD		产品名称 PRODUCT NO.	USB A/F 10.0 (后两脚有边)		
.XX	±0.05	.XX	±1°	.XXX	±0.5°	日期 DATE	2010.05.06	核准 APPD		角法 VIEW	版本 VER	A0	