

MAPX	MODIFICATION	DATE
------	--------------	------

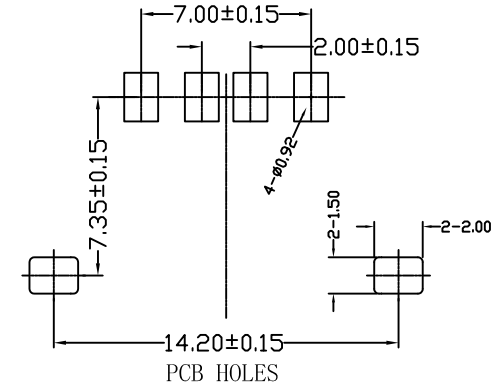
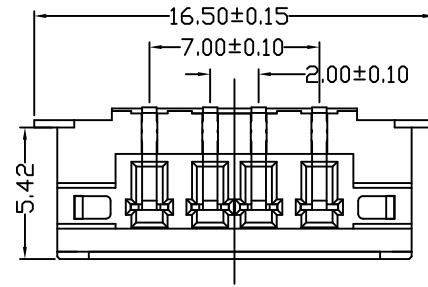
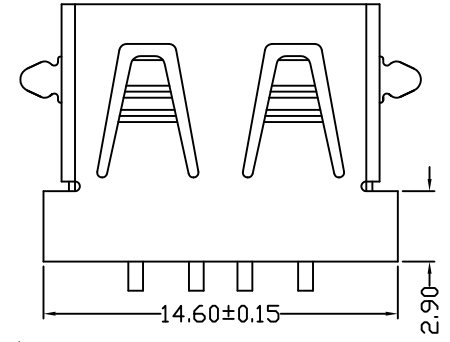
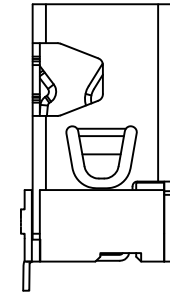
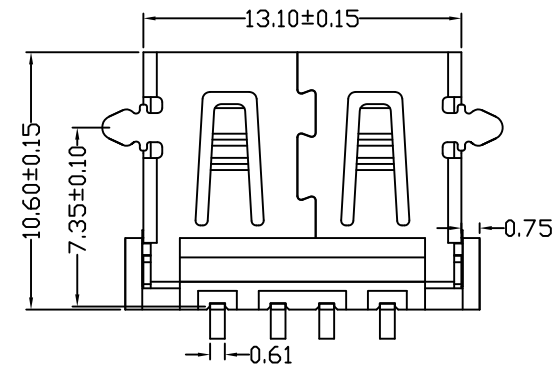
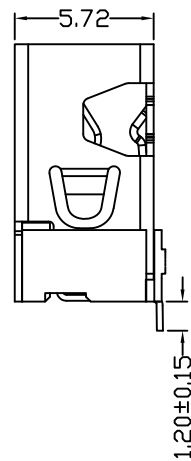
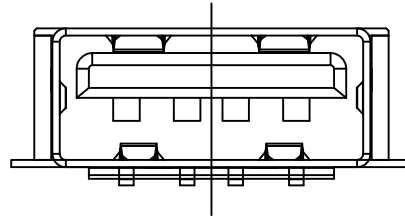

**Specification:**

**1. Electrical Characteristics:**

Dielectric Withstanding Voltage: AC 500V/1MINUTE.  
Insulation Resistance: 1000 MΩ/Min.  
Contact Resistance: 30 mΩ Max.

**2. Mechanical Characteristics:**

INSERTION FORCE: 30N(3.06Kgf) MAX  
EXTRACTION FORCE: 10~30N(1.02~3.06Kgf)  
Durability: 1500cycles. EXTRACTION FORCE: 10~30N(1.02~3.06Kgf)

**3. Material:**

Terminal: Phosphor Bronze, C5191/C2680R-EH T=0.25  
Plating: Gold 0.76 um Min plating over 1.27 um Min Nickel underplate, 2.54 um Min Sn selective plating on solder tail;  
Shell: Bronze, C2680R-H =0.30mm  
Plating: Nickel underplate 2.54 um Min;  
Housing: LCP Black

**4. Environmental:**

Operating Temperature: 0°C to +85°C.

<b>产品图</b> PRODUCT CHART DWG 公差一览表 TOLERANCE UNLESS OTHERWISE				单位 UNITS	MM	制图 DRAWING	Z-Y-B	制图料号 PRODUCT PART NO.		
X.	±0.25	X.	±5.°	比例 SCALE	1:1	审核 CHKD		产品名称 PRODUCT NO.	C42566	
.XX	±0.15	.XX	±1.°	日期 DATE	2014.03.28	核准 APPD		角法 VIEW	版本 VER	AD
.XXX	±0.05	.XXX	±0.5°							