

REV	MODIFICATION	DATE
A0	胶芯变更	2013.12.20

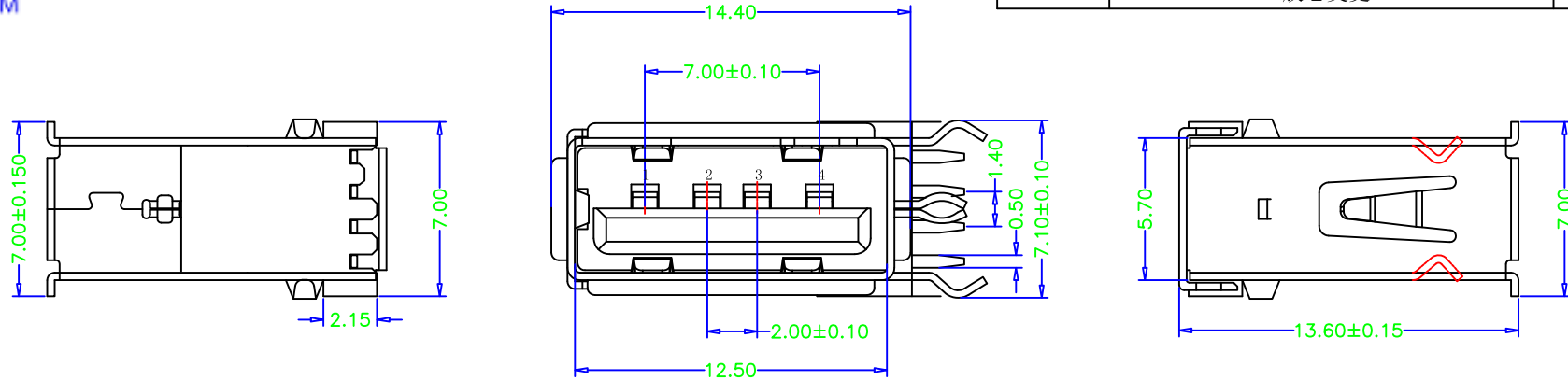

NOTE:

1. Material:

Housing: Thermoplastics (ROHS, HF)

Contact: Phosphor Bronze C5191-EH/C2680-EH, T=0.25mm

Shell: COPPER ALLOY T=0.30mm

2. FINISH:

Contact: 15u" Gold Plated on Contact Area,

80u" Min. Tin Plated on Solder Area

50u" Min. Nickel Underplating Over All.

Shell: 50u" Min. Nickel Underplating Over All.

3. Specification:

3.1: Rating:

Rated voltage 500V AC/DC. Rated current: 2 A Max.

3.2: Electrical:

Insulation Resistance (EIA-364-21):

1000MΩ Min. at 500V/DC for 1Minute.

Contact Resistance (EIA-364-23):

30 mΩ Max. at 20mV Max, 50mA

Dielectric Withstanding Voltage (EIA-364-20):

No discharge, flashover or breakdown at 500V/AC 1Minute

4. Plug extraction force shall be between 1.0kgf and 2.00kgf

5. Contact finish:

01: Selective Gold Flash

02: Selective Gold 1U"

03: Selective Gold 3U"

04: Selective Gold 5U"

05: Selective Gold 15U"

06: Selective Gold 30U"

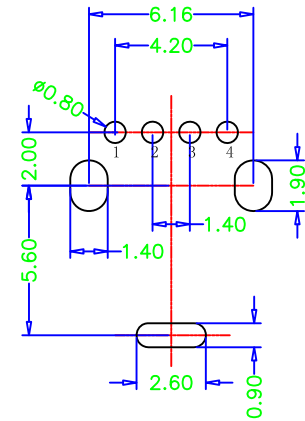
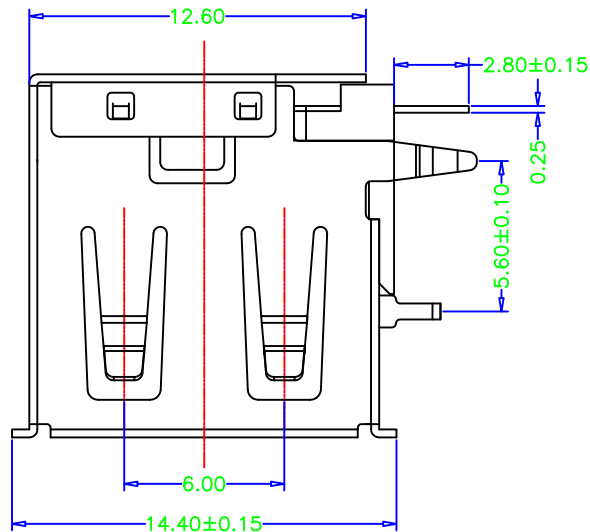

RECOMMENDED PCB LAYOUT
GENERAL TOLERANCES: ±0.05

产品图 PRODUCT CHART DWG 公差一览表 TOLERANCE UNLESS OTHERWISE				单位	MM	制图	Z-Y-B	制图料号	
X	±0.25	X	±5.°	UNITS		审核		产品名称	USB A/F侧立短体4PIN 0型脚有卷边
.X	±0.20	.X	±2.°	SCALE	1:1	核准		PRODUCT NO.	(弯脚 L=13.6)
.XX	±0.15	.XX	±1.°	日期	2013.12.20	APPD		角法	
.XXX	±0.10	.XXX	±0.5°	DATE				版本	A0