



深圳优高电子有限公司

SHENZHEN YKO ELECTRONICS CO.,TLD.

产品规格书

Product specification

产品编码/规格 CUSTOMER PRODUCT SPECIFICATION	YJB-12HG2
名称 TITLE	拨码开关 (CODE SWITCH)
型号 MODEL NO.	SMT SWITCH YAD SERIES
制样 DSGD BY	谢榕
审核 CHKD BY	钟建霞
批准 APPD BY	彭清华
送样印 SENDING PRINT	
承认印 APPD PRINT	
日期 DATE	2012-5-17

公司地址: 中国·深圳光明新区公明西田路荣华工业园三栋三楼

Address: 3F, three floor, Rong Hua Industrial District, Xi Tian Road, Gong
Guang Ming New District, Shen Zhen

Tel: +86-755-61135922 61135811

Fax: +86-755-61135810

http: //www .ykoyko.com

E-mail: ykoyko2010@sina.com

**材料 MATERIALS**

上盖: 工程塑料, 红色、蓝色、黑色

底座: 工程塑料, 黑色

拨键: 工程塑料, 白色

端子: 铜合金, 镀金或者镀银

COVER: Engineering Plastics, Red, Blue, Black

BASE: Engineering Plastics, Black

KEY: Engineering Plastics, White

TERMINAL: Alloy Copper, Plating Gold or Ag

电器性能 ELECTRICAL SPECIFICATIONS

- | | | |
|------------------|----------------------------------------|---------------------------------|
| 1. 接触电阻 (初始值) | Contact resistance (initial): | ≤50mΩ |
| 2. 接触电阻 (测试后) | Contact resistance (after life test): | ≤100mΩ |
| 3. 开关容量 (开关常切换) | Contact rating (Contact rating): | 25mA 24VDC |
| 4. 开关容量 (开关不常切换) | Contact rating (Non-Contact rating): | 100mA |
| 5. 绝缘电阻 | Insulation resistance: | ≥100MΩ.Min. at 500VDC |
| 6. 耐压强度 | Dielectric strength: | 500VAC Min. for 60 seconds. 1mA |
| 7. 极间电容 | Capacitance between adjacent switches: | ≤5PF |

机械特性 MECHANICAL SPECIFICATIONS

- | | | |
|---------|-------------------------------|--------------------------------------------------|
| 1. 操作力 | Operation force: | ≤8N |
| 2. 机械寿命 | Mechanical life: | 2000 operations |
| 3. 使用温度 | Operating Temperature: | -20°C ~ +70°C |
| 4. 储存温度 | Storage Temperature: | -40°C ~ +85°C |
| 5. 可焊性 | Solderability: | After flux 230±5°C for 5±0.5seconds, 95%coverage |
| 6. 耐焊接热 | Resistance to soldering heat: | 260±5°C for 5±1seconds |

焊接

- 在所有操作过程中, 请确保开关在OFF位置
- 波焊: (DIP型) 推荐焊接焊锡温度为250°C, 最多10秒
- 手焊: 使用30W烙铁控制温度在350°C, 焊接时间大约5秒钟

SOLDERING PROCESSES

- Keep all switch contacts in their "OFF" position for all operations
- WAVE SOLDERING: Recommended solder temperature at 250°C max. 10 seconds
- HAND SOLDERING: Use a soldering iron of 30 Watts controlled at 350°C approximately 5 seconds. While applying

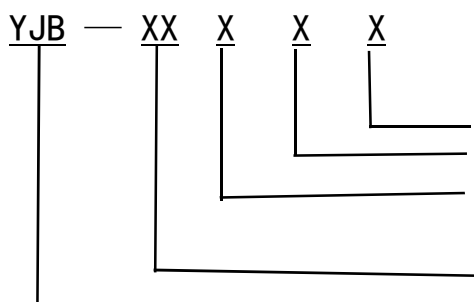
型号命名 PRODUCT NAMING:

1: 手工生产 2: 自动化生产

G: 镀金 A: 镀银 T: 镀锡 G: Gold A: Silver T: Tin

外壳颜色: H为红色 L为蓝色 B为黑色

Cover Color: H:red L:blue B:black

产品位数 Position of Product

YJB系列 YJB Series



产品位数 Product position

01	02	03	04	05	06	07	08	09	10	12
一位	二位	三位	四位	五位	六位	七位	八位	九位	十位	十二位
one	two	three	four	five	six	seven	eight	nine	ten	twelve

外形及装配尺寸 Shape and Assembly size

DIMENSION A (General tolerance: ± 0.3)

POSITIONS	1	2	3	4	5	6	7	8	9	10	12
A	4.0	6.5	9.1	11.6	14.2	16.7	19.2	21.8	24.3	26.9	31.9

YJB DIMENSIONS Unit:mm

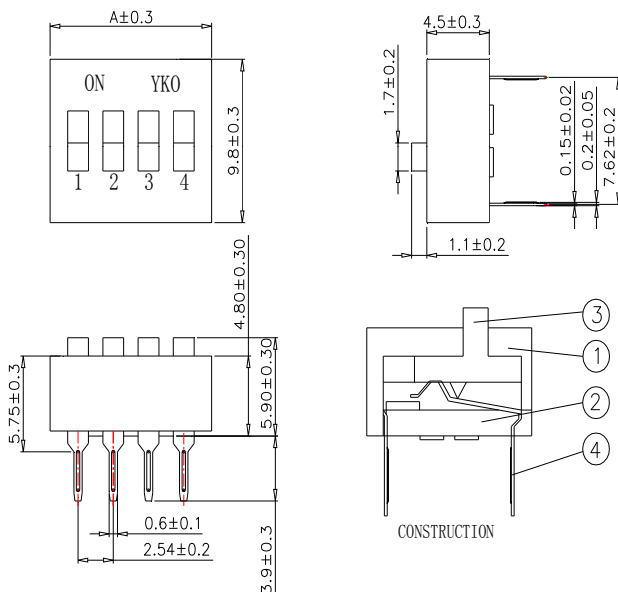

ITEM	DES	MATERIALS	TREATMENT
1	COVER	ENGINEERING PLASTICS	RED, BLUE, BLACK
2	BASE	ENGINEERING PLASTICS	BLACK
3	KEY	ENGINEERING PLASTICS	WHITE
4	TERMINAL	ALLOY COPPER	PLATING GOLD

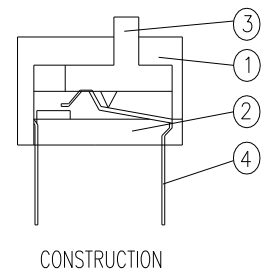
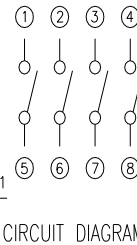
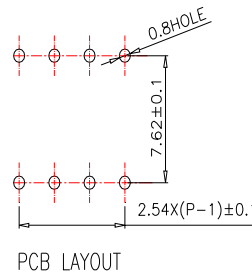
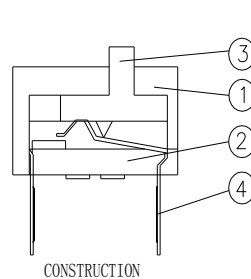

产品包装 Packing

所有拨码产品皆以 IC 管形式包装。

All Code Switches are shipped in standard IC tube

YJB 系列包装资料(Packing of YJB)

系列	开关位数	每管数量	每小箱数量	外包装
SERIES	NO. of POS	PER TUBE	PER BOX	PER BOX
YJB	1	118PCS	11682PCS	
YJB	2	70PCS	6300PCS	
YJB	3	51PCS	4590PCS	
YJB	4	40PCS	3960PCS	
YJB	5	33PCS	3267PCS	6 BOXES
YJB	6	28PCS	2772PCS	55. 5x30. 5x40CM
YJB	7	24PCS	2376PCS	
YJB	8	21PCS	2079PCS	
YJB	9	19PCS	1881PCS	
YJB	10	17PCS	1683PCS	
YJB	12	14PCS	1386PCS	

