

# LM48580 Boomer™ Audio Power Amplifier Series High Efficiency Class H, High Voltage, Haptic Piezo Actuator / Ceramic Speaker Driver

Check for Samples: [LM48580](#)

## FEATURES

- Class H Driver
- Integrated Boost Converter
- Bridge-tied Load Output
- Differential Input
- Three Pin-Programmable Gains
- Low Supply Current
- Minimum External components
- Micro-Power Shutdown
- Thermal Overload Protection
- Available in Space-Saving 12-bump DSBGA package

## APPLICATIONS

- Touch Screen Smart Phones
- Tablet PCs
- Portable Electronic Devices
- MP3 Players

## KEY SPECIFICATIONS

- Output Voltage at  $V_{DD} = 3.6V$ ,  $R_L = 6\mu F + 10\Omega$ ,  $THD+N \leq 1\%$ 
  - $30V_{P-P}$  (Typ)
- Quiescent Power Supply Current at 3.6V
  - 2.7mA (Typ)
- Power Dissipation at  $25V_{P-P}$ 
  - 800mW (Typ)
- Shutdown Current
  - $0.1\mu A$  (Typ)

## DESCRIPTION

The LM48580 is a fully differential, high voltage driver for piezo actuators and ceramic speakers for portable multi-media devices. Part of TI's Powerwise product line, the LM48580's Class H architecture offers significant power savings compared to traditional Class AB amplifiers. The device provides  $30V_{P-P}$  output drive while consuming just 15mW of quiescent power.

The LM48580 is a single supply driver with an integrated boost converter which allows the device to deliver  $30V_{P-P}$  from a single 3.6V supply.

The LM48580 has three pin-programmable gain settings and a low power Shutdown mode that reduces quiescent current consumption to  $0.1\mu A$ . The LM48580 is available in an ultra-small 12-bump DSBGA package (1.46mm x 1.97mm).



Please be aware that an important notice concerning availability, standard warranty, and use in critical applications of Texas Instruments semiconductor products and disclaimers thereto appears at the end of this data sheet.

Boomer is a trademark of Texas Instruments.

All other trademarks are the property of their respective owners.

Typical Application

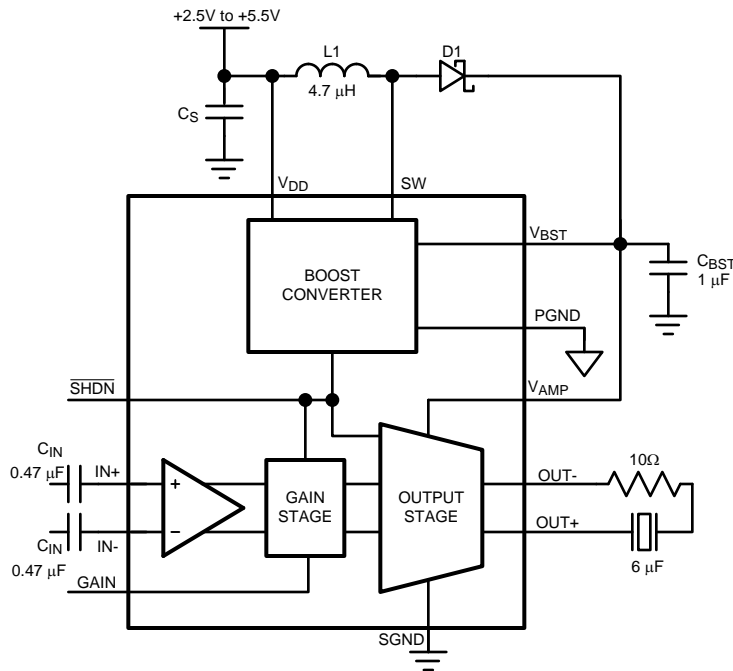

Figure 1. Typical Application Circuit

Connection Diagram

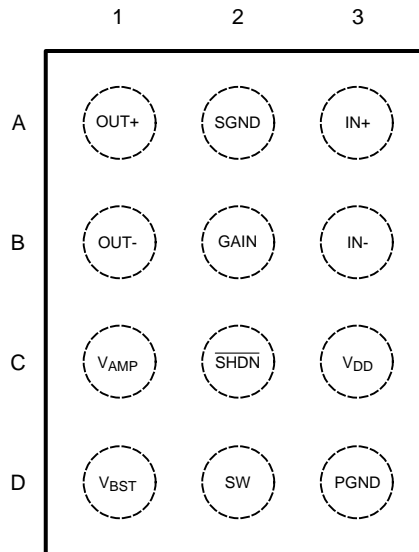
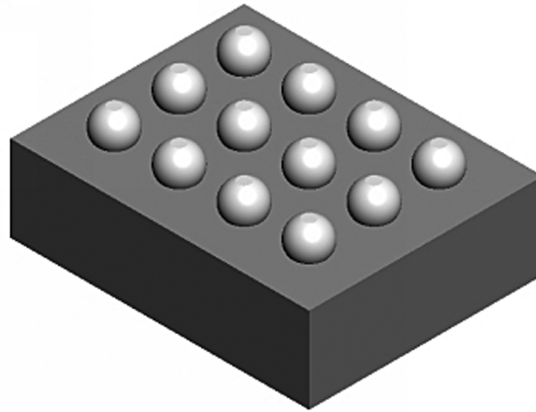

Figure 2. DSBGA Package  
1.46mm x 1.97mm x 0.6mm  
Top View  
See Package Number YZR0012

**Figure 3. YZR0012 Package View (Bumps Up)**
**PIN DESCRIPTIONS**

Bump	Name	Description
A1	OUT+	Amplifier Non-Inverting Output
A2	SGND	Amplifier Ground
A3	IN+	Amplifier Non-Inverting Input
B1	OUT-	Amplifier Inverting Output
B2	GAIN	Gain Select: GAIN = float: $A_V = 18\text{dB}$ GAIN = GND: $A_V = 24\text{dB}$ GAIN = $V_{DD}$ : $A_V = 30\text{dB}$
B3	IN-	Amplifier Inverting Input
C1	$V_{AMP}$	Amplifier Supply Voltage. Connect to $V_{BST}$
C2	$\overline{\text{SHDN}}$	Active Low Shutdown. Drive $\overline{\text{SHDN}}$ low to disable device. Connect $\overline{\text{SHDN}}$ to $V_{DD}$ for normal operation.
C3	$V_{DD}$	Power Supply
D1	$V_{BST}$	Boost Converter Output
D2	SW	Boost Converter Switching Node
D3	PGND	Boost Converter Ground



These devices have limited built-in ESD protection. The leads should be shorted together or the device placed in conductive foam during storage or handling to prevent electrostatic damage to the MOS gates.

### Absolute Maximum Ratings<sup>(1)(2)(3)</sup>

Supply Voltage <sup>(1)</sup>		6V
SW Voltage		25V
VBST Voltage		21V
V <sub>AMP</sub>		17V
Input Voltage		-0.3V to V <sub>DD</sub> + 0.3V
Power Dissipation <sup>(4)</sup>		Internally limited
ESD Rating	Human Body Model <sup>(5)</sup>	2kV
	Machine Model <sup>(6)</sup>	150V
	Charge Device Model <sup>(7)</sup>	750V
Storage Temperature		-65°C to + 150°C
Junction Temperature		150°C
Thermal Resistance	$\theta_{JA}$ (YZR0012)	64 °C/W
Soldering Information	See AN-1112 (SNVA009) "DSBGA Wafer Level Chip Scale Package."	

- (1) "Absolute Maximum Ratings" indicate limits beyond which damage to the device may occur, including inoperability and degradation of device reliability and/or performance. Functional operation of the device and/or non-degradation at the *Absolute Maximum Ratings* or other conditions beyond those indicated in the *Recommended Operating Conditions* is not implied. The *Recommended Operating Conditions* indicate conditions at which the device is functional and the device should not be operated beyond such conditions. All voltages are measured with respect to the ground pin, unless otherwise specified.
- (2) The *Electrical Characteristics* tables list ensured specifications under the listed *Recommended Operating Conditions* except as otherwise modified or specified by the *Electrical Characteristics Conditions* and/or Notes. Typical specifications are estimations only and are not ensured.
- (3) If Military/Aerospace specified devices are required, please contact the Texas Instruments Sales Office/Distributors for availability and specifications.
- (4) The maximum power dissipation must be derated at elevated temperatures and is dictated by T<sub>JMAX</sub>,  $\theta_{JA}$ , and the ambient temperature, T<sub>A</sub>. The maximum allowable power dissipation is P<sub>DMAX</sub> = (T<sub>JMAX</sub> - T<sub>A</sub>) /  $\theta_{JA}$  or the given in *Absolute Maximum Ratings*, whichever is lower.
- (5) Human body model, applicable std. JESD22-A114C.
- (6) Machine model, applicable std. JESD22-A115-A.
- (7) Charge device model, applicable std. JESD22-C101-C.

### Operating Ratings

Temperature Range	T <sub>MIN</sub> ≤ T <sub>A</sub> ≤ T <sub>MAX</sub>	-40°C ≤ T <sub>A</sub> ≤ +85°C
Supply Voltage	V <sub>DD</sub>	2.5V ≤ V <sub>DD</sub> ≤ 5.5V

**Electrical Characteristics  $V_{DD} = 3.6V^{(1)(2)}$** 

The following specifications apply for  $R_L = 6\mu F + 10\Omega$ ,  $C_{BST} = 1\mu F$ ,  $C_{IN} = 0.47\mu F$ ,  $A_V = 24dB$  unless otherwise specified. Limits apply for  $T_A = 25^\circ C$ .

Symbol	Parameter	Conditions	LM48580			Units (Limits)
			Min <sup>(3)</sup>	Typ <sup>(4)</sup>	Max <sup>(3)</sup>	
$V_{DD}$	Supply Voltage Range		2.5		5.5	V
$I_{DD}$	Quiescent Power Supply Current	$V_{IN} = 0V, R_L = \infty$				
		$V_{DD} = 3.6V$		2.7	4	mA
		$V_{DD} = 3V$		3		mA
$P_D$	Power Consumption	$V_{OUT} = 25V_{P-P}, f = 200Hz$				
		$V_{DD} = 3.6V$		800		mW
		$V_{DD} = 3V$		830		mW
$I_{SD}$	Shutdown Current	Shutdown Enabled		0.5	2	$\mu A$
$T_{WU}$	Wake-up Time	From Shutdown	1	1.4	1.6	ms
$V_{OS}$	Differential Output Offset Voltage	$V_{DD} = 3.6V$		63	360	mV
$A_V$	Gain	GAIN = FLOAT	17.5	18	18.5	dB
		GAIN = GND	23.5	24	24.5	dB
		GAIN = $V_{DD}$	29.5	30	30.5	dB
$R_{IN}$	Input Resistance		46	52	58	k $\Omega$
$R_{IN}$	Gain Input Resistance	to GND			575	k $\Omega$
		to $V_{DD}$			131	k $\Omega$
$V_{IN}$	Maximum Input Voltage Range	$A_V = 18dB$			3	$V_{P-P}$
$V_{OUT}$	Output Voltage	$f = 200Hz, THD+N = 1\%$ $V_{DD} = 3.6V$ $V_{DD} = 3V$	25	30.5 30.5		$V_{P-P}$ $V_{P-P}$
		$f = 2kHz, THD+N = 5\%$ $V_{DD} = 3.6V$ $V_{DD} = 3V$		11 8.5		$V_{P-P}$ $V_{P-P}$
THD+N	Total Harmonic Distortion + Noise	$V_{OUT} = 25V_{P-P}, f = 200Hz$		0.16		%
PSRR	Power Supply Rejection Ratio (Figure TBD)	$V_{DD} = 3.6V + 200mV_{P-P}$ sine, Inputs AC GND				
		$f_{RIPPLE} = 217Hz,$ $f_{RIPPLE} = 1kHz$		75 71		dB dB
CMRR	Common Mode Rejection Ratio (Figure TBD)	$V_{CM} = 200mV_{P-P}$ sine				
		$f_{RIPPLE} = 217Hz$ $f_{RIPPLE} = 1kHz$		56 55		dB dB
$f_{SW}$	Boost Converter Switching Frequency			2.1		MHz
$I_{LIMIT}$	Boost Converter Current Limit				1100	mA
$V_{IH}$	Logic High Input Threshold	$\overline{SHDN}$	1.2			V
$V_{IL}$	Logic Low Input Threshold	$\overline{SHDN}$			0.45	V
$I_{IN}$	Input Leakage Current	$\overline{SHDN}$		0.1	1	$\mu A$

- (1) "Absolute Maximum Ratings" indicate limits beyond which damage to the device may occur, including inoperability and degradation of device reliability and/or performance. Functional operation of the device and/or non-degradation at the Absolute Maximum Ratings or other conditions beyond those indicated in the Recommended Operating Conditions is not implied. The Recommended Operating Conditions indicate conditions at which the device is functional and the device should not be operated beyond such conditions. All voltages are measured with respect to the ground pin, unless otherwise specified.
- (2) The Electrical Characteristics tables list ensured specifications under the listed Recommended Operating Conditions except as otherwise modified or specified by the Electrical Characteristics Conditions and/or Notes. Typical specifications are estimations only and are not ensured.
- (3) Datasheet min/max specification limits are specified by design, test, or statistical analysis.
- (4) Typical values represent most likely parametric norms at  $T_A = +25^\circ C$ , and at the Recommended Operation Conditions at the time of product characterization and are not specified.

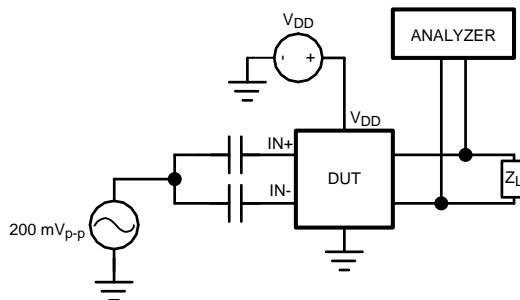

**Figure 4. PSRR Test Circuit**

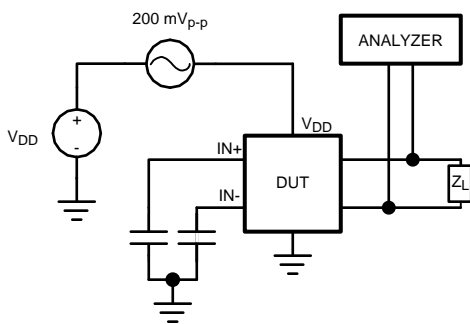

**Figure 5. CMRR Test Circuit**

Typical Performance Characteristics

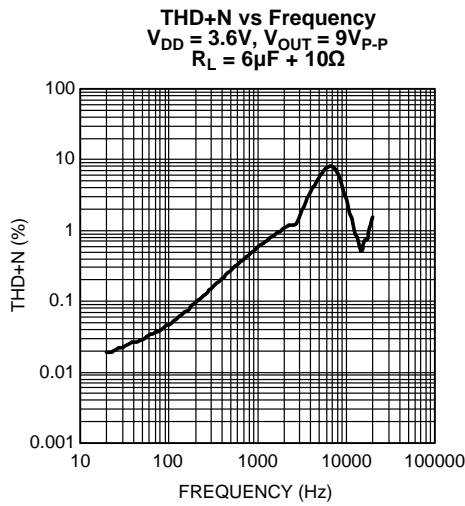

Figure 6.

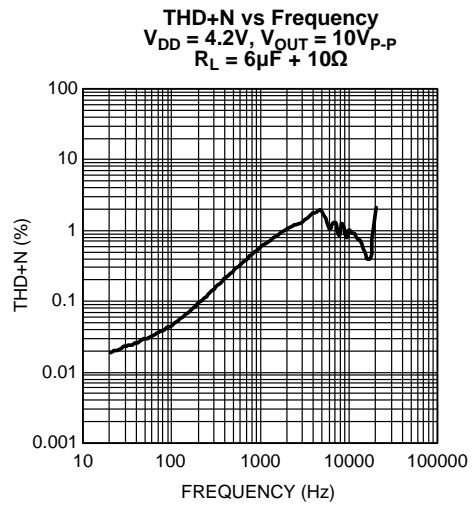

Figure 7.

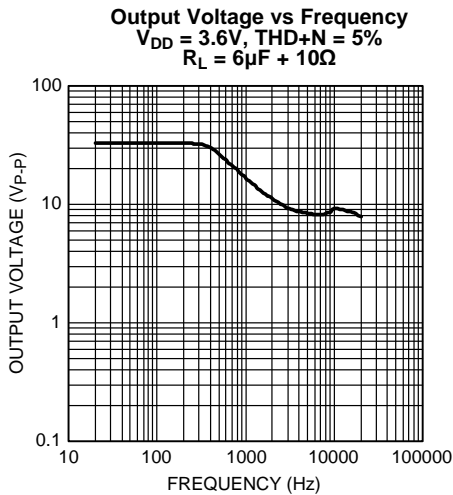

Figure 8.

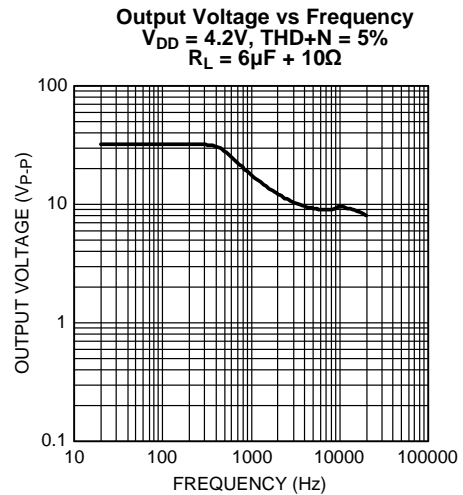

Figure 9.

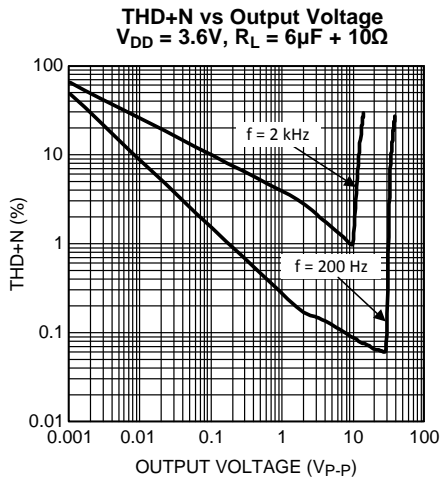

Figure 10.

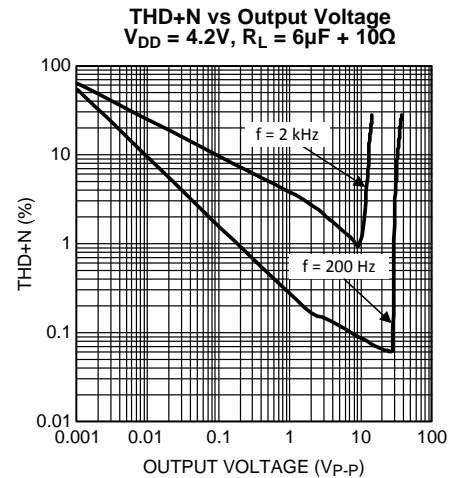

Figure 11.

**Typical Performance Characteristics (continued)**

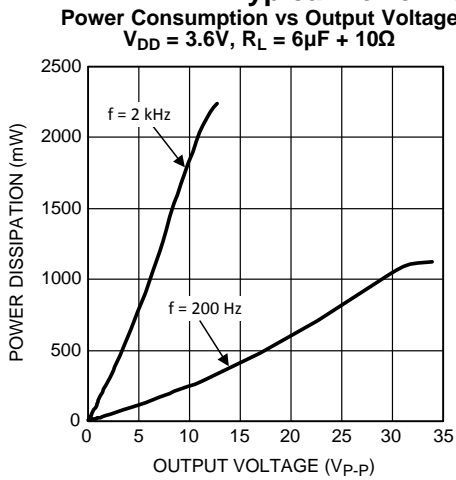

Figure 12.

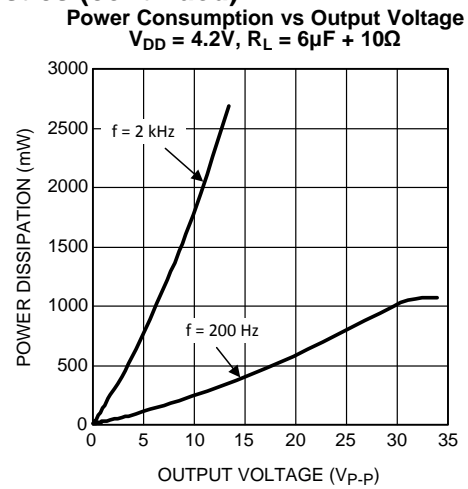

Figure 13.

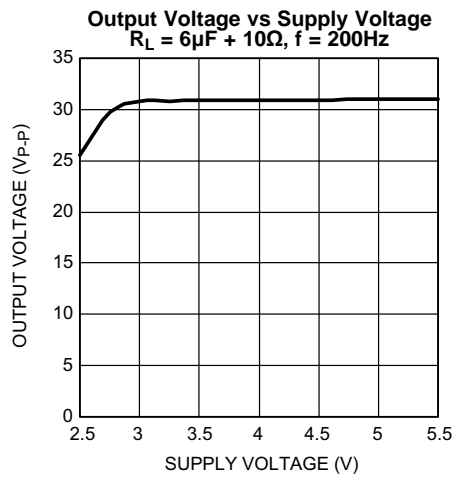

Figure 14.

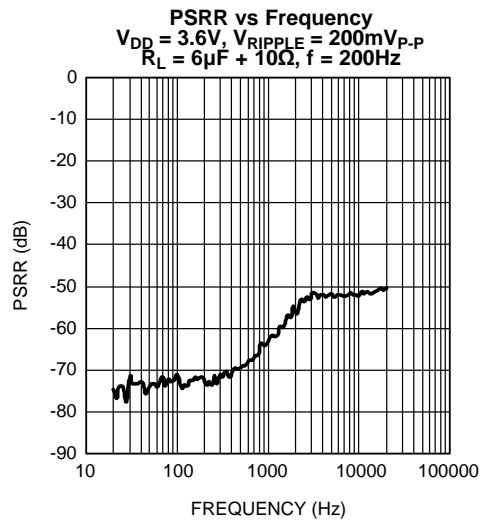

Figure 15.

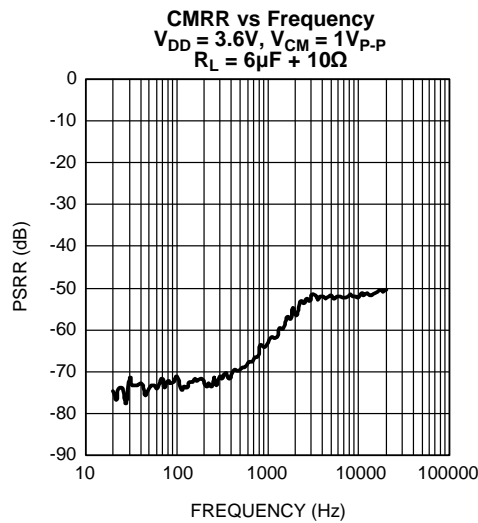

Figure 16.



## APPLICATION INFORMATION

### GENERAL AMPLIFIER FUNCTION

The LM48580 is a fully differential, Class H ceramic element driver for ceramic speakers and haptic actuators. The integrated, high efficiency boost converter dynamically adjusts the amplifier's supply voltage based on the output signal, increasing headroom and improving efficiency compared to a conventional Class AB driver. The fully differential amplifier takes advantage of the increased headroom and bridge-tied load (BTL) architecture, delivering significantly more voltage than a single-ended amplifier.

### CLASS H OPERATION

Class H is a modification of another amplifier class (typically Class B or Class AB) to increase efficiency and reduce power dissipation. To decrease power dissipation, Class H uses a tracking power supply that monitors the output signal and adjusts the supply accordingly. When the amplifier output is below  $3V_{P-P}$ , the nominal boost voltage is 6V. As the amplifier output increases above  $3V_{P-P}$ , the boost voltage tracks the amplifier output as shown in Figure 17. When the amplifier output falls below  $3V_{P-P}$ , the boost converter returns to its nominal output voltage. Power dissipation is greatly reduced compared to conventional Class AB drivers.

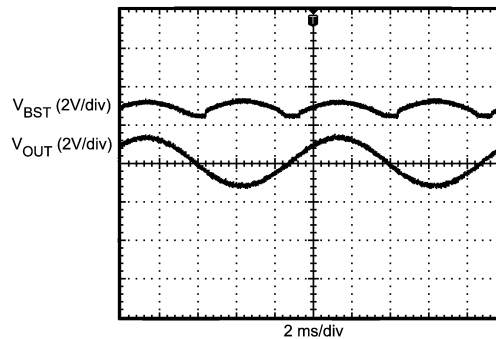

Figure 17. Class H Operation

### PROPERTIES OF PIEZOELECTRIC ELEMENTS

Piezoelectric elements such as ceramic speakers or piezoelectric haptic actuators are capacitive in nature. Due to their capacitive nature, piezoelectric elements appear as low impedance loads at high frequencies (typically above 5kHz). A resistor in series with the piezoelectric element is required to ensure the amplifier does not see a short at high frequencies.

The value of the series resistor depends on the capacitance of the element, the frequency content of the output signal, and the desired frequency response. Higher valued resistors minimize power dissipation at high frequencies, but also impacts the frequency response. This configuration is ideal for use with haptic actuators, where the majority of the signal content is typically below 2kHz. Conversely, lower valued resistors maximize frequency response, while increasing power dissipation at high frequency. This configuration is ideal for ceramic speaker applications, where high frequency audio content needs to be reproduced. Resistor values are typically between  $10\Omega$  and  $20\Omega$ .

### DIFFERENTIAL AMPLIFIER EXPLANATION

The LM48580 features a fully differential amplifier. A differential amplifier amplifies the difference between the two input signals. A major benefit of the fully differential amplifier is the improved common mode rejection ratio (CMRR) over single ended input amplifiers. The increased CMRR of the differential amplifier reduces sensitivity to ground offset related noise injection, especially important in noisy systems.

### THERMAL SHUTDOWN

The LM48580 features thermal shutdown that protects the device during thermal overload conditions. When the junction temperature exceeds  $+160^{\circ}\text{C}$ , the device is disabled. The LM48580 remains disabled until the die temperature falls below the  $+160^{\circ}\text{C}$  and SHDN is toggled.

## GAIN SETTING

The LM48580 features three internally configured gain settings 18, 24, and 30dB. The device gain is selected through a single pin (GAIN). The gain settings are shown in [Table 1](#).

**Table 1. Gain Setting**

Gain	Gain Setting
FLOAT	18dB
GND	24dB
VDD	30dB

## SHUTDOWN FUNCTION

The LM48580 features a low current shutdown mode. Set  $\overline{SD} = \text{GND}$  to disable the amplifier and boost converter and reduce supply current to 0.01 $\mu\text{A}$ .

## SINGLE-ENDED INPUT CONFIGURATION

The LM48580 is compatible with single-ended sources. When configured for single-ended inputs, input capacitors must be used to block and DC component at the input of the device. [Figure 18](#) shows the typical single-ended applications circuit.

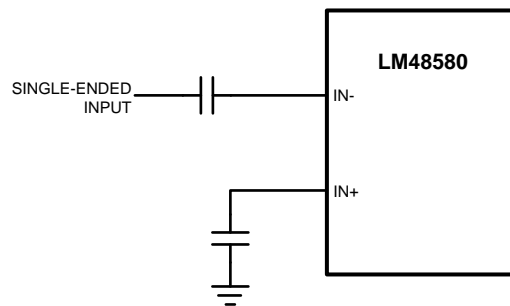

**Figure 18. Single-Ended Configuration**

## PROPER SELECTION OF EXTERNAL COMPONENTS

### Boost Converter Capacitor Selection

The LM48580 boost converter requires three external capacitors for proper operation: a 1 $\mu\text{F}$  supply bypass capacitor, and 1 $\mu\text{F}$  + 100pF output reservoir capacitors. Place the supply bypass capacitor as close to  $V_{\text{DD}}$  as possible. Place the reservoir capacitors as close to  $V_{\text{BST}}$  and  $V_{\text{AMP}}$  as possible. Low ESR surface-mount multi-layer ceramic capacitors with X7R or X5R temperature characteristics are recommended. Select output capacitors with voltage rating of 25V or higher. Tantalum, OS-CON and aluminum electrolytic capacitors are not recommended. See [Demoboard Bill of Materials](#) for suggested capacitor manufacturers.

## BOOST CONVERTER OUTPUT CAPACITOR SELECTION

### Inductor Selection

The LM48580 boost converter is designed for use with a 4.7 $\mu\text{H}$  inductor. [Table 2](#) lists various inductors and their manufacturers. Choose an inductor with a saturation current rating greater than the maximum operating peak current of the LM48580 (> 1A). This ensures that the inductor does not saturate, preventing excess efficiency loss, over heating and possible damage to the inductor. Additionally, choose an inductor with the lowest possible DCR (series resistance) to further minimize efficiency losses.

**Table 2. Recommended Inductors**

MANUFACTURER	PART#	INDUCTANCE/ISAT
Taiyo Yuden	BRL3225T4R7M	4.7 $\mu$ H/1.1A
Coilcraft	LP3015	4.7 $\mu$ H/1.1A

### Diode Selection

Use a Schottky diode as shown in [Figure 1](#). A 20V diode such as the NSR0520V2T1G from On Semiconductor is recommended. The NSR0520V2T1G is designed to handle a maximum average current of 500mA.

### PCB LAYOUT GUIDELINES

Minimize trace impedance of the power, ground and all output traces for optimum performance. Voltage loss due to trace resistance between the LM48580 and the load results in decreased output power and efficiency. Trace resistance between the power supply and ground has the same effect as a poorly regulated supply, increased ripple and reduced peak output power. Use wide traces for power supply inputs and amplifier outputs to minimize losses due to trace resistance, as well as route heat away from the device. Proper grounding improves audio performance, minimizes crosstalk between channels and prevents switching noise from interfering with the audio signal. Use of power and ground planes is recommended.

Place all digital components and route digital signal traces as far as possible from analog components and traces. Do not run digital and analog traces in parallel on the same PCB layer. If digital and analog signal lines must cross either over or under each other, ensure that they cross in a perpendicular fashion.

### Demoboard Bill of Materials

**Table 3. Demoboard Bill of Materials**

DESIGNATOR	QUANTITY	DESCRIPTION
C1	1	10 $\mu$ F $\pm$ 10% 16V
		Tantalum Capacitor (B Case)
		AVX TPSB106K016R0800
C2	1	1 $\mu$ F $\pm$ 10% 16V X5R
		Ceramic Capacitor (603)
		Panasonic ECJ-1VB1C105K Murata GRM188R61C105KA93D
C3	1	1 $\mu$ F $\pm$ 10% 25V X5R
		Ceramic Capacitor (603)
		Panasonic ECJ-1VB1E105K Murata GRM188R61E105KA12D
C4	1	100pF $\pm$ 5% 50V C0G
		Ceramic Capacitor (603)
		Panasonic ECJ-1VC1H101J Murata GRM1885C1H101JA01D
C5, C6	2	4.7 $\mu$ F $\pm$ 10% 10V X5R
		Ceramic Capacitor (603)
		Panasonic ECJ-1VB1A474K Murata GRM188R61A474KA61D
C7	1	0.1 $\mu$ F $\pm$ 10% 50V X7R
		Ceramic Capacitor (603)
		Panasonic ECJ-1VB1H104K Murata GRM188R71H104KA93D
C8	UNSTUFFED	

**Table 3. Demoboard Bill of Materials (continued)**

DESIGNATOR	QUANTITY	DESCRIPTION
D1	1	20V, 500mA
		Schottky Diode (SOD-523)
		ON Semiconductor NSR0520V2T1G
L1	1	4.7 $\mu$ H $\pm$ 20% 1.1A Inductor
		Taiyo Yuden BRL3225T4R7M
JU1, JU2	2	3-Pin Header
LM48580TL	1	LM48580TL (12-Bump DSBGA)

**Demo Board Schematic**

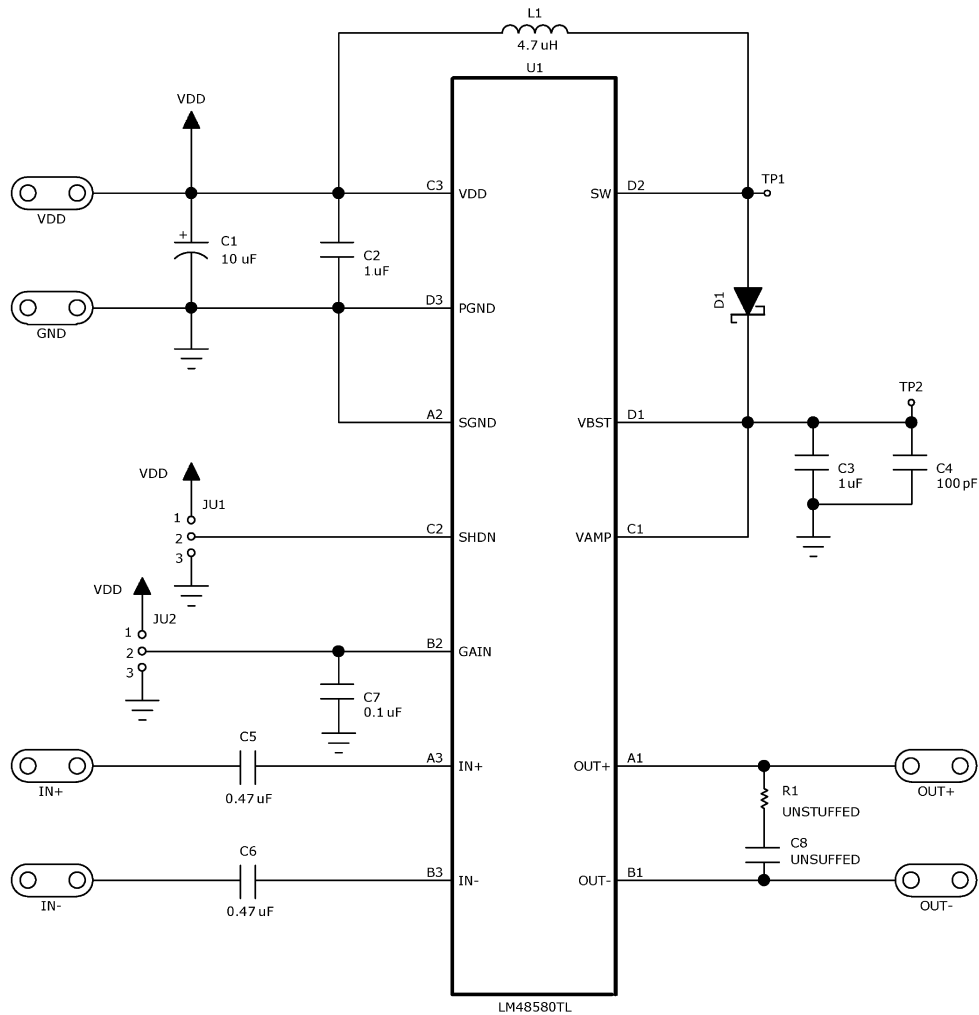

PC Board Layout

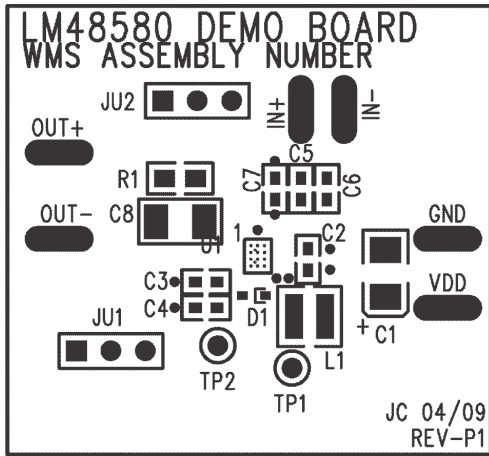

Figure 19. Top Silk Screen

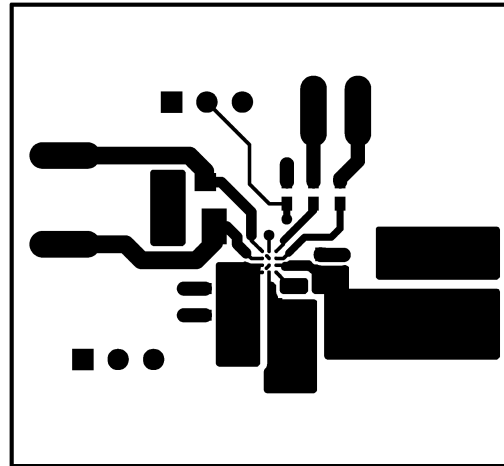

Figure 20. Top Layer

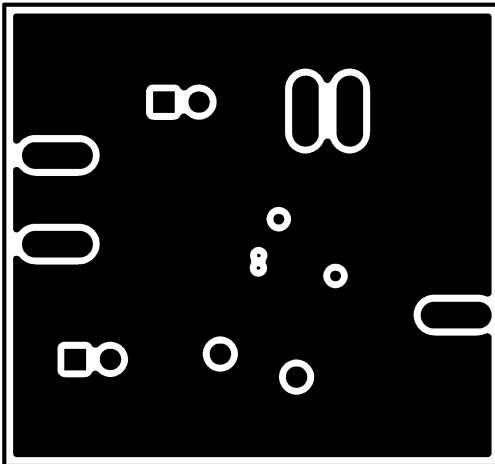

Figure 21. Layer 2

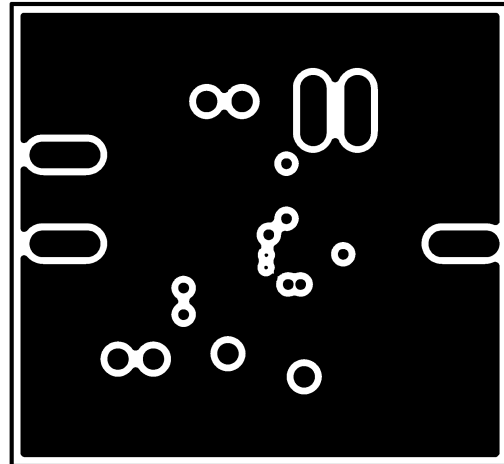

Figure 22. Layer 3

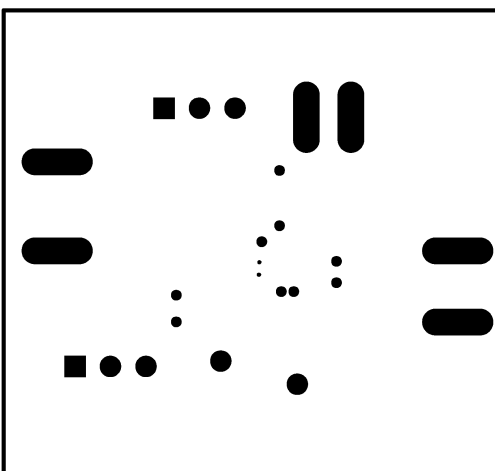

Figure 23. Bottom Silkscreen

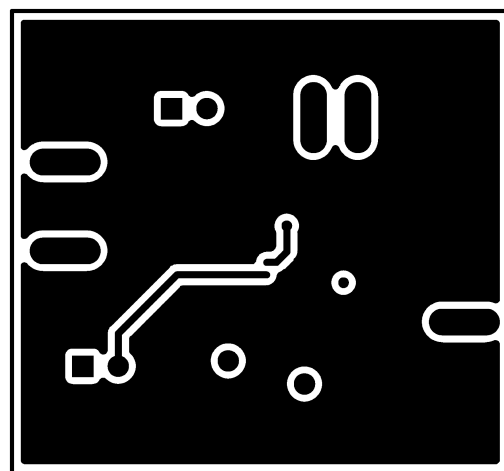

Figure 24. Bottom Layer

**Revision History**

Rev	Date	Description
1.0	02/23/10	Initial released.
A	05/02/2013	Changed layout of National Data Sheet to TI format.

**PACKAGING INFORMATION**

Orderable Device	Status (1)	Package Type	Package Drawing	Pins	Package Qty	Eco Plan (2)	Lead/Ball Finish	MSL Peak Temp (3)	Op Temp (°C)	Top-Side Markings (4)	Samples
LM48580TL/NOPB	ACTIVE	DSBGA	YZR	12	250	Green (RoHS & no Sb/Br)	SNAGCU	Level-1-260C-UNLIM	-40 to 85	GM3	<a href="#">Samples</a>
LM48580TLX/NOPB	ACTIVE	DSBGA	YZR	12	3000	Green (RoHS & no Sb/Br)	SNAGCU	Level-1-260C-UNLIM	-40 to 85	GM3	<a href="#">Samples</a>

(1) The marketing status values are defined as follows:

**ACTIVE:** Product device recommended for new designs.

**LIFEBUY:** TI has announced that the device will be discontinued, and a lifetime-buy period is in effect.

**NRND:** Not recommended for new designs. Device is in production to support existing customers, but TI does not recommend using this part in a new design.

**PREVIEW:** Device has been announced but is not in production. Samples may or may not be available.

**OBSOLETE:** TI has discontinued the production of the device.

(2) Eco Plan - The planned eco-friendly classification: Pb-Free (RoHS), Pb-Free (RoHS Exempt), or Green (RoHS & no Sb/Br) - please check <http://www.ti.com/productcontent> for the latest availability information and additional product content details.

**TBD:** The Pb-Free/Green conversion plan has not been defined.

**Pb-Free (RoHS):** TI's terms "Lead-Free" or "Pb-Free" mean semiconductor products that are compatible with the current RoHS requirements for all 6 substances, including the requirement that lead not exceed 0.1% by weight in homogeneous materials. Where designed to be soldered at high temperatures, TI Pb-Free products are suitable for use in specified lead-free processes.

**Pb-Free (RoHS Exempt):** This component has a RoHS exemption for either 1) lead-based flip-chip solder bumps used between the die and package, or 2) lead-based die adhesive used between the die and leadframe. The component is otherwise considered Pb-Free (RoHS compatible) as defined above.

**Green (RoHS & no Sb/Br):** TI defines "Green" to mean Pb-Free (RoHS compatible), and free of Bromine (Br) and Antimony (Sb) based flame retardants (Br or Sb do not exceed 0.1% by weight in homogeneous material)

(3) MSL, Peak Temp. -- The Moisture Sensitivity Level rating according to the JEDEC industry standard classifications, and peak solder temperature.

(4) Multiple Top-Side Markings will be inside parentheses. Only one Top-Side Marking contained in parentheses and separated by a "~" will appear on a device. If a line is indented then it is a continuation of the previous line and the two combined represent the entire Top-Side Marking for that device.

**Important Information and Disclaimer:** The information provided on this page represents TI's knowledge and belief as of the date that it is provided. TI bases its knowledge and belief on information provided by third parties, and makes no representation or warranty as to the accuracy of such information. Efforts are underway to better integrate information from third parties. TI has taken and continues to take reasonable steps to provide representative and accurate information but may not have conducted destructive testing or chemical analysis on incoming materials and chemicals. TI and TI suppliers consider certain information to be proprietary, and thus CAS numbers and other limited information may not be available for release.

In no event shall TI's liability arising out of such information exceed the total purchase price of the TI part(s) at issue in this document sold by TI to Customer on an annual basis.

## TAPE AND REEL INFORMATION



### QUADRANT ASSIGNMENTS FOR PIN 1 ORIENTATION IN TAPE



\*All dimensions are nominal

Device	Package Type	Package Drawing	Pins	SPQ	Reel Diameter (mm)	Reel Width W1 (mm)	A0 (mm)	B0 (mm)	K0 (mm)	P1 (mm)	W (mm)	Pin1 Quadrant
LM48580TL/NOPB	DSBGA	YZR	12	250	178.0	8.4	1.68	2.13	0.76	4.0	8.0	Q1
LM48580TLX/NOPB	DSBGA	YZR	12	3000	178.0	8.4	1.68	2.13	0.76	4.0	8.0	Q1



**TAPE AND REEL BOX DIMENSIONS**



\*All dimensions are nominal

Device	Package Type	Package Drawing	Pins	SPQ	Length (mm)	Width (mm)	Height (mm)
LM48580TL/NOPB	DSBGA	YZR	12	250	210.0	185.0	35.0
LM48580TLX/NOPB	DSBGA	YZR	12	3000	210.0	185.0	35.0



## IMPORTANT NOTICE

Texas Instruments Incorporated (TI) reserves the right to make corrections, enhancements, improvements and other changes to its semiconductor products and services per JESD46, latest issue, and to discontinue any product or service per JESD48, latest issue. Buyers should obtain the latest relevant information before placing orders and should verify that such information is current and complete.

TI's published terms of sale for semiconductor products (<http://www.ti.com/sc/docs/stdterms.htm>) apply to the sale of packaged integrated circuit products that TI has qualified and released to market. Additional terms may apply to the use or sale of other types of TI products and services.

Reproduction of significant portions of TI information in TI data sheets is permissible only if reproduction is without alteration and is accompanied by all associated warranties, conditions, limitations, and notices. TI is not responsible or liable for such reproduced documentation. Information of third parties may be subject to additional restrictions. Resale of TI products or services with statements different from or beyond the parameters stated by TI for that product or service voids all express and any implied warranties for the associated TI product or service and is an unfair and deceptive business practice. TI is not responsible or liable for any such statements.

Buyers and others who are developing systems that incorporate TI products (collectively, "Designers") understand and agree that Designers remain responsible for using their independent analysis, evaluation and judgment in designing their applications and that Designers have full and exclusive responsibility to assure the safety of Designers' applications and compliance of their applications (and of all TI products used in or for Designers' applications) with all applicable regulations, laws and other applicable requirements. Designer represents that, with respect to their applications, Designer has all the necessary expertise to create and implement safeguards that (1) anticipate dangerous consequences of failures, (2) monitor failures and their consequences, and (3) lessen the likelihood of failures that might cause harm and take appropriate actions. Designer agrees that prior to using or distributing any applications that include TI products, Designer will thoroughly test such applications and the functionality of such TI products as used in such applications.

TI's provision of technical, application or other design advice, quality characterization, reliability data or other services or information, including, but not limited to, reference designs and materials relating to evaluation modules, (collectively, "TI Resources") are intended to assist designers who are developing applications that incorporate TI products; by downloading, accessing or using TI Resources in any way, Designer (individually or, if Designer is acting on behalf of a company, Designer's company) agrees to use any particular TI Resource solely for this purpose and subject to the terms of this Notice.

TI's provision of TI Resources does not expand or otherwise alter TI's applicable published warranties or warranty disclaimers for TI products, and no additional obligations or liabilities arise from TI providing such TI Resources. TI reserves the right to make corrections, enhancements, improvements and other changes to its TI Resources. TI has not conducted any testing other than that specifically described in the published documentation for a particular TI Resource.

Designer is authorized to use, copy and modify any individual TI Resource only in connection with the development of applications that include the TI product(s) identified in such TI Resource. NO OTHER LICENSE, EXPRESS OR IMPLIED, BY ESTOPPEL OR OTHERWISE TO ANY OTHER TI INTELLECTUAL PROPERTY RIGHT, AND NO LICENSE TO ANY TECHNOLOGY OR INTELLECTUAL PROPERTY RIGHT OF TI OR ANY THIRD PARTY IS GRANTED HEREIN, including but not limited to any patent right, copyright, mask work right, or other intellectual property right relating to any combination, machine, or process in which TI products or services are used. Information regarding or referencing third-party products or services does not constitute a license to use such products or services, or a warranty or endorsement thereof. Use of TI Resources may require a license from a third party under the patents or other intellectual property of the third party, or a license from TI under the patents or other intellectual property of TI.

TI RESOURCES ARE PROVIDED "AS IS" AND WITH ALL FAULTS. TI DISCLAIMS ALL OTHER WARRANTIES OR REPRESENTATIONS, EXPRESS OR IMPLIED, REGARDING RESOURCES OR USE THEREOF, INCLUDING BUT NOT LIMITED TO ACCURACY OR COMPLETENESS, TITLE, ANY EPIDEMIC FAILURE WARRANTY AND ANY IMPLIED WARRANTIES OF MERCHANTABILITY, FITNESS FOR A PARTICULAR PURPOSE, AND NON-INFRINGEMENT OF ANY THIRD PARTY INTELLECTUAL PROPERTY RIGHTS. TI SHALL NOT BE LIABLE FOR AND SHALL NOT DEFEND OR INDEMNIFY DESIGNER AGAINST ANY CLAIM, INCLUDING BUT NOT LIMITED TO ANY INFRINGEMENT CLAIM THAT RELATES TO OR IS BASED ON ANY COMBINATION OF PRODUCTS EVEN IF DESCRIBED IN TI RESOURCES OR OTHERWISE. IN NO EVENT SHALL TI BE LIABLE FOR ANY ACTUAL, DIRECT, SPECIAL, COLLATERAL, INDIRECT, PUNITIVE, INCIDENTAL, CONSEQUENTIAL OR EXEMPLARY DAMAGES IN CONNECTION WITH OR ARISING OUT OF TI RESOURCES OR USE THEREOF, AND REGARDLESS OF WHETHER TI HAS BEEN ADVISED OF THE POSSIBILITY OF SUCH DAMAGES.

Unless TI has explicitly designated an individual product as meeting the requirements of a particular industry standard (e.g., ISO/TS 16949 and ISO 26262), TI is not responsible for any failure to meet such industry standard requirements.

Where TI specifically promotes products as facilitating functional safety or as compliant with industry functional safety standards, such products are intended to help enable customers to design and create their own applications that meet applicable functional safety standards and requirements. Using products in an application does not by itself establish any safety features in the application. Designers must ensure compliance with safety-related requirements and standards applicable to their applications. Designer may not use any TI products in life-critical medical equipment unless authorized officers of the parties have executed a special contract specifically governing such use. Life-critical medical equipment is medical equipment where failure of such equipment would cause serious bodily injury or death (e.g., life support, pacemakers, defibrillators, heart pumps, neurostimulators, and implantables). Such equipment includes, without limitation, all medical devices identified by the U.S. Food and Drug Administration as Class III devices and equivalent classifications outside the U.S.

TI may expressly designate certain products as completing a particular qualification (e.g., Q100, Military Grade, or Enhanced Product). Designers agree that it has the necessary expertise to select the product with the appropriate qualification designation for their applications and that proper product selection is at Designers' own risk. Designers are solely responsible for compliance with all legal and regulatory requirements in connection with such selection.

Designer will fully indemnify TI and its representatives against any damages, costs, losses, and/or liabilities arising out of Designer's non-compliance with the terms and provisions of this Notice.