



# SY5882

## Single Stage Flyback and PFC Controller with Primary Side Control for LED Lighting and Multiple Dimming Mode Option *Preliminary Specification*

### General Description

The SY5882 is a single stage Flyback and PFC controller targeting at LED Dimming applications, which can achieve up to 5% dimming level and high precision for all loading range. It is a primary side controller without applying any secondary feedback circuit for low cost, and drives the converter in the quasi-resonant mode to achieve higher efficiency. It keeps the converter in constant on time operation to achieve high power factor.

### Ordering Information

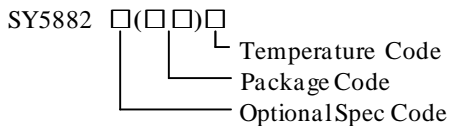

Ordering Number	Package type	Note
SY5882FAC	SO8	----

### Features

- 5.5%~100% Dimming Range.
- CV mode for Bias supply at <5% Dimming Signal.
- Primary side control eliminates the opto-coupler.
- Valley turn-on of the primary MOSFET to achieve low switching losses
- 0.3V primary current sense reference voltage leads to a lower sense resistance thus a lower conduction loss.
- Internal high current MOSFET driver: 0.19A sourcing and 0.63A sinking
- Low start up current: 34μA typical
- Reliable short LED and Open LED protection
- Power factor>0.90 with single-stage conversion.(Analog dimming only)
- Compact package: SO8

### Applications

- LED Dimming
- 

### Typical Applications

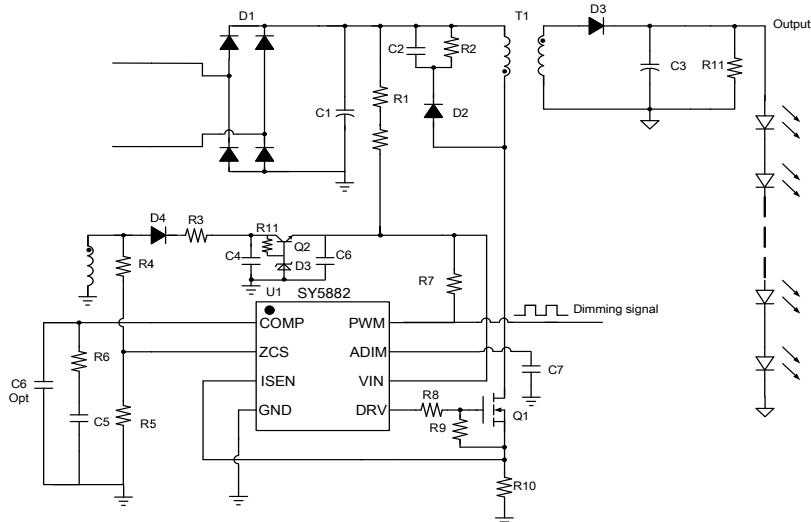
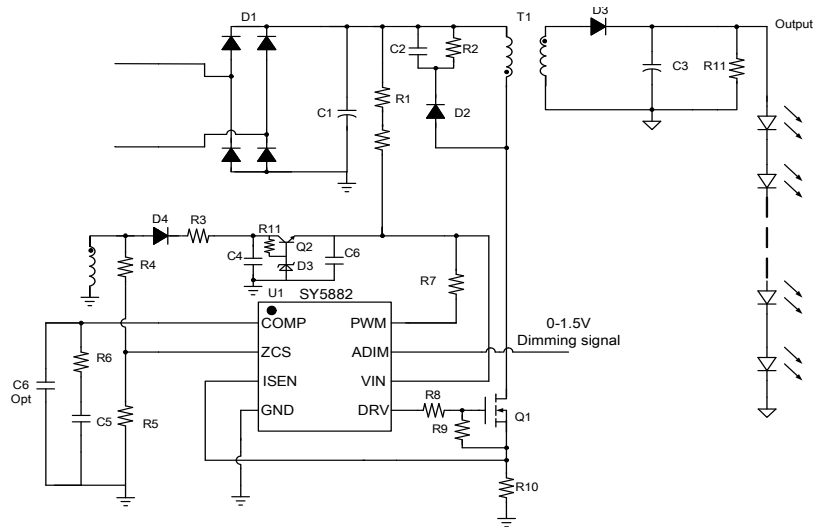
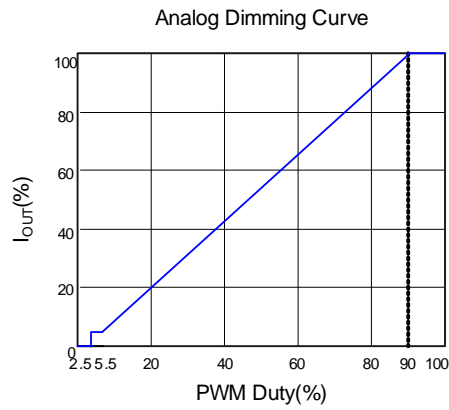

Figure.1a Analog output with PWM dimming signal



**Figure.1b Analog output with 0-1.5V dimming signal**

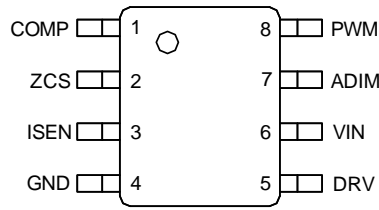

**Figure.1c Dimming curve of Analog dimming**

**Pinout** (top view)

**Top Mark:** BCI xyz (device code: BCI, x=year code, y=week code, z=lot number code)

Pin Name	Pin number	Pin Description
COMP	1	Loop compensation pin. Connect a RC network across this pin and ground to stabilize the control loop.
ZCS	2	Inductor current zero-crossing detection pin. This pin receives the auxiliary winding voltage by a resistor divider and detects the inductor current zero crossing point. This pin also provides over voltage protection, line regulation modification function and CV detection simultaneously. If the voltage on this pin is above $V_{ZCS,OV}$ , the IC would enter over voltage protection mode. Good line regulation can be achieved by adjusting the upper resistor of the divider.
ISEN	3	Current sense pin. Connect this pin to the source of the primary switch. Connect the sense resistor across the source of the primary switch and the GND pin. (current sense resistor $R_S$ : $R_S = k \frac{V_{REF} \times N_{PS}}{I_{OUT}}$ , $k=0.167$ )
GND	4	Ground pin
DRV	5	Gate driver pin. Connect this pin to the gate of primary MOSFET.
VIN	6	Power supply pin. This pin also provides output over voltage protection along with ZCS pin.
ADIM	7	Bypass this pin to GND with enough capacitance to hold on internal voltage reference.
PWM	8	PWM dimming input pin, this pin detects the PWM dimming signal

**Absolute Maximum Ratings** (Note 1)

VIN, DRV	-----	-0.3V~25V
Supply current I <sub>VIN</sub>	-----	7mA
ZCS, PWM	-----	-0.3V~23V
ADIM	-----	-0.3V~15V
I <sub>SEN</sub> , COMP	-----	-0.3~ 3.6V
Power Dissipation, @ T <sub>A</sub> = 25°C SO8	-----	1.1W
Package Thermal Resistance (Note 2)		
SO8, θ <sub>JA</sub>	-----	88°C/W
SO8, θ <sub>JC</sub>	-----	45°C/W
Junction Temperature Range	-----	-40°C to 150°C
Lead Temperature (Soldering, 10 sec.)	-----	260°C
Storage Temperature Range	-----	-65°C to 150°C

**Recommended Operating Conditions** (Note 3)

VIN, DRV	-----	8.5V~20V
----------	-------	----------

**Block Diagram**

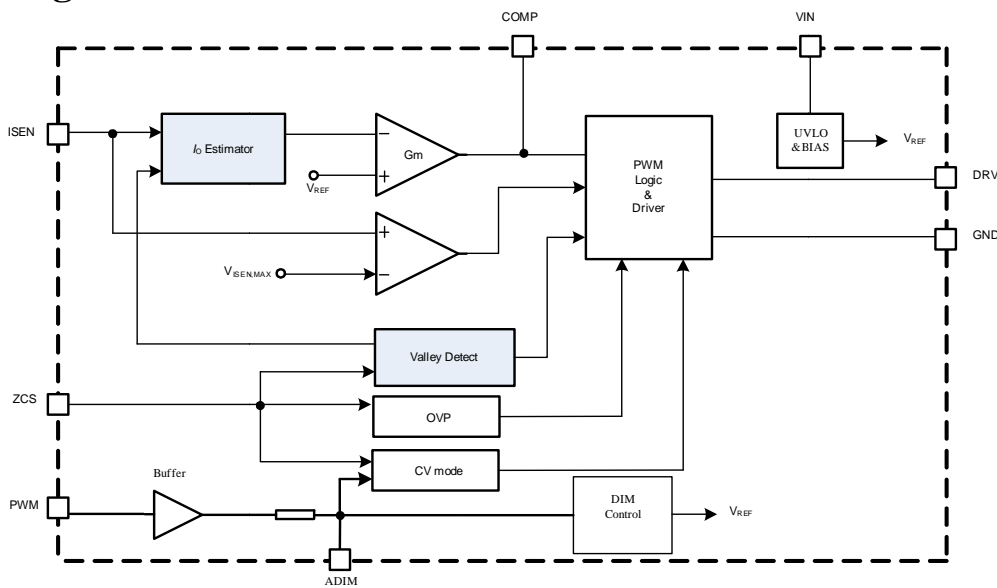

**Figure.3 Block Diagram**



**Electrical Characteristics**

( $V_{IN} = 12V$  (Note 3),  $T_A = 25^{\circ}C$  unless otherwise specified)

Parameter	Symbol	Test Conditions	Min	Typ	Max	Unit
<b>Power Supply Section</b>						
Input voltage range	$V_{VIN}$		8.5		22	V
VIN turn-on threshold	$V_{VIN,ON}$		19	20	22	V
VIN turn-off threshold	$V_{VIN,OFF}$		7.5	8.0	8.5	V
VIN OVP voltage	$V_{VIN,OVP}$		22	23	24	V
Start up Current	$I_{ST}$	$V_{VIN} < V_{VIN,OFF}$		34		$\mu A$
Operating Current	$I_{VIN}$	$C_L = 100pF, f = 15kHz$		1		mA
Shunt current in OVP mode	$I_{VIN,OVP}$	$V_{VIN} > V_{VIN,OVP}$		7		mA
<b>Error Amplifier Section</b>						
Internal reference voltage	$V_{REF}$		0.294	0.3	0.306	V
<b>Current Sense Section</b>						
Current limit reference voltage	$V_{ISEN,MAX}$			0.45		V
<b>ZCS pin Section</b>						
ZCS pin OVP voltage threshold	$V_{ZCS,OVP}$			1.5		V
<b>COMP Section</b>						
Pre-charge value	$V_{COMP,PRE}$			0.9		V
<b>Gate Driver Section</b>						
Gate driver voltage	$V_{Gate}$			$V_{VIN}$		V
Maximum source current	$I_{SOURCE}$			0.19		A
Minimum sink current	$I_{SINK}$			0.63		A
Max ON Time	$T_{ON,MAX}$	$V_{COMP} = 1.5V$		16		$\mu s$
Min ON Time	$T_{ON,MIN}$			500		ns
Max OFF Time	$T_{OFF,MAX}$			120		$\mu s$
Min OFF Time	$T_{OFF,MIN}$			1.5		$\mu s$
Maximum switching frequency	$f_{MAX}$			120		kHz
<b>ADIM function Section</b>						
ADIM Enable ON	$V_{ADIM,ON}$			0.075		V
ADIM EnableOFF	$V_{ADIM,OFF}$			0.037		V
Analog dimming effective range	$V_{ADIM,Dimming}$		0.075		1.35	V
<b>Thermal Section</b>						
Thermal Fold back Temperature	$T_{FB}$			150		$^{\circ}C$
Thermal shut down Temperature	$T_{SD}$			160		$^{\circ}C$
<b>PWM function Section</b>						
PWM ON current	$V_{PWM,ON}$			1.5		V
PWM OFF current	$V_{PWM,OFF}$			$V_{PWM,ON} - 0.1$		V

**Note 1:** Stresses beyond the “Absolute Maximum Ratings” may cause permanent damage to the device. These are stress ratings only. Functional operation of the device at these or any other conditions beyond those indicated in the operational sections of the specification is not implied. Exposure to absolute maximum rating conditions for extended periods may affect device reliability.

**Note 2:**  $\Theta_{JA}$  is measured in the natural convection at  $T_A = 25^{\circ}C$  on a low effective single layer thermal conductivity test board of JEDEC 51-3 thermal measurement standard. Test condition: Device mounted on 2” x 2” FR-4 substrate PCB, 2oz copper, with minimum recommended pad on top layer and thermal vias to bottom layer ground plane.

**Note 3:** Increase VIN pin voltage gradually higher than  $V_{VIN,ON}$  voltage then turn down to 12V.

**SO8 Package Outline & PCB Layout Design**

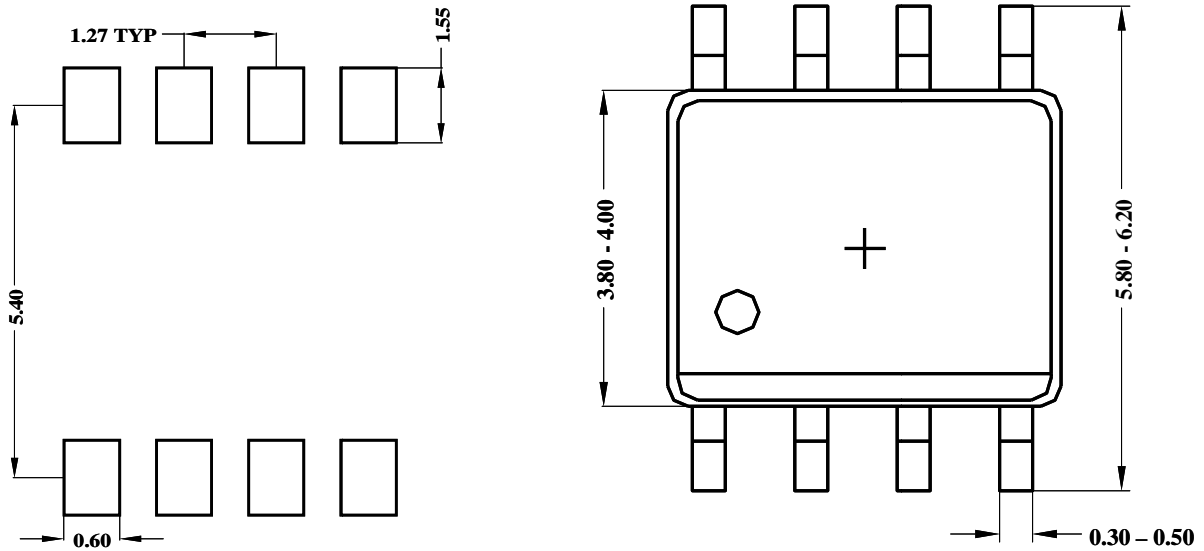

**Recommended Pad Layout**

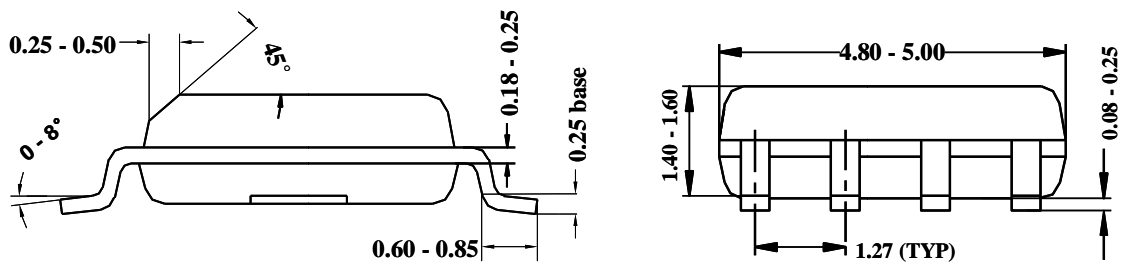

**Notes: All dimensions are in millimeters.  
All dimensions don't include mold flash & metal burr.**