



AOD417

P-Channel Enhancement Mode Field Effect Transistor

General Description

The AOD417 uses advanced trench technology to provide excellent $R_{DS(ON)}$, low gate charge and low gate resistance. With the excellent thermal resistance of the DPAK package, this device is well suited for high current load applications.

- RoHS Compliant
- Halogen Free*

Features

- V_{DS} (V) = -30V
- I_D = -25A (V_{GS} = -10V)
- $R_{DS(ON)}$ < 34m Ω (V_{GS} = -10V)
- $R_{DS(ON)}$ < 55m Ω (V_{GS} = -4.5V)

100% UIS Tested!
100% Rg Tested!

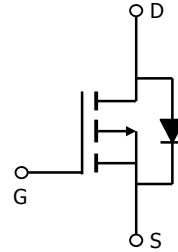
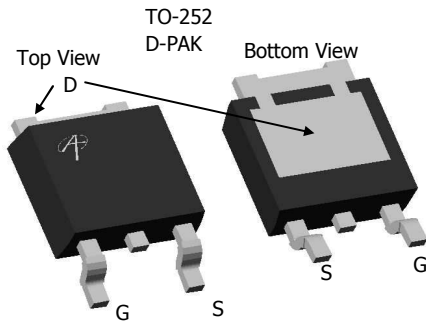

Absolute Maximum Ratings $T_A=25^\circ\text{C}$ unless otherwise noted

Parameter	Symbol	Maximum	Units
Drain-Source Voltage	V_{DS}	-30	V
Gate-Source Voltage	V_{GS}	± 20	V
Continuous Drain Current ^{B,G}	$T_A=25^\circ\text{C}$ ^G	-25	A
		$T_A=100^\circ\text{C}$	
Pulsed Drain Current ^C	I_{DM}	-60	
Avalanche Current ^C	I_{AR}	-14	A
Repetitive avalanche energy $L=0.3\text{mH}$ ^C	E_{AR}	30	mJ
Power Dissipation ^B	P_D	$T_C=25^\circ\text{C}$	50
		$T_C=100^\circ\text{C}$	25
Power Dissipation ^A	P_{DSM}	$T_A=25^\circ\text{C}$	2.5
		$T_A=70^\circ\text{C}$	1.6
Junction and Storage Temperature Range	T_J, T_{STG}	-55 to 175	$^\circ\text{C}$

Thermal Characteristics

Parameter	Symbol	Typ	Max	Units
Maximum Junction-to-Ambient ^A	$R_{\theta JA}$	16.7	25	$^\circ\text{C/W}$
Maximum Junction-to-Ambient ^A		Steady-State	40	50
Maximum Junction-to-Case ^D	$R_{\theta JC}$	2.5	3	$^\circ\text{C/W}$

Electrical Characteristics ($T_J=25^\circ\text{C}$ unless otherwise noted)

Symbol	Parameter	Conditions	Min	Typ	Max	Units
STATIC PARAMETERS						
BV_{DSS}	Drain-Source Breakdown Voltage	$I_D=-250\mu\text{A}$, $V_{GS}=0\text{V}$	-30			V
I_{DSS}	Zero Gate Voltage Drain Current	$V_{DS}=-24\text{V}$, $V_{GS}=0\text{V}$			-1	μA
		$T_J=55^\circ\text{C}$			-5	
I_{GSS}	Gate-Body leakage current	$V_{DS}=0\text{V}$, $V_{GS}=\pm 20\text{V}$			± 100	nA
$V_{GS(th)}$	Gate Threshold Voltage	$V_{DS}=V_{GS}$, $I_D=-250\mu\text{A}$	-1	-1.9	-3	V
$I_{D(ON)}$	On state drain current	$V_{GS}=-10\text{V}$, $V_{DS}=-5\text{V}$	-60			A
$R_{DS(ON)}$	Static Drain-Source On-Resistance	$V_{GS}=-10\text{V}$, $I_D=-20\text{A}$		27	34	m Ω
		$T_J=125^\circ\text{C}$		36		
		$V_{GS}=-4.5\text{V}$, $I_D=-7\text{A}$		40	55	m Ω
g_{FS}	Forward Transconductance	$V_{DS}=-5\text{V}$, $I_D=-20\text{A}$		18		S
V_{SD}	Diode Forward Voltage	$I_S=-1\text{A}$, $V_{GS}=0\text{V}$		-0.75	-1	V
I_S	Maximum Body-Diode Continuous Current				-6	A
DYNAMIC PARAMETERS						
C_{iss}	Input Capacitance	$V_{GS}=0\text{V}$, $V_{DS}=-15\text{V}$, $f=1\text{MHz}$		920		pF
C_{oss}	Output Capacitance			140		pF
C_{rss}	Reverse Transfer Capacitance			90		pF
R_g	Gate resistance	$V_{GS}=0\text{V}$, $V_{DS}=0\text{V}$, $f=1\text{MHz}$		6	9	Ω
SWITCHING PARAMETERS						
$Q_{g(10V)}$	Total Gate Charge (10V)	$V_{GS}=-10\text{V}$, $V_{DS}=-15\text{V}$, $I_D=-20\text{A}$		16.2		nC
$Q_{g(4.5V)}$	Total Gate Charge (4.5V)			8.2		nC
Q_{gs}	Gate Source Charge			2.9		nC
Q_{gd}	Gate Drain Charge			3.6		nC
$t_{D(on)}$	Turn-On Delay Time			8		ns
t_r	Turn-On Rise Time	$V_{GS}=-10\text{V}$, $V_{DS}=-15\text{V}$, $R_L=0.75\Omega$,		30		ns
$t_{D(off)}$	Turn-Off Delay Time	$R_{GEN}=0.75\Omega$		22		ns
t_f	Turn-Off Fall Time			26		ns
t_{rr}	Body Diode Reverse Recovery Time	$I_F=-20\text{A}$, $dI/dt=100\text{A}/\mu\text{s}$		23		ns
Q_{rr}	Body Diode Reverse Recovery Charge	$I_F=-20\text{A}$, $dI/dt=100\text{A}/\mu\text{s}$		14		nC

A: The value of $R_{\theta JA}$ is measured with the device mounted on 1 in 2 FR-4 board with 2oz. Copper, in a still air environment with $T_A=25^\circ\text{C}$. The Power dissipation P_{DSM} is based on $R_{\theta JA}$ (<10s) and the maximum allowed junction temperature of 150°C . The value in any given application depends on the user's specific board design, and the maximum temperature of 175°C may be used if the PCB allows it.

B: The power dissipation P_D is based on $T_{J(MAX)}=175^\circ\text{C}$, using junction-to-case thermal resistance, and is more useful in setting the upper dissipation limit for cases where additional heatsinking is used.

C: Repetitive rating, pulse width limited by junction temperature $T_{J(MAX)}=175^\circ\text{C}$.

D: The $R_{\theta JA}$ is the sum of the thermal impedance from junction to case $R_{\theta JC}$ and case to ambient.

E: The static characteristics in Figures 1 to 6 are obtained using <300 μs pulses, duty cycle 0.5% max.

F: These curves are based on the junction-to-case thermal impedance which is measured with the device mounted to a large heatsink, assuming a maximum junction temperature of $T_{J(MAX)}=175^\circ\text{C}$.

G: The maximum current rating is limited by bond-wires.

H: These tests are performed with the device mounted on 1 in 2 FR-4 board with 2oz. Copper, in a still air environment with $T_A=25^\circ\text{C}$. The SOA curve provides a single pulse rating.

*This device is guaranteed green after data code 8X11 (Sep 1ST 2008).

Rev1: Sep. 2008

THIS PRODUCT HAS BEEN DESIGNED AND QUALIFIED FOR THE CONSUMER MARKET. APPLICATIONS OR USES AS CRITICAL COMPONENTS IN LIFE SUPPORT DEVICES OR SYSTEMS ARE NOT AUTHORIZED. AOS DOES NOT ASSUME ANY LIABILITY ARISING OUT OF SUCH APPLICATIONS OR USES OF ITS PRODUCTS. AOS RESERVES THE RIGHT TO IMPROVE PRODUCT DESIGN, FUNCTIONS AND RELIABILITY WITHOUT NOTICE.

TYPICAL ELECTRICAL AND THERMAL CHARACTERISTICS

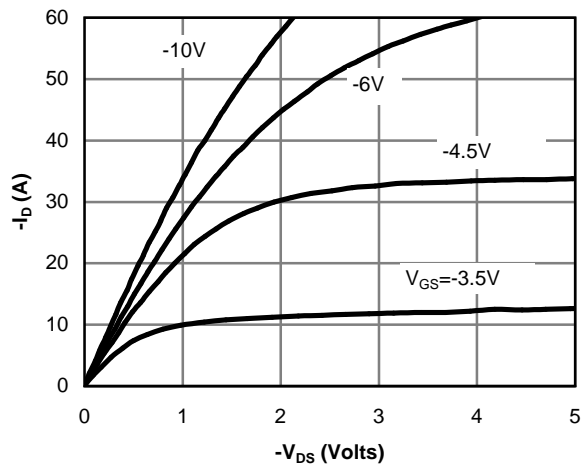

Figure 1: On-Region Characteristics

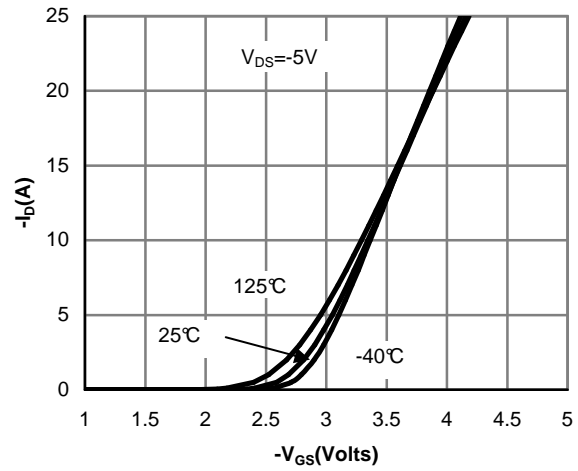

Figure 2: Transfer Characteristics

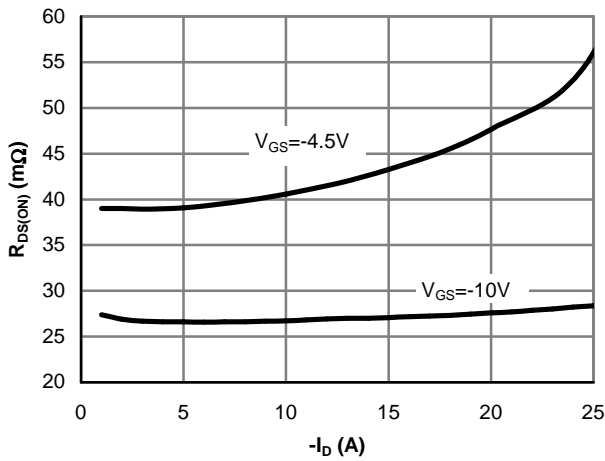

Figure 3: On-Resistance vs. Drain Current and Gate Voltage

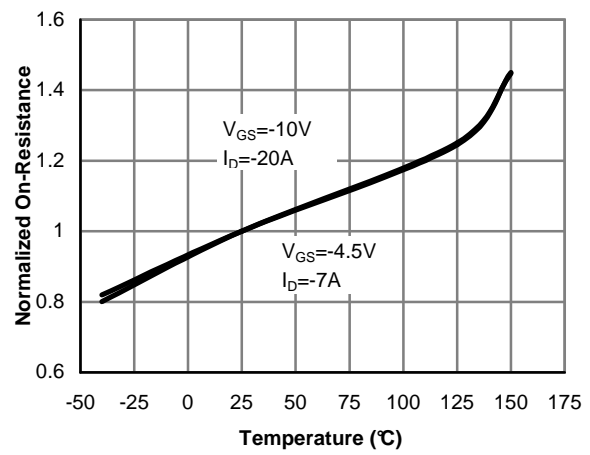

Figure 4: On-Resistance vs. Junction Temperature

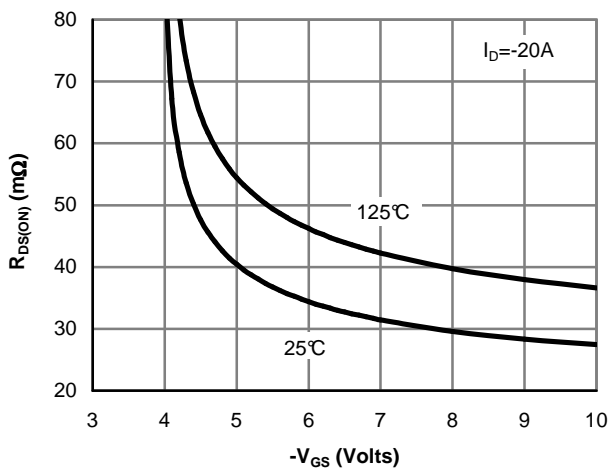

Figure 5: On-Resistance vs. Gate-Source Voltage

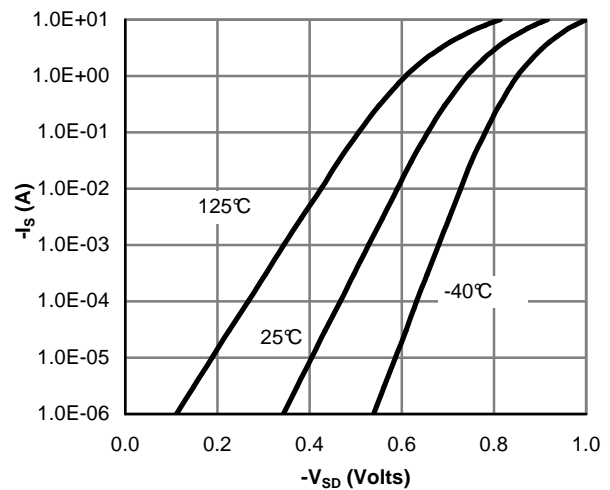

Figure 6: Body-Diode Characteristics

TYPICAL ELECTRICAL AND THERMAL CHARACTERISTICS

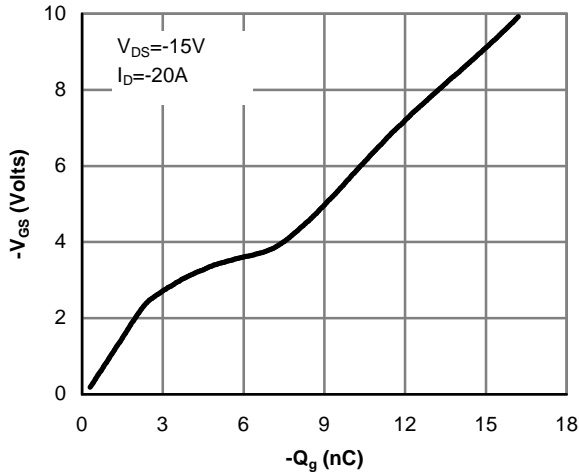

Figure 7: Gate-Charge Characteristics

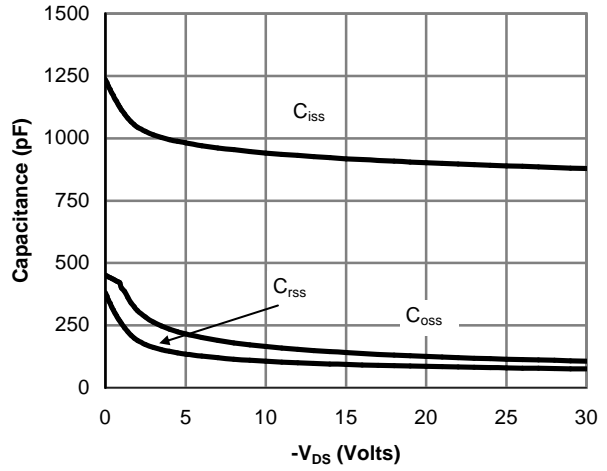

Figure 8: Capacitance Characteristics

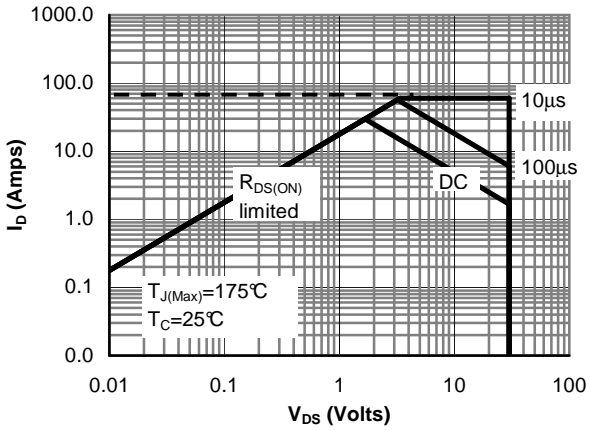

Figure 9: Maximum Forward Biased Safe Operating Area (Note F)

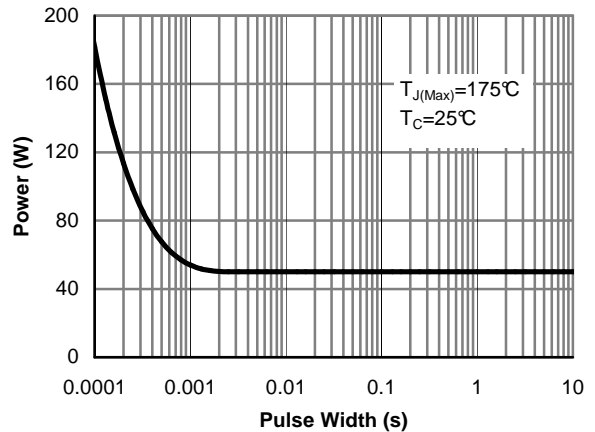

Figure 10: Single Pulse Power Rating Junction-to-Case (Note F)

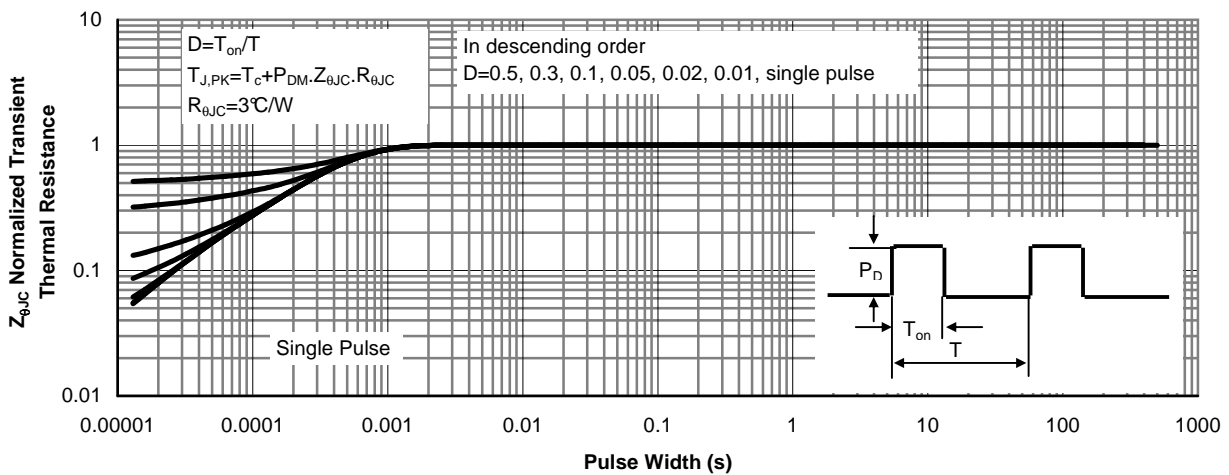

Figure 11: Normalized Maximum Transient Thermal Impedance (Note F)

TYPICAL ELECTRICAL AND THERMAL CHARACTERISTICS

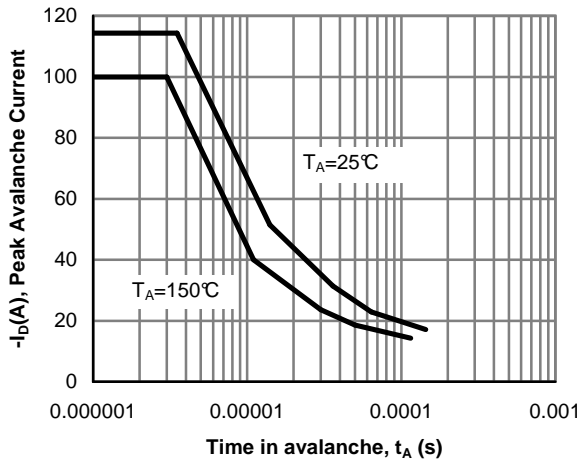

Figure 12: Single Pulse Avalanche capability

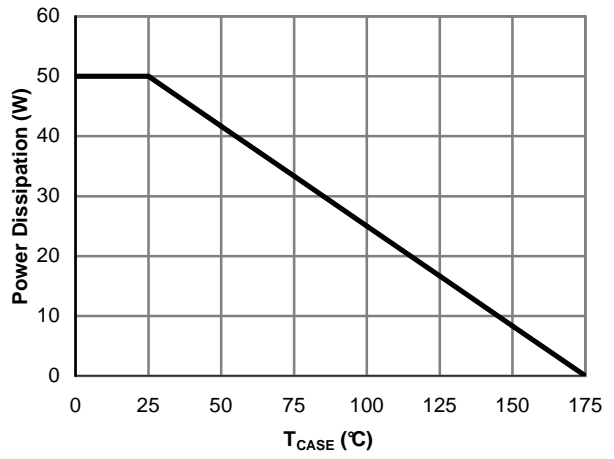

Figure 13: Power De-rating (Note B)

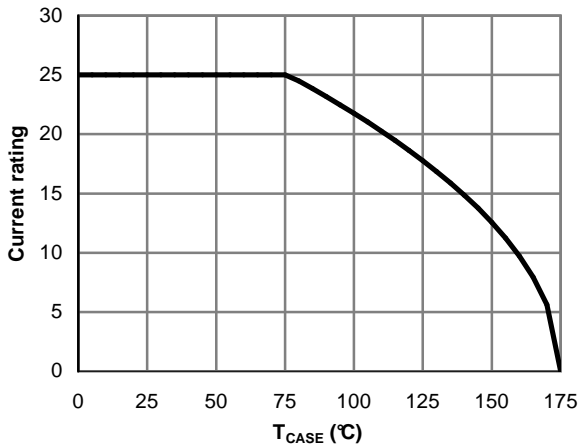

Figure 14: Current De-rating (Note B)

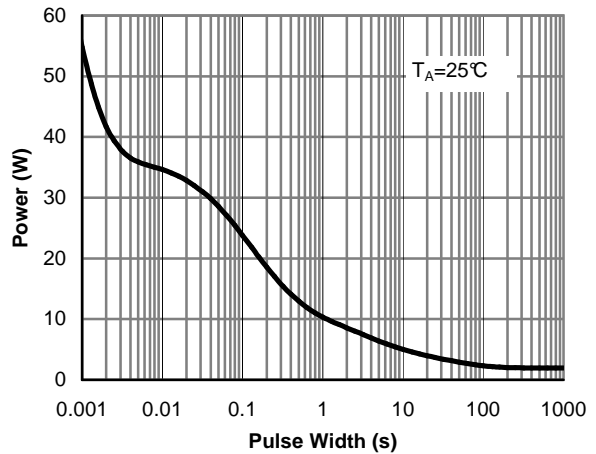

Figure 15: Single Pulse Power Rating Junction-to-Ambient (Note H)

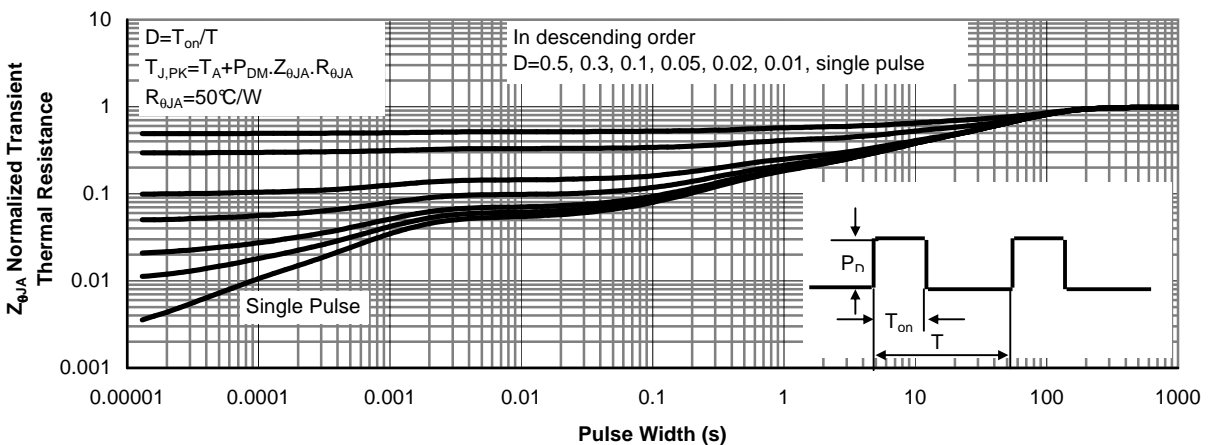
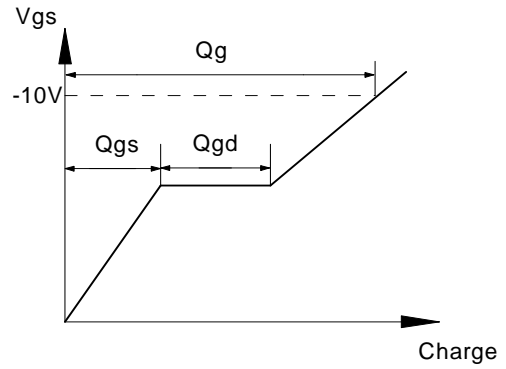
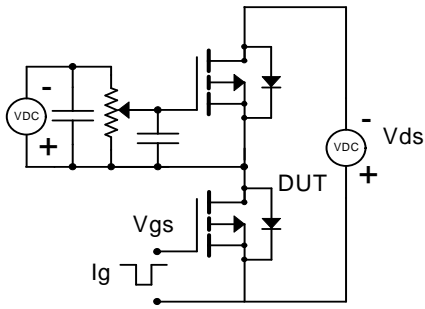
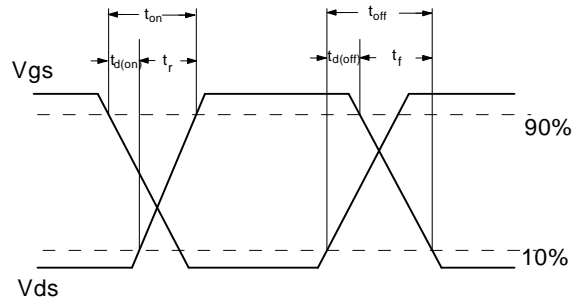
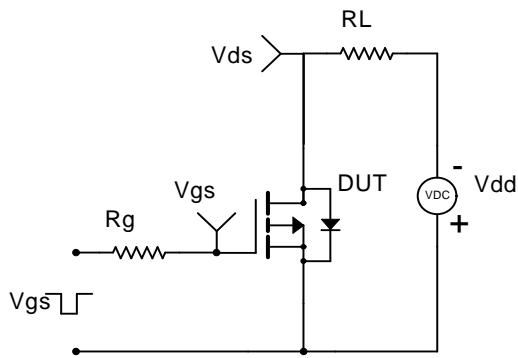

Figure 16: Normalized Maximum Transient Thermal Impedance (Note H)

Gate Charge Test Circuit & Waveform



Resistive Switching Test Circuit & Waveforms



Unclamped Inductive Switching (UIS) Test Circuit & Waveforms

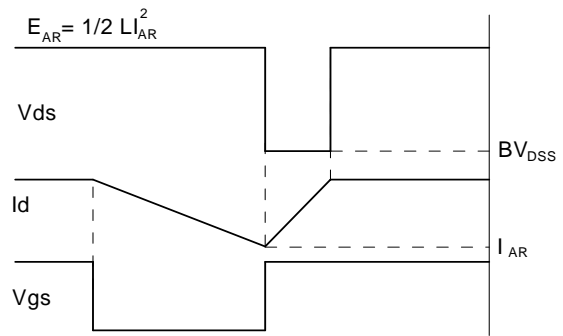
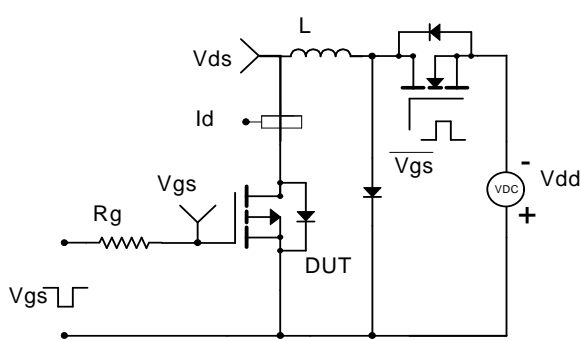

Diode Recovery Test Circuit & Waveforms

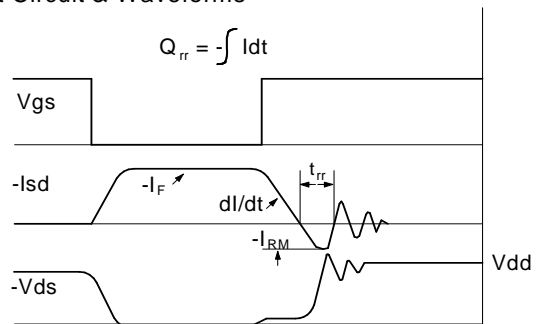
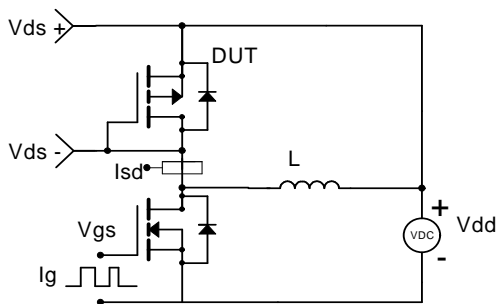



Document No.	PD-00513
Version	C
Title	AOD417 Marking Description

DPAK PACKAGE MARKING DESCRIPTION

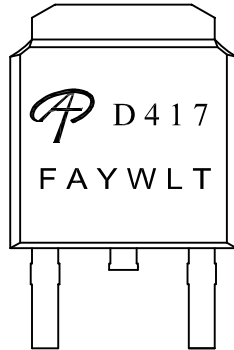

Green product

NOTE:
LOGO - AOS Logo
D417 - Part number code
F - Fab code
A - Assembly location code
Y - Year code
W - Week code
L&T - Assembly lot code

PART NO.	DESCRIPTION	CODE
AOD417	Green product	D417
AOD417L	Green product	D417



TO252(DPAK) PACKAGE OUTLINE

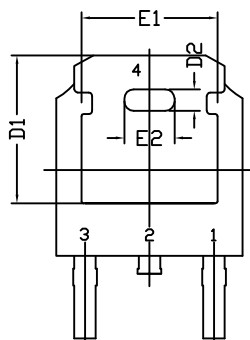
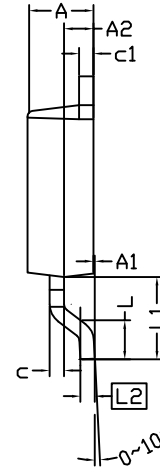
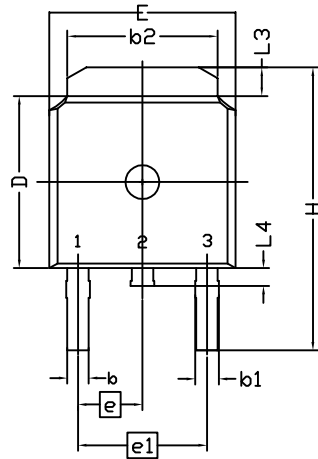

SYMBOL	DIMENSION IN MILLIMETERS			DIMENSIONS IN INCHES		
	MIN.	NOM.	MAX.	MIN.	NOM.	MAX.
A	2.184	2.286	2.388	0.086	0.090	0.094
A1	0.000	-----	0.127	0.000	-----	0.005
A2	0.889	1.041	1.143	0.035	0.041	0.045
b	0.635	0.762	0.889	0.025	0.030	0.035
b1	0.762	0.840	1.143	0.030	0.033	0.045
b2	4.953	5.340	5.461	0.195	0.210	0.215
c	0.450	0.508	0.610	0.018	0.020	0.024
c1	0.450	0.508	0.610	0.018	0.020	0.024
D	5.969	6.096	6.223	0.235	0.240	0.245
D1	5.210	5.249	5.380	0.205	0.207	0.212
D2	0.662	0.762	0.862	0.026	0.030	0.034
E	6.350	6.604	6.731	0.250	0.260	0.265
E1	4.318	4.826	4.901	0.170	0.190	0.193
E2	1.678	1.778	1.878	0.066	0.070	0.074
e	2.286 BSC			0.090 BSC		
e1	4.572 BSC			0.180 BSC		
H	9.398	10.033	10.414	0.370	0.395	0.410
L	1.270	1.520	2.032	0.050	0.060	0.080
L1	2.921 REF.			0.115REF.		
L2	0.408	0.508	0.608	0.016	0.020	0.024
L3	0.889	1.016	1.270	0.035	0.040	0.050
L4	0.635	-----	1.016	0.025	-----	0.040

RECOMMENDED LAND PATTERN

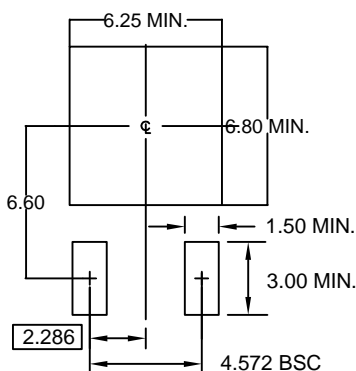

UNIT: mm

NOTE

1. PACKAGE BODY SIZES EXCLUDE MOLD FLASH AND GATE BURRS. MOLD FLASH SHOULD BE LESS THAN 6 MILS.
2. DIMENSION L IS MEASURED IN GAUGE PLANE
3. TOLERANCE 0.10 mm UNLESS OTHERWISE SPECIFIED
4. CONTROLLING DIMENSION IS MILLIMETER. CONVERTED INCH DIMENSIONS ARE NOT NECESSARILY EXACT.
5. REFER TO JEDEC TO-252 (AA)



DPAK Carrier Tape

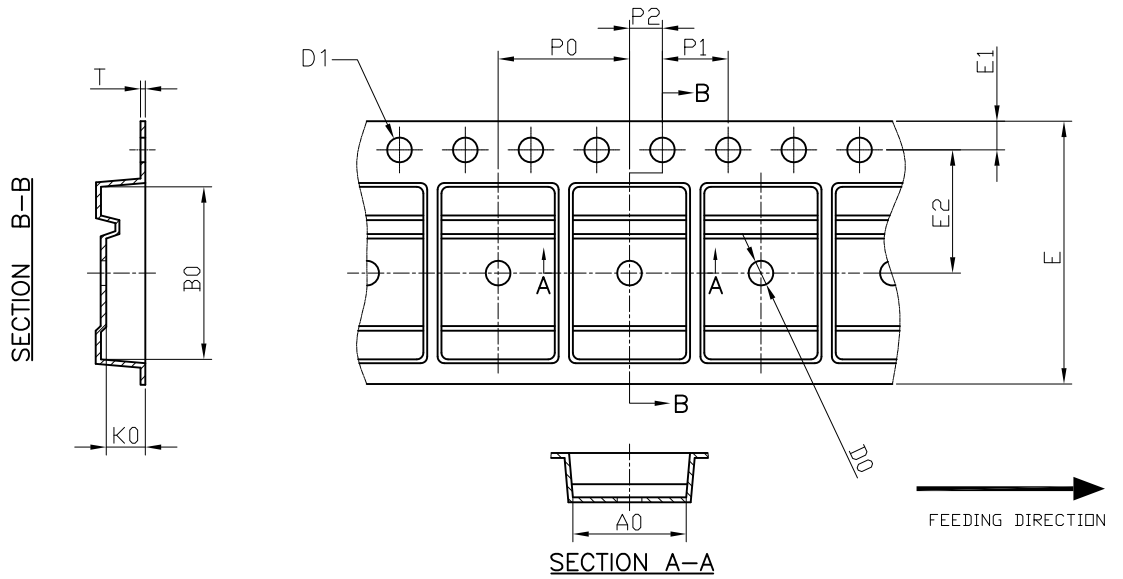

UNIT: MM

PACKAGE	A0	B0	K0	D0	D1	E	E1	E2	P0	P1	P2	T
DPAK (16 mm)	6.90 ±0.10	10.50 ±0.10	2.50 ±0.10	1.50 +0.1 -0	1.50 +0.1 -0	16.00 ±0.30	1.75 ±0.10	7.50 ±0.10	8.00 ±0.10	4.00 ±0.10	2.00 ±0.10	0.30 ±0.05

DPAK Reel

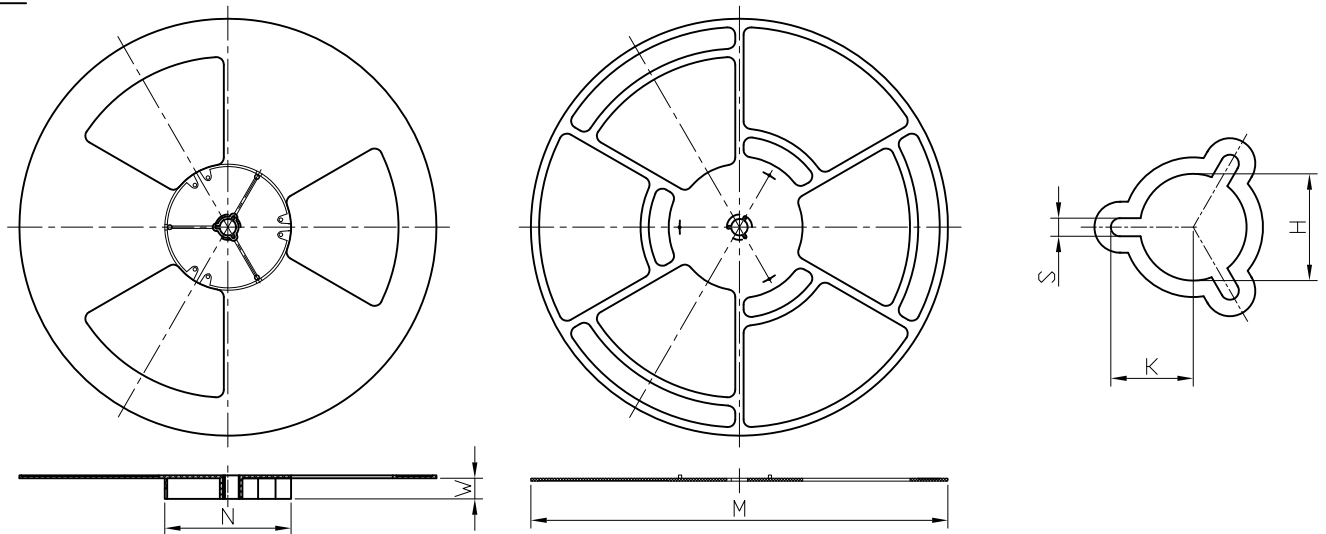

UNIT: MM

TAPE SIZE	REEL SIZE	M	N	W	H	K	S
16 mm	ø330	ø330.00 +0.25 -4.00	ø100.00 ±0.2	16.4 +2.0 -0.0	ø13.00 +0.50 -0.20	10.5 ±0.25	2.2 ±0.25

DPAK Tape

Leader / Trailer
& Orientation

Unit Per Reel:
2500pcs

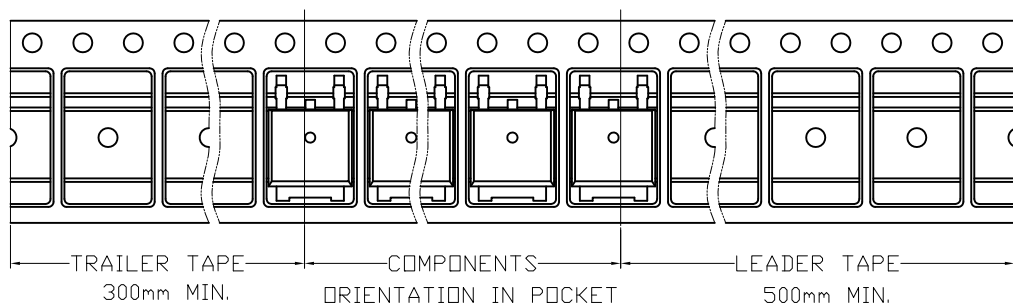



AOS Semiconductor Product Reliability Report

AOD417 rev B

Plastic Encapsulated Device

ALPHA & OMEGA Semiconductor, Inc

**495 Mercury Drive
Sunnyvale, CA 94085
U.S.**

Tel: (408) 830-9742

www.aosmd.com

This AOS product reliability report summarizes the qualification result for AOD417. Accelerated environmental tests are performed on a specific sample size, and then followed by electrical test at end point. Review of final electrical test result confirms that AOD417 passes AOS quality and reliability requirements. The released product will be categorized by the process family and be monitored on a quarterly basis for continuously improving the product quality.

Table of Contents:

- I. Product Description
- II. Package and Die information
- III. Environmental Stress Test Summary and Result
- IV. Reliability Evaluation

I. Product Description:

The AOD417 uses advanced trench technology to provide excellent $R_{DS(ON)}$, low gate charge and low gate resistance. With the excellent thermal resistance of the DPAK package, this device is well suited for high current load applications.

- RoHS Compliant
- Halogen Free

Absolute Maximum Ratings $T_A=25^\circ\text{C}$ unless otherwise noted			
Parameter	Symbol	Maximum	Units
Drain-Source Voltage	V_{DS}	-30	V
Gate-Source Voltage	V_{GS}	± 20	V
Continuous Drain Current ^{B,G}	$T_A=25^\circ\text{C}$ ^G	-25	A
	$T_A=100^\circ\text{C}$	-20	
Pulsed Drain Current ^C	I_{DM}	-60	
Avalanche Current ^C	I_{AR}	-14	A
Repetitive avalanche energy $L=0.3\text{mH}$ ^C	E_{AR}	30	mJ
Power Dissipation ^B	$T_C=25^\circ\text{C}$	50	W
	$T_C=100^\circ\text{C}$	25	
Power Dissipation ^A	$T_A=25^\circ\text{C}$	2.5	W
	$T_A=70^\circ\text{C}$	1.6	
Junction and Storage Temperature Range	T_J, T_{STG}	-55 to 175	$^\circ\text{C}$

Thermal Characteristics					
Parameter		Symbol	Typ	Max	Units
Maximum Junction-to-Ambient ^A	$t \leq 10\text{s}$	$R_{\theta JA}$	16.7	25	$^\circ\text{C/W}$
Maximum Junction-to-Ambient ^A	Steady-State		40	50	$^\circ\text{C/W}$
Maximum Junction-to-Case ^D	Steady-State	$R_{\theta JC}$	2.5	3	$^\circ\text{C/W}$

II. Die / Package Information:

	AOD417
Process	Standard sub-micron Low voltage P channel process
Package Type	3 leads TO252
Lead Frame	Bare Cu
Die Attach	Soft solder
Bond wire	S: Al, 12mils; G: Au, 1.3mils
Mold Material	Epoxy resin with silica filler
Flammability Rating	UL-94 V-0
Backside Metallization	Ti / Ni / Ag
Moisture Level	Up to Level 1 *

Note * based on info provided by assembler and mold compound supplier

III. Result of Reliability Stress for AOD417

Test Item	Test Condition	Time Point	Lot Attribution	Total Sample size	Number of Failures
Solder Reflow Precondition	168hr 85°c /85%RH +3 cycle reflow@260°c	-	9 lots	1210pcs	0
HTGB	Temp = 150°c , Vgs=100% of Vgsmax	168 / 500 hrs 1000 hrs	1 lot (Note A*)	82pcs 77+5 pcs / lot	0
HTRB	Temp = 150°c , Vds=80% of Vdsmax	168 / 500 hrs 1000 hrs	1 lot (Note A*)	82pcs 77+5 pcs / lot	0
HAST	130 +/- 2°c , 85%RH, 33.3 psi, Vgs = 80% of Vgs max	100 hrs	9 lots (Note B*)	495pcs 50+5 pcs / lot	0
Pressure Pot	121°c , 29.7psi, 100%RH	96 hrs	5 lots (Note B*)	275pcs 50+5 pcs / lot	0
Temperature Cycle	-65°c to 150°c , air to air,	250 / 500 cycles	8 lots (Note B*)	440pcs 50+5 pcs / lot	0

III. Result of Reliability Stress for AOD417

Continues

DPA	Internal Vision Cross-section X-ray	NA	5 5 5	5 5 5	0
CSAM		NA	5	5	0
Bond Integrity	Room Temp 150°C bake 150°C bake	0hr 250hr 500hr	40 40 40	40 wires 40 wires 40 wires	0
Solderability	245°C	5 sec	15	15 leads	0
Solder dunk	260°C	10secs 3 cycles	1	30 units	0

Note A: The HTGB and HTRB reliability data presents total of available AOD417 burn-in data up to the published date.

Note B: The pressure pot, temperature cycle, HAST and HTS reliability data for AOD417 comes from the AOS generic package qualification data.

IV. Reliability Evaluation

FIT rate (per billion): 128

MTTF = 891 years

The presentation of FIT rate for the individual product reliability is restricted by the actual burn-in sample size of the selected product (AOD417). Failure Rate Determination is based on JEDEC Standard JESD 85. FIT means one failure per billion device hours.

$$\text{Failure Rate} = \text{Chi}^2 \times 10^9 / [2 (N) (H) (Af)] = 1.83 \times 10^9 / [2 (164) (168) (258)] = 128$$

$$\text{MTTF} = 10^9 / \text{FIT} = 7.81 \times 10^6 \text{hrs} = 891 \text{ years}$$

Chi² = Chi Squared Distribution, determined by the number of failures and confidence interval

N = Total Number of units from HTRB and HTGB tests

H = Duration of HTRB/HTGB testing

Af = Acceleration Factor from Test to Use Conditions (Ea = 0.7eV and Tuse = 55°C)

$$\text{Acceleration Factor [Af]} = \text{Exp} [Ea / k (1/Tj u - 1/Tj s)]$$

Acceleration Factor ratio list:

	55 deg C	70 deg C	85 deg C	100 deg C	115 deg C	130 deg C	150 deg C
Af	258	87	32	13	5.64	2.59	1

Tj s = Stressed junction temperature in degree (Kelvin), K = C+273.16

Tj u = The use junction temperature in degree (Kelvin), K = C+273.16

k = Boltzmann's constant, 8.617164 X 10⁻⁵eV / K