

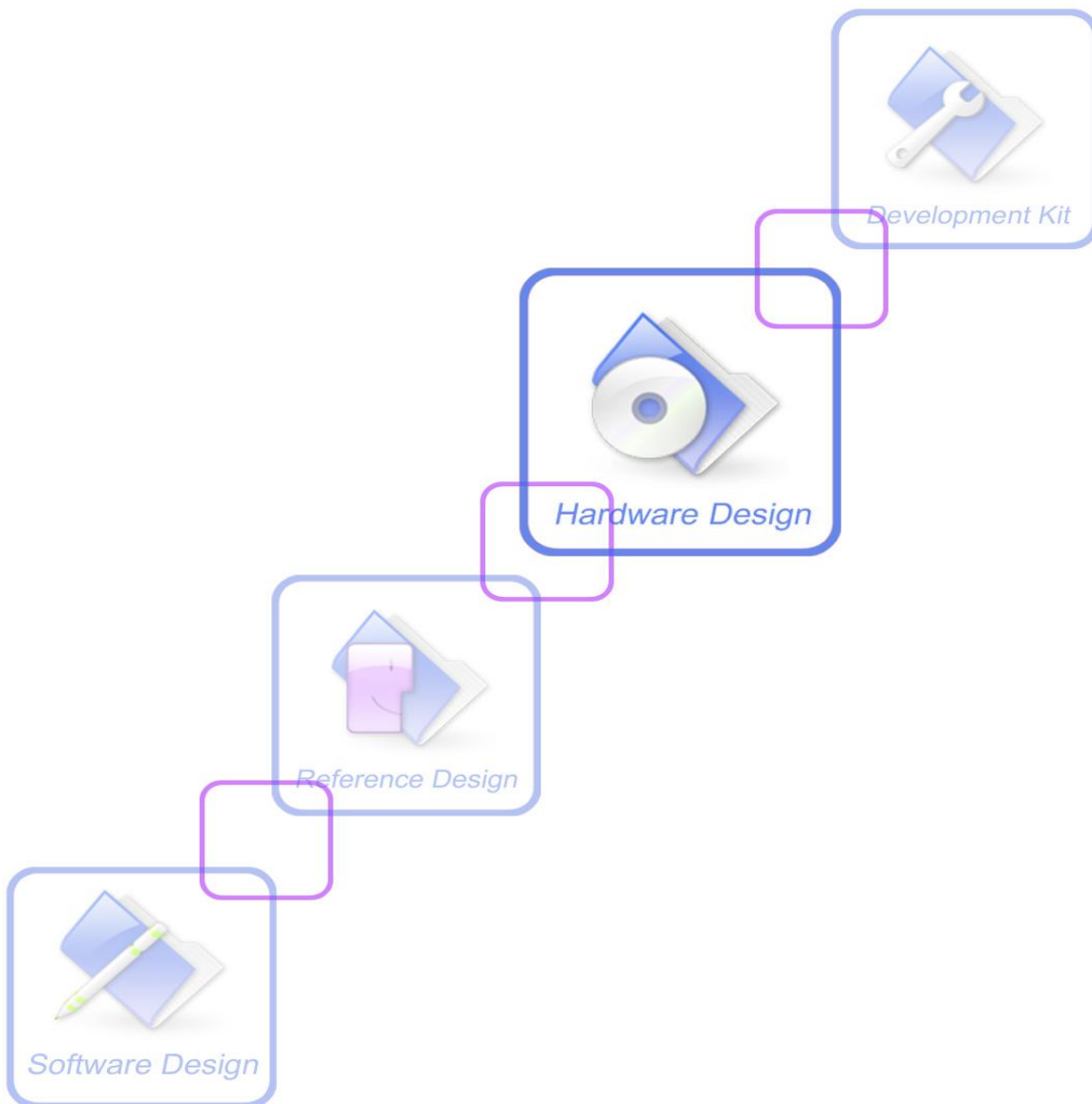

A company of SIM Tech

## SIM7100-PCIE\_Hardware Design\_V1.02



<b>Document Title</b>	SIM7100-PCIE Hardware Design
<b>Version</b>	1.02
<b>Date</b>	2016-03-24
<b>Status</b>	Released
<b>Document Control ID</b>	SIM7100-PCIE_Hardware_Design_V1.02

### General Notes

SIMCom offers this information as a service to its customers to support the application and engineering efforts that use the products designed by SIMCom. The information provided is based on the requirements specifically from the customers. SIMCom has not undertaken any independent search for additional relevant information, including any information that may be in the customer's possession. Furthermore, the system validation of the product designed by SIMCom within a larger electronic system remains the responsibility of the customer or the customer's system integrator. All specifications supplied herein are subject to change without notice.

### Copyright

This document contains the proprietary technical information which is the property of SIMCom Limited, copying of this document, giving it to others, the using or communication of the contents thereof are forbidden without the official authority by SIMCom. Offenders are liable to the payment of the damages. All rights are reserved in the event of grant of a patent or the registration of a utility model or design. All specifications supplied herein are subject to change without notice

*Copyright © SIMCom Wireless Solutions Co., Ltd. 2016*

# Contents

<b>General Notes</b> .....	<b>2</b>
<b>Copyright</b> .....	<b>2</b>
<b>Contents</b> .....	<b>3</b>
<b>Table Index</b> .....	<b>5</b>
<b>Figure Index</b> .....	<b>6</b>
<b>Version History</b> .....	<b>7</b>
<b>1 Introduction</b> .....	<b>8</b>
1.1 Product Outline.....	8
1.2 Hardware Interface Overview.....	9
1.3 Hardware Block Diagram.....	10
1.4 Functional Overview.....	10
<b>2 Package Information</b> .....	<b>13</b>
2.1 Pin Out Diagram.....	13
2.2 PCI Express Mini Card Connector Pin Description.....	13
2.3 Package Dimensions.....	15
<b>3 Interface Application</b> .....	<b>16</b>
3.1 Power Supply.....	16
3.2 PERST#.....	16
3.3 W_DISABLE#.....	17
3.4 LED_WWAN#.....	17
3.5 WAKE#.....	18
3.6 USB 2.0.....	19
3.6.1 USB Application Guide.....	19
3.7 USIM Interface.....	20
3.7.1 USIM Application Guide.....	21
3.8 UART Interface.....	22
3.9 I2C Interface.....	23
3.9.1 I2C Design Guide.....	23
3.10 PCM/Analog Audio Interface.....	24
3.10.1 PCM Interface.....	24
3.10.2 PCM timing.....	25
3.10.3 PCM Application Guide.....	26
3.10.4 Analog Audio Interface.....	26
<b>4 RF Specifications</b> .....	<b>28</b>
4.1 GSM/WCDMA/TD-SCDMA/EVDO/LTE RF Specifications.....	28
4.2 RF Antenna Connector.....	32
4.3 GNSS (GPS and GLONASS).....	34
4.3.1 GNSS Technical specification.....	34
4.3.2 GNSS Operate Mode.....	34
<b>5 Electrical Specifications</b> .....	<b>37</b>
5.1 Absolute Maximum Ratings.....	37
5.2 Recommended Operating Conditions.....	37

5.3	Operating Mode.....	37
5.3.1	Operating Mode .....	37
5.3.2	Power saving mode .....	38
5.3.3	Sleep mode.....	38
5.3.4	Minimum functionality mode.....	38
5.4	Current Consumption .....	39
5.5	Electro-Static Discharge .....	41
<b>Appendix</b>	.....	<b>42</b>
I.	Coding Schemes and Maximum Net Data Rates over Air Interface .....	42
II.	Related Documents.....	45
III.	Terms and Abbreviations .....	47
IV.	Safety Caution .....	49

SIMCOM CONFIDENTIAL FILE

## Table Index

TABLE 1: SIM7100-PCIE SERIES FREQUENCY BANDS .....	8
TABLE 2: SIM7100-PCIE KEY FEATURES .....	10
TABLE 3: PCI EXPRESS MINI CARD CONNECTOR PIN DESCRIPTION .....	13
TABLE 4: RECOMMENDED 3.3V POWER SUPPLY CHARACTERISTICS .....	16
TABLE 5: PERST# PIN ELECTRONIC CHARACTERISTIC.....	16
TABLE 6: W_DISABLE# PIN STATUS .....	17
TABLE 7: W_DISABLE# PIN ELECTRICAL CHARACTERISTIC.....	17
TABLE 8: NETWORK STATUS INDICATION LED STATUS.....	17
TABLE 9: USIM ELECTRONIC CHARACTERISTIC IN 1.8V MODE (USIM_VDD =1.8V) .....	20
TABLE 10: USIM ELECTRONIC CHARACTERISTIC 3.0V MODE (USIM_VDD =2.95V) .....	20
TABLE 11: UART ELECTRICAL CHARACTERISTIC .....	22
TABLE 12: I2C ELECTRICAL CHARACTERISTIC.....	24
TABLE 13: PCM SPECIFICATION .....	24
TABLE 14: PCM DC CHARACTERISTICS .....	24
TABLE 15: PCM TIMING PARAMETERS .....	25
TABLE 16: MIC INPUT CHARACTERISTICS .....	26
TABLE 17: AUDIO OUTPUT CHARACTERISTICS .....	27
TABLE 18: CONDUCTED TRANSMISSION POWER.....	28
TABLE 19: OPERATING FREQUENCIES.....	28
TABLE 20: E-UTRA OPERATING BANDS.....	29
TABLE 21: CONDUCTED RECEIVE SENSITIVITY .....	30
TABLE 22: REFERENCE SENSITIVITY (QPSK).....	30
TABLE 23: RECOMMENDED PASSIVE ANTENNA CHARACTERISTICS .....	32
TABLE 24: RECOMMENDED ACTIVE ANTENNA CHARACTERISTICS .....	32
TABLE 25: ABSOLUTE MAXIMUM RATINGS.....	37
TABLE 26: OPERATING CONDITIONS .....	37
TABLE 27: OPERATING MODE.....	37
TABLE 28: CURRENT CONSUMPTION(VCC =3.3V+0.3V/-0.3V) .....	39
TABLE 29: ESD CHARACTERISTICS (TEMPERATURE: 25°C, HUMIDITY: 45 %)... ..	41
TABLE 30: CODING SCHEMES AND MAXIMUM NET DATA RATES OVER AIR INTERFACE .....	42
TABLE 31: RELATED DOCUMENTS .....	45
TABLE 32: TERMS AND ABBREVIATIONS.....	47
TABLE 33: SAFETY CAUTION.....	49

## Figure Index

FIGURE 1: SIM7100-PCIE BLOCK DIAGRAM .....	10
FIGURE 2: SIM7100-PCIE PIN OUT DIAGRAM .....	13
FIGURE 3: DIMENSIONS OF SIM7100-PCIE (UNIT: MM) .....	15
FIGURE 4: PERST# REFERENCE CIRCUIT .....	16
FIGURE 5: W_DISABLE# REFERENCE CIRCUIT .....	17
FIGURE 6: LED_WWAN# REFERENCE CIRCUIT .....	18
FIGURE 7: WAKE# BEHAVIOUR .....	18
FIGURE 8: WAKE# BEHAVIOR AS A CALLER .....	19
FIGURE 9: WAKE# REFERENCE CIRCUIT .....	19
FIGURE 10: USB REFERENCE CIRCUIT .....	20
FIGURE 11: USIM INTERFACE REFERENCE CIRCUIT WITH DETECTION FUNCTION .....	21
FIGURE 12: USIM INTERFACE REFERENCE CIRCUIT .....	21
FIGURE 13: UART FULL MODEM .....	22
FIGURE 14: UART NULL MODEM .....	22
FIGURE 15: REFERENCE CIRCUIT OF LEVEL SHIFT .....	23
FIGURE 16: I2C REFERENCE CIRCUIT .....	24
FIGURE 17: PCM_SYNC TIMING .....	25
FIGURE 18: EXT CODEC TO MODULE TIMING .....	25
FIGURE 19: MODULE TO EXT CODEC TIMING .....	25
FIGURE 20: AUDIO CODEC REFERENCE CIRCUIT .....	26
FIGURE 21: RECEIVER INTERFACE CONFIGURATION .....	27
FIGURE 22: MICROPHONE INTERFACE CONFIGURATION .....	27
FIGURE 23: U.FL-R-SMT .....	33
FIGURE 24: U.FL SERIES RF ADAPTER CABLE .....	33

SIMCOM CONFIDENTIAL FILE

## Version History

Date	Version	Description of change	Author
2015-04-07	1.01	Origin	Ye Haibing Xing Lei
2016-03-24	1.02	更新 SIM7100CE, SIM7100V 的频段信息	Ma Honggang

SIMCOM CONFIDENTIAL FILE

# 1 Introduction

This document describes the electronic specifications, RF specifications, interfaces, mechanical characteristics and testing results of the SIMCom SIM7100-PCIE modules. With the help of this document and other related software application notes/user guides, users can understand and use SIM7100-PCIE modules to design and develop applications quickly.

## 1.1 Product Outline

Aimed at global market, the SIM7100-PCIE modules support 5 air-interface standards including GSM, TD-SCDMA, CDMA, WCDMA and LTE. Users can choose the module according to the wireless network configuration. The supported radio frequency bands are described in the following table.

**Table 1: SIM7100-PCIE Series Frequency Bands**

Standard	Frequency	SIM7100x-PCIE(A)*						
		x="C"	x="CE"	x="E"	x="JE"	x="JC"	x="V"	x="A"
GSM	GSM 850MHz							
	EGSM 900MHz	✓	✓	✓	✓	✓		
	DCS 1800MHz	✓	✓	✓	✓	✓		
	PCS 1900MHz							
CDMA2000/ EVDO	BC0		✓					
WCDMA	BAND5							✓
	BAND6					✓		
	BAND8	✓	✓	✓	✓	✓		
	BAND2							✓
	BAND1	✓	✓	✓	✓	✓		
TD-SCDMA	TD-SCDMA 1.9G	✓	✓					
	TD-SCDMA 2G	✓	✓					
LTE-FDD	LTE-FDD B1	✓	✓	✓	✓	✓		
	LTE-FDD B2							✓
	LTE-FDD B3	✓	✓	✓		✓	✓	
	LTE-FDD B4						✓	✓
	LTE-FDD B5							✓
	LTE-FDD B7	✓		✓				



	LTE-FDD B8	✓	✓	✓	✓	✓		
	LTE-FDD B13							
	LTE-FDD B17							✓
	LTE-FDD B18					✓		
	LTE-FDD B19					✓		
	LTE-FDD B20			✓				
LTE-TDD	LTE TDD B38	✓	✓	✓				
	LTE TDD B39	✓	✓					
	LTE TDD B40	✓	✓	✓				
	LTE TDD B41	✓	✓			✓		
GNSS	GPS	✓	✓	✓		✓		✓
	GLONASS	✓	✓	✓		✓		✓

*\*Note: If Analog audio is needed, please consult our sales staff, for more information .*

## 1.2 Hardware Interface Overview

SIM7100-PCIE provides various hardware interfaces via Mini PCI Express card connector.

- **Power Supply**
- **PERST#**
- **W\_DISABLE#**
- **LED\_WWAN#**
- **WAKE#**
- **USB Interface**
- **USIM Interface**
- **UART Interface**
- **I2C Interface**
- **PCM Interface**
- **Analog Audio Interface**

### 1.3 Hardware Block Diagram

The following figure is SIM7100-PCIE hardware block diagram.

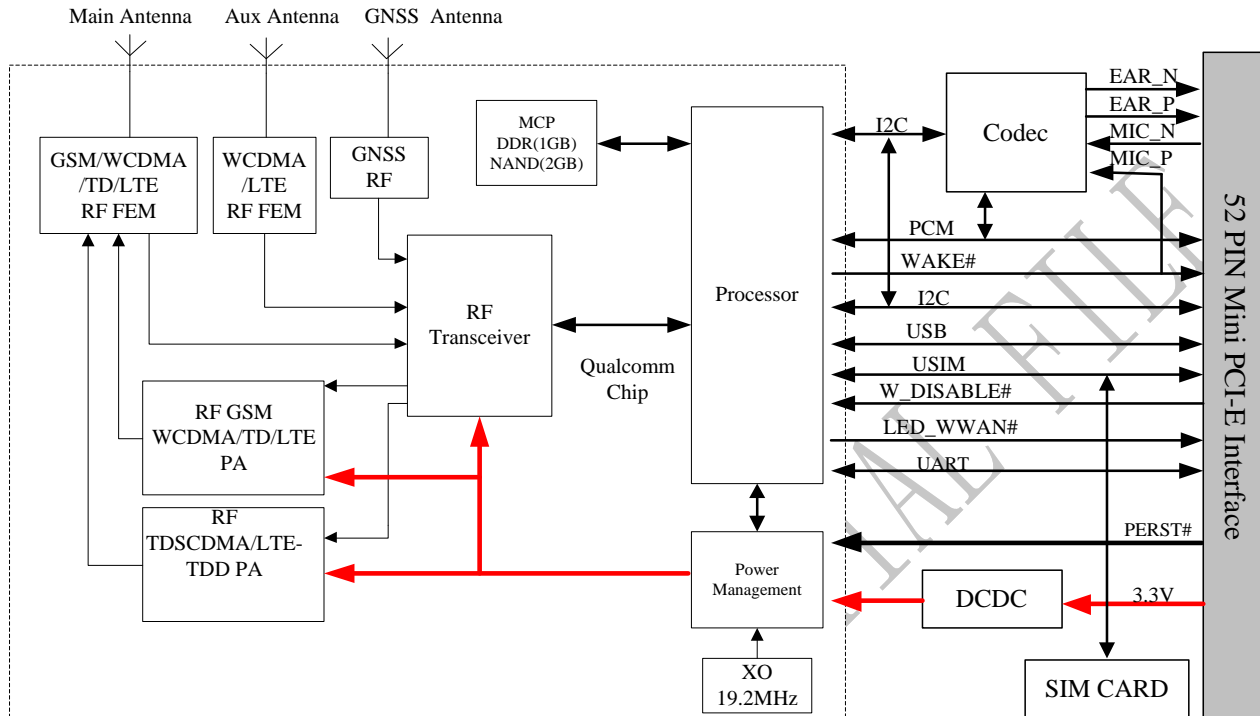

Figure 1: SIM7100-PCIE Block Diagram

### 1.4 Functional Overview

Table 2: SIM7100-PCIE Key Features

Feature	Implementation
Power supply	Single supply voltage 3.2V~3.6V
Radio frequency bands	Please refer to the table 1
Transmitting power	<p>GSM/GPRS:</p> <ul style="list-style-type: none"> <li>● Class 4 (2W): GSM850、EGSM900</li> <li>● Class 1 (1W): DCS1800、PCS1900</li> </ul> <p>EDGE:</p> <ul style="list-style-type: none"> <li>● Class E2 (0.5W): GSM850、EGSM900</li> <li>● Class E1 (0.4W): DCS1800、PCS1900</li> </ul> <p>UMTS:</p> <ul style="list-style-type: none"> <li>● Class 3 (0.25W): WCDMA,</li> <li>● Class 3 (0.25W): CDMA2000</li> <li>● Class 2 (0.25W): TD-SCDMA</li> </ul> <p>LTE:</p> <ul style="list-style-type: none"> <li>● Class 3 (0.2W): LTE</li> </ul>

Data Transmission Throughput	<ul style="list-style-type: none"> <li>● GPRS multi-slot class 12</li> <li>● EDGE multi-slot class 12</li> <li>● UMTS R99 speed: 384 kbps DL/UL</li> <li>● HSPA+: 5.76 Mbps(UL), 42 Mbps(DL)</li> <li>● TD-HSDPA/HSUPA: 2.2 Mbps(UL), 2.8 Mbps(DL)</li> <li>● CDMA EVDO:Rev-0,Rev-A, Rev-B</li> <li>● LTE Category 3 - 100 Mbps (DL)</li> <li>● LTE Category 3 - 50 Mbps (UL)</li> </ul>
Antenna	<ul style="list-style-type: none"> <li>● GSM/UMTS/LTE main antenna.</li> <li>● UMTS/LTE auxiliary antenna.</li> <li>● GPS/GLONASS antenna.</li> </ul>
GNSS	<ul style="list-style-type: none"> <li>● GNSS engine (GPS and GLONASS)</li> <li>● Protocol: NMEA</li> <li>● GPS supports MS/UE-based, MS/UE-assisted and hybrid modes with AFLT (CDMA), NMR (GSM), and MRL(UMTS, WCDMA, LTE), standalone and network-aware modes</li> <li>● GLONASS supports standalone mode</li> </ul>
SMS	<ul style="list-style-type: none"> <li>● MT, MO, CB, Text and PDU mode</li> <li>● SMS storage: USIM card or ME(default)</li> <li>● Transmission of SMS alternatively over CSD or GPRS.</li> </ul>
USIM interface	Support identity card: 1.8V/ 3V
USIM application toolkit	<ul style="list-style-type: none"> <li>● Support SAT class 3, GSM 11.14 Release 98</li> <li>● Support USAT</li> </ul>
Phonebook management	Support phonebook types: SM, FD, LD, RC, ON, MC
Audio feature	<ul style="list-style-type: none"> <li>● Support PCM interface.Only support PCM master mode and short frame sync, 16-bit linear data formats. Available only when audio codec chip is not mounted on PCIE board.</li> <li>● One analog signal output with 32Ω load resistance,50mW output power,and one analog input. Available only when audio codec chip is mounted on PCIE board.</li> </ul>
UART interface	<ul style="list-style-type: none"> <li>● A full modem serial port by default</li> <li>● Baud rate: 300bps to 4Mbps(default:115200bps)</li> <li>● Autobauding baud rate: 1200 bps to 115200bps</li> <li>● Can be used as the AT commands or data stream channel.</li> <li>● Support RTS/CTS hardware handshake and software ON/OFF flow control</li> <li>● Multiplex ability according to GSM 07.10 Multiplexer Protocol.</li> </ul>
USB	USB 2.0 specification-compliant as a peripheral
Firmware upgrade	<ul style="list-style-type: none"> <li>● Firmware upgrade over USB interface</li> <li>● FOTA</li> </ul>
Physical characteristics	Size: 50.80*31*5.35mm Weight:less than 12g
Temperature range	<ul style="list-style-type: none"> <li>● Normal operation temperature: -30 ℃ to +80 ℃</li> <li>● Extended operation temperature: -40 ℃ to +85 ℃*</li> <li>● Storage temperature -45 ℃ to +90 ℃</li> </ul>

*\*Note: Module is able to make and receive voice calls, data calls, SMS and make GPRS/WCDMA/HSPA+/LTE traffic in  $-40^{\circ}\text{C}$ ~ $+85^{\circ}\text{C}$ . The performance will reduce slightly from the 3GPP specifications if the temperature is outside of the normal operating temperature and still within the extreme operating temperature.*

SIMCOM CONFIDENTIAL FILE

## 2 Package Information

### 2.1 Pin Out Diagram

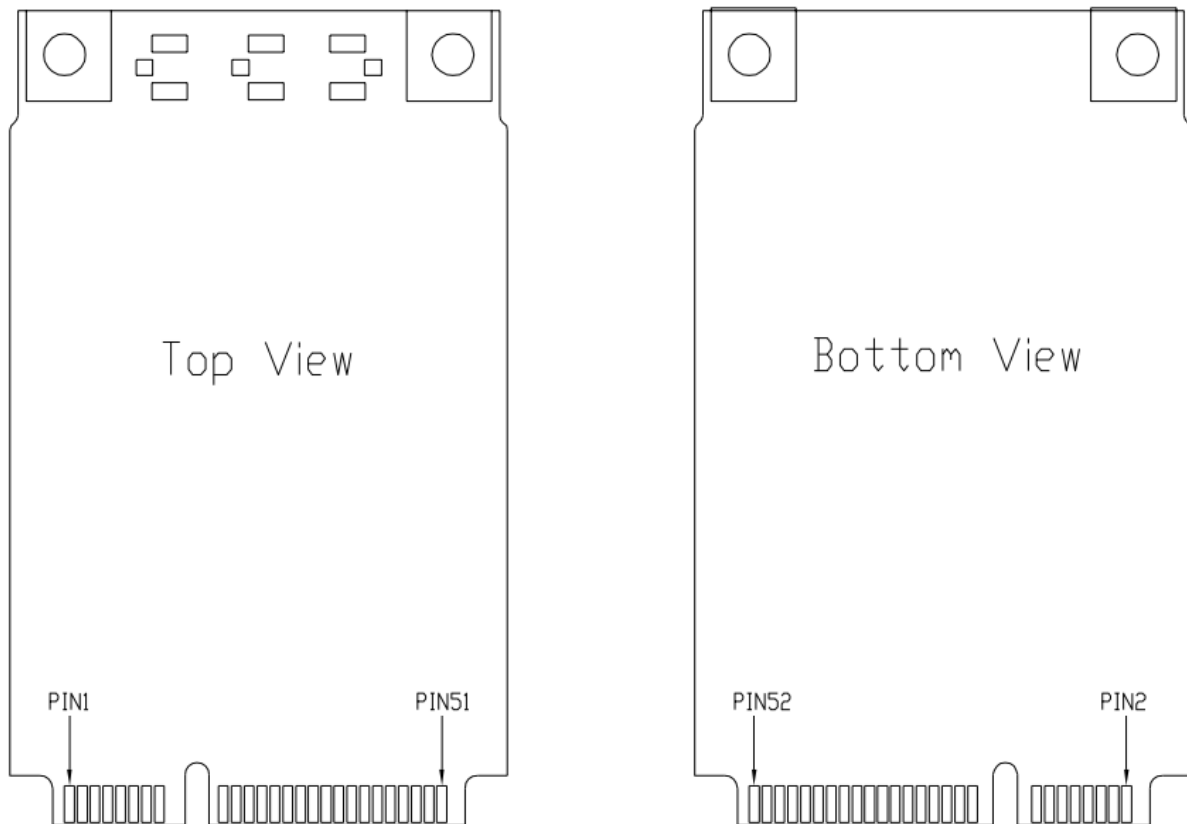

Figure 2: SIM7100-PCIE Pin Out Diagram

### 2.2 PCI Express Mini Card Connector Pin Description

Table 3: PCI Express Mini Card Connector Pin Description

Pin name	Pin number	I/O	Description	Comment
<b>Power supply</b>				
VCC	2,24,39,41,52	I	3.3V Power supply for module	-
GND	4,9,15,18,21, 26,27,29,34,3 5,37,40,43,50		Ground	-
<b>Reset</b>				
PERST#	22	I	Reset input (Active low)	If unused, keep open.
<b>USB 2.0</b>				
USB_DP	38	I/O	USB 2.0 high speed port for data transfer, voice call, debug and FW download, etc.	If unused, keep open.
USB_DN	36			

USIM card interface				
USIM_VDD	8	O	Power output for USIM card, its output Voltage depends on USIM card type automatically. Its output current is up to 50mA.	-
USIM_DATA	10	I/O	USIM Card data I/O, which has been pulled up via a 20KR resistor to USIM_VDD internally. Do not pull it up or down externally.	-
USIM_CLK	12	O	USIM clock	-
USIM_RST	14	O	USIM Reset	-
USIM_DET	16	I	USIM card detect	-
PCM interface				
PCM_CLK	45	O	PCM data bit clock.	If these pins are unused, keep open. The PCM interface can not be used, if Audio Codec chip is mounted on PCIE board.
PCM_OUT	47	O	PCM data output	
PCM_IN	49	I	PCM data input	
PCM_SYNC	51	O	PCM data frame sync signal.	
UART interface				
UART_CTS	11	I	Clear to Send	If unused, keep open
UART_RTS	13	O	Request to send	
UART_RXD	17	I	Receive Data	
UART_TXD	19	O	Transmit Data	
UART_RI	44	O	Ring Indicator	
UART_DTR	46	I	DTE get ready	
I2C interface				
SCL	30	O	I2C clock output	If unused, keep open
SDA	32	I/O	I2C data input/output	
others				
WAKE#/MICP	1	I/O	Default: Wake up host Optional: MIC positive input	If unused, keep open. If Analog audio is available, wake up function is invalid. If Analog audio is needed, please consult our sales staff, for more information .
MICN	3	I	Default: NC Optional: MIC negative input	
EARP	5	O	Default: NC Optional: Receiver positive output	
EARN	7	O	Default: NC	



### 3 Interface Application

#### 3.1 Power Supply

The recommended power supply voltage of SIM7100-PCIE is 3.3V.

**Table 4: Recommended 3.3V Power Supply Characteristics**

Symbol	Parameter	Min	Type	Max	Unit
$V_o$	Power supply voltage	3.2	3.3	3.6	V
$I_o$	Supply current capability	-	2000	-	mA

#### 3.2 PERST#

SIM7100-PCIE can be reset by pulling the PERST# pin down to ground.

The PERST# pin has been pulled up with a 40K $\Omega$  resistor to 1.8V internally, so there is no need to pull it up externally. It is strongly recommended to put a 100nF capacitor and an ESD protection diode close to the RESET pin. Please refer to the following figure for the recommended reference circuit.

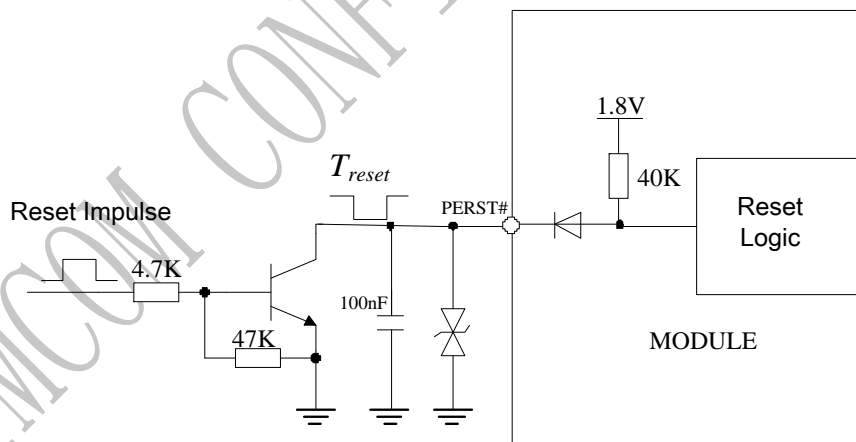

**Figure 4: PERST# Reference Circuit**

**Table 5: PERST# Pin Electronic Characteristic**

Symbol	Description	Min.	Typ.	Max.	Unit
$T_{reset}$	The active low level time impulse on PERST# pin to reset module	50	100	500	ms
$V_{IH}$	Input high level voltage	1.17	1.8	3.6	V
$V_{IL}$	Input low level voltage	-0.3	0	0.3	V



### 3.3 W\_DISABLE#

The W\_DISABLE# pin can be used to control SIM7100-PCIE to enter or exit the Flight mode. In Flight mode, the RF circuit is closed to prevent interference with other equipments and minimize current consumption.

**Table 6: W\_DISABLE# Pin Status**

W_DISABLE# status	Module operation
Input Low Level	Flight Mode: RF is closed.
Input High Level	Normal Mode: RF is working.

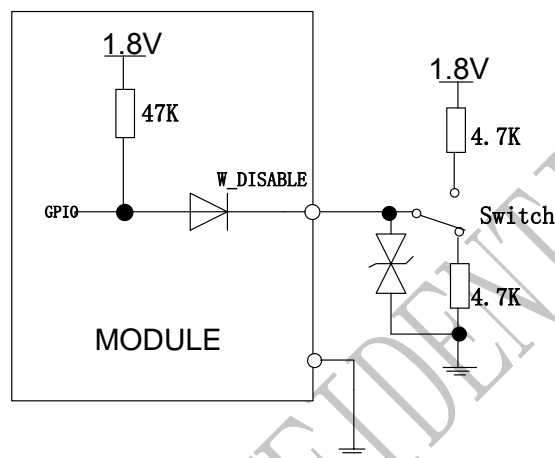

**Figure 5: W\_DISABLE# Reference Circuit**

**Table 7: W\_DISABLE# Pin Electrical Characteristic**

Symbol	Parameter	Min	Type	Max	Unit
V <sub>IH</sub>	High-level input voltage	1.17	1.8	3.6	V
V <sub>IL</sub>	Low-level input voltage	-0.3	0	0.3	V

### 3.4 LED\_WWAN#

The LED\_WWAN# pin can be used to drive a network status indication LED by default. Its status is listed in the following table.

**Table 8: Network Status Indication LED Status**

LED Status	Module Status
On	Searching Network/Call Connect

200ms On, 200ms Off	Data Transmit
800ms On, 800ms Off	Registered network
Off	Power off / Sleep

Reference circuit is recommended in the following figure:

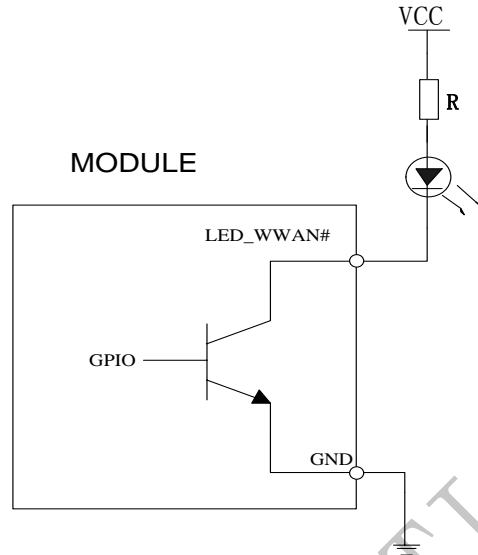

Figure 6: LED\_WWAN# Reference Circuit

### 3.5 WAKE#

The WAKE# pin can be used as an interrupt signal to host. Normally it will keep high logic level until certain condition such as receiving SMS, voice call (CSD, video) or URC reporting, then WAKE# will change to low logic level to inform the master (client PC). It will stay low until the master clears the interrupt event with AT command.

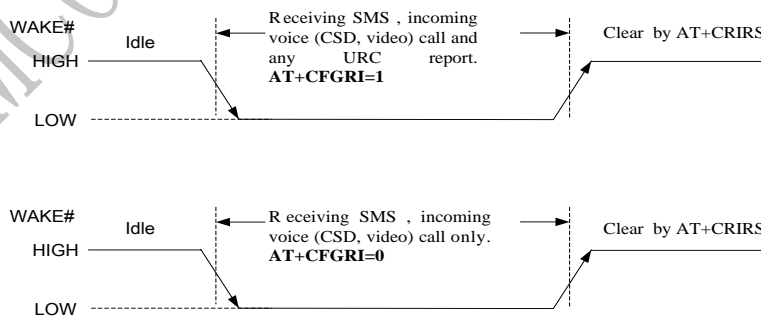
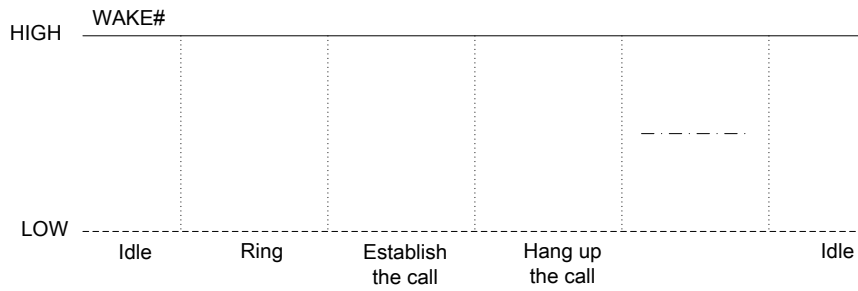

Figure 7: WAKE# behaviour

However, if the module is used as caller, the WAKE# will remain high. Please refer to the following figure.



**Figure 8: WAKE# behavior as a caller**

WAKE# Reference circuit is recommended in the following figure:

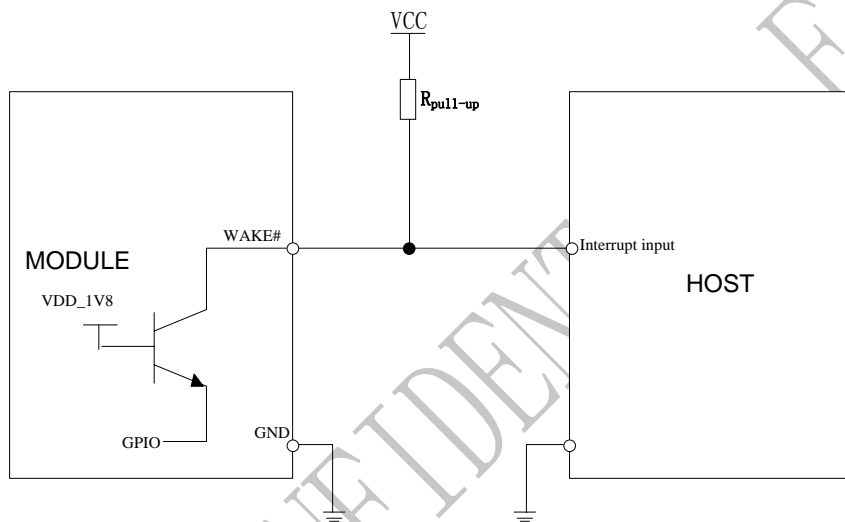

**Figure 9: WAKE# Reference Circuit**

*Note: If Analog audio is available, wake up function is invalid. Please consult our sales staff for more information.*

### 3.6 USB 2.0

SIM7100-PCIE is compliant with USB 2.0 specification. It supports full-speed and high-speed when acting as a peripheral device.

#### 3.6.1 USB Application Guide

SIM7100-PCIE can be used as a USB device. SIM7100-PCIE supports the USB suspend and resume mechanism which can reduce power consumption. If there is no data transmission on the USB bus, SIM7100-PCIE will enter suspend mode automatically, and will be resumed by some events such as voice call or receiving SMS, etc.

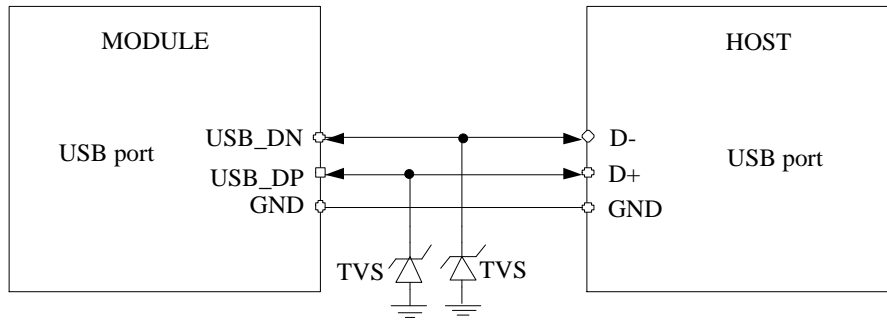
**Figure 10: USB Reference Circuit**

Because of the high bit rate on USB bus, please pay more attention to the influence of the junction capacitance of the ESD component on USB data lines. Typically, the capacitance should be less than 1pF. It is recommended to use an ESD protection component such as ESD9L5.0ST5G provided by On Semiconductor ([www.onsemi.com](http://www.onsemi.com)).

**Note :**

1. *The USB\_DN and USB\_DP nets must be traced by 90Ohm+/-10% differential impedance.*
2. *The USB VBUS of the module is connected to VBAT internally,so there is no need to connect externally.*
3. *The SIM7100-PCIE has two kinds of interface (UART and USB) to connect to host CPU. For example, on windows XP operating system, USB interface is mapped to 6 virtual ports: “SIMTECH HS-USB Modem 9001”, “SIMTECH HS-USB AT port 9001”, “SIMTECH HS-USB Audio 9001”, “SIMTECH HS-USB Diagnostics 9001”, “SIMTECH HS-USB NMEA 9001” and “SIMTECH Wireless HS-USB Ethernet Adapter 9001”.*

### 3.7 USIM Interface

USIM interface complies with the GSM Phase 1 specification and the new GSM Phase 2+ specification for FAST 64 kbps SIM card.Both 1.8V and 3.0V SIM card are supported.USIM interface is powered from an internal regulator in the module.

**Table 9: USIM Electronic characteristic in 1.8V mode (USIM\_VDD =1.8V)**

Symbol	Parameter	Min.	Typ.	Max.	Unit
USIM_VDD	LDO power output voltage	1.75	1.8	1.95	V
V <sub>IH</sub>	High-level input voltage	0.65 USIM_V DD	-	USIM_VDD +0.3	V
V <sub>IL</sub>	Low-level input voltage	-0.3	0	0.35 USIM_V DD	V
V <sub>OH</sub>	High-level output voltage	USIM_VDD -0.45	-	USIM_VDD	V
V <sub>OL</sub>	Low-level output voltage	0	0	0.45	V

**Table 10: USIM Electronic characteristic 3.0V mode (USIM\_VDD =2.95V)**

Symbol	Parameter	Min.	Typ.	Max.	Unit
USIM_VDD	LDO power output voltage	2.75	2.95	3.05	V
V <sub>IH</sub>	High-level input voltage	0.65*USIM_VDD	-	USIM_VDD +0.3	V
V <sub>IL</sub>	Low-level input voltage	-0.3	0	0.25 USIM_VDD	V
V <sub>OH</sub>	High-level output voltage	USIM_VDD -0.45	-	USIM_VDD	V
V <sub>OL</sub>	Low-level output voltage	0	0	0.45	V

### 3.7.1 USIM Application Guide

It is recommended to use an ESD protection component such as ST ([www.st.com](http://www.st.com)) ESDA6V1W5. Note that the SIM peripheral circuit should be close to the SIM card socket. For more details of AT commands about USIM, please refer to document [1].

The SIM\_DET pin is used for detection of the SIM card hot plug. User can select the 8-pin SIM card holder to implement SIM card detection function.

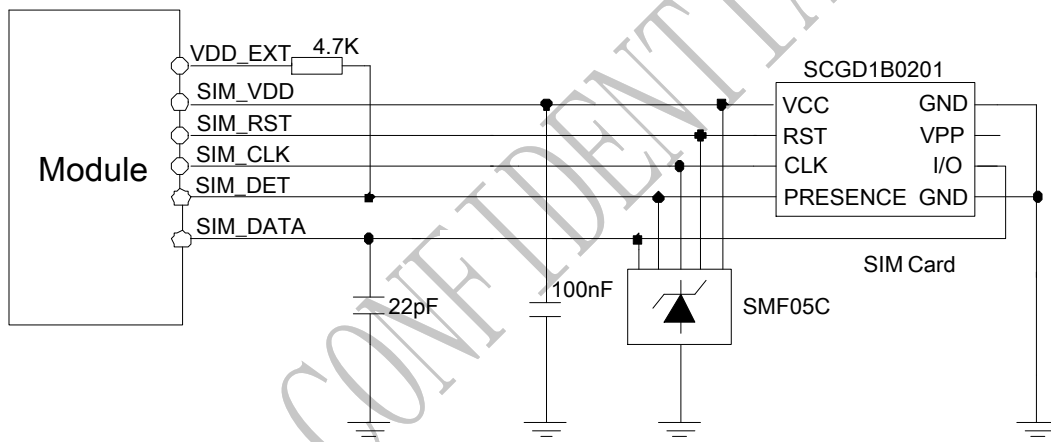

Figure 11: USIM interface reference circuit with detection function

If the SIM card detection function is not used, user can keep the SIM\_DET pin open. The reference circuit of 6-pin SIM card holder is illustrated in the following figure.

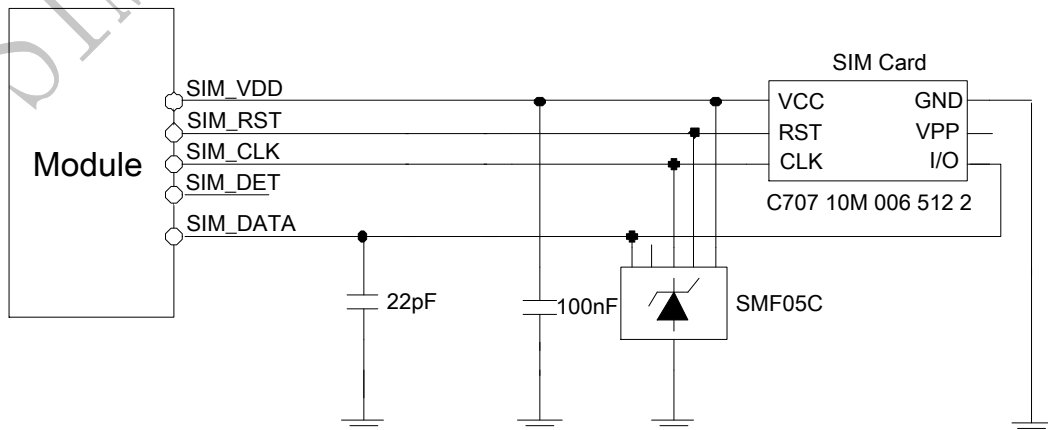

Figure 12: USIM interface reference circuit

*Note: USIM\_DATA has been pulled up with a 20KΩ resistor to USIM\_VDD in module. A 100nF capacitor on USIM\_VDD is used to reduce interference.*

### 3.8 UART Interface

SIM7100-PCIE provides one UART (universal asynchronous serial transmission) port. The module is as the DCE (Data Communication Equipment) and the client PC is as the DTE (Data Terminal Equipment). AT commands are entered and serial communication is performed through UART interface.

The application circuit is in the following figures.

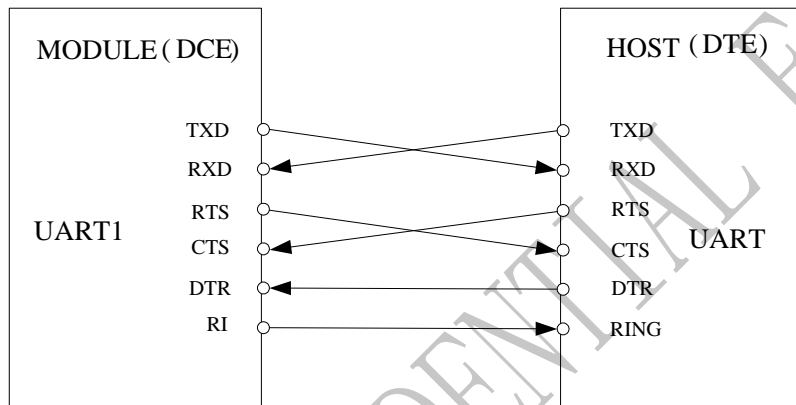

**Figure 13: UART Full modem**

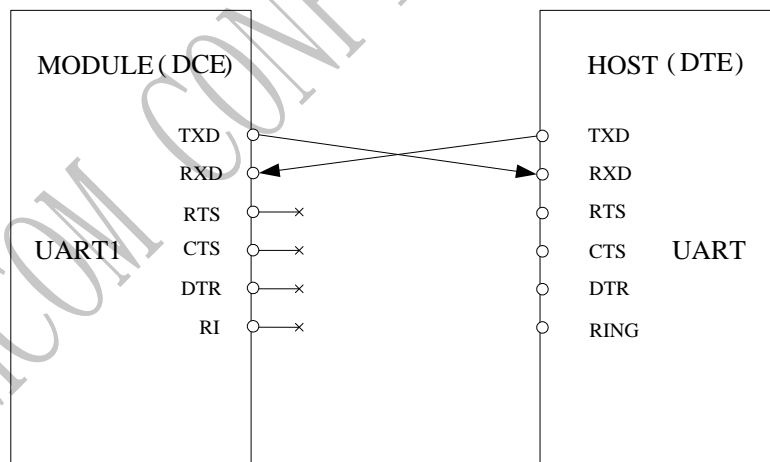

**Figure 14: UART Null modem**

**Table 11: UART Electrical Characteristic**

Symbol	Parameter	Min	Typ	Max	Unit
V <sub>IH</sub>	High-level input voltage	1.17	1.8	2.1	V
V <sub>IL</sub>	Low-level input voltage	-0.3	0	0.63	V
V <sub>OH</sub>	High-level output voltage	1.35	1.8	1.8	V

$V_{OL}$	Low-level output voltage	0	0	0.45	V
----------	--------------------------	---	---	------	---

The SIM7100-PCIE UART is 1.8V interface. A level shifter should be used if user's application is equipped with a 3.3V UART interface. The level shifter TXB0108RGYR provided by Texas Instruments is recommended. The reference design of the TXB0108RGYR is in the following figures.

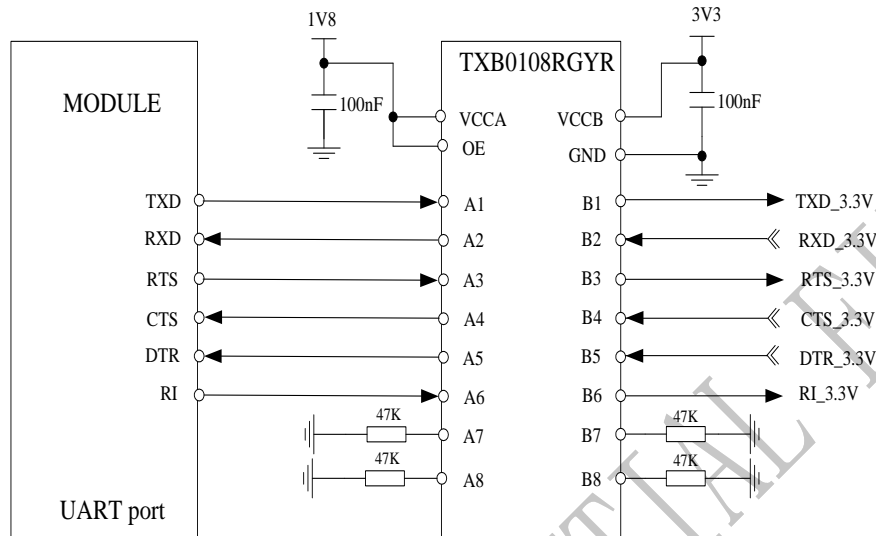

**Figure 15: Reference circuit of level shift**

To comply with RS-232-C protocol, the RS-232-C level shifter chip should be used to connect SIM7100-PCIE to the RS-232-C interface. In this connection, the TTL level and RS-232-C level are converted mutually. SIMCom recommends that user uses the SP3238ECA chip with a full modem. For more information please refers to the RS-232-C chip datasheet.

**Note:** SIM7100-PCIE supports the following baud rate: 300, 600, 1200, 2400, 4800, 9600, 19200, 38400, 57600, 115200, 230400, 460800, 921600, 3200000, 3686400, 4000000bps. Default baud rate is 115200bps.

### 3.9 I2C Interface

SIM7100-PCIE provides I2C interface compatible with I2C specification, version 2.1, with clock rate up to 400 kbps. Its operation voltage is 1.8V.

**Note:** Since the I2C is connected to the audio codec chip on board, the users should choose the I2C device whose address is not the same with the audio codec. If the audio codec chip is not mounted on board, users could ignore this.

#### 3.9.1 I2C Design Guide

The following figure shows the I2C bus reference design.

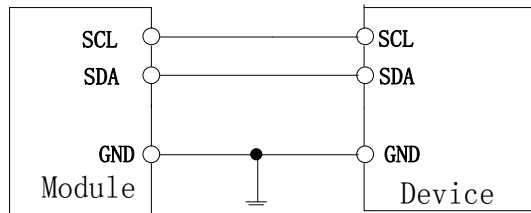

**Figure 16: I2C Reference Circuit**

*Note: SDA and SCL are pulled up to 1.8V via 10K resistors in module. So external pull up resistors are not needed in application circuit. For more details about I2C AT commands please refer to document [1].*

**Table 12: I2C Electrical Characteristic**

Symbol	Parameter	Min	Typ	Max	Unit
V <sub>IH</sub>	High-level input voltage	1.17	1.8	2.1	V
V <sub>IL</sub>	Low-level input voltage	-0.3	0	0.63	V
V <sub>OH</sub>	High-level output voltage	1.35	1.8	1.8	V
V <sub>OL</sub>	Low-level output voltage	0	0	0.45	V

### 3.10 PCM/Analog Audio Interface

#### 3.10.1 PCM Interface

SIM7100-PCIE provides hardware PCM interface for external codec. SIM7100-PCIE PCM interface can be used in short sync master mode only, and only supports 16 bits linear format.

*Note: The PCM interface can not be used if audio codec chip is mounted on PCIE board.*

**Table 13: PCM Specification**

Characteristics	Specification
Line Interface Format	Linear(Fixed)
Data length	16bits(Fixed)
PCM Clock/Sync Source	Master Mode(Fixed)
PCM Clock Rate	2048 KHz (Fixed)
PCM Sync Format	Short sync(Fixed)
Data Ordering	MSB

*Note: PCM interface can be control by AT command. For more details please refer to document [1]*

**Table 14: PCM DC Characteristics**



Symbol	Parameter	Min	Type	Max	Unit
V <sub>IH</sub>	High-level input voltage	1.17	1.8	2.1	V
V <sub>IL</sub>	Low-level input voltage	-0.3	0	0.63	V
V <sub>OH</sub>	High-level output voltage	1.35	1.8	1.8	V
V <sub>OL</sub>	Low-level output voltage	0	0	0.45	V

### 3.10.2 PCM timing

SIM7100-PCIE supports 2.048 MHz PCM data and sync timing for 16 bits linear format codec.

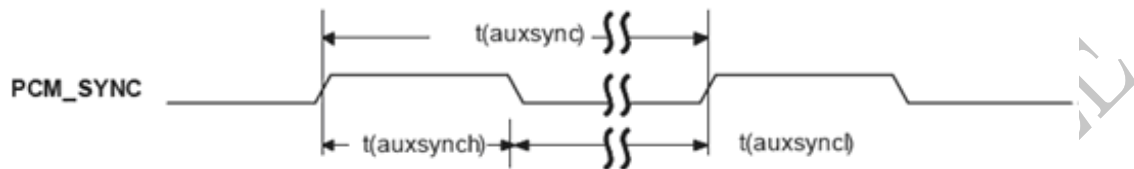

Figure 17: PCM\_SYNC timing

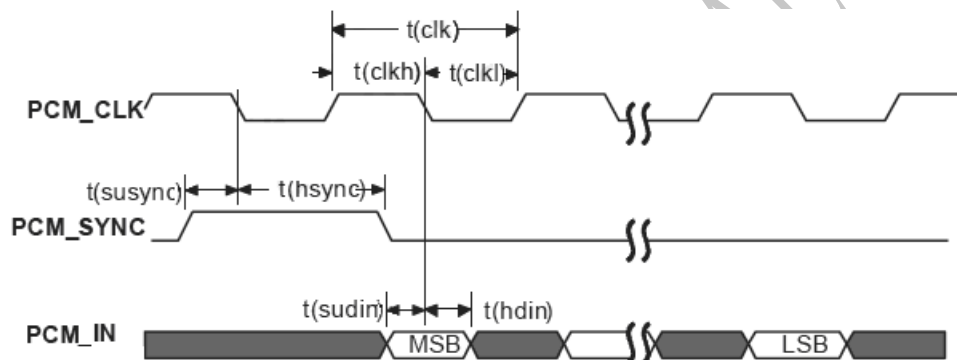

Figure 18: EXT CODEC to MODULE timing

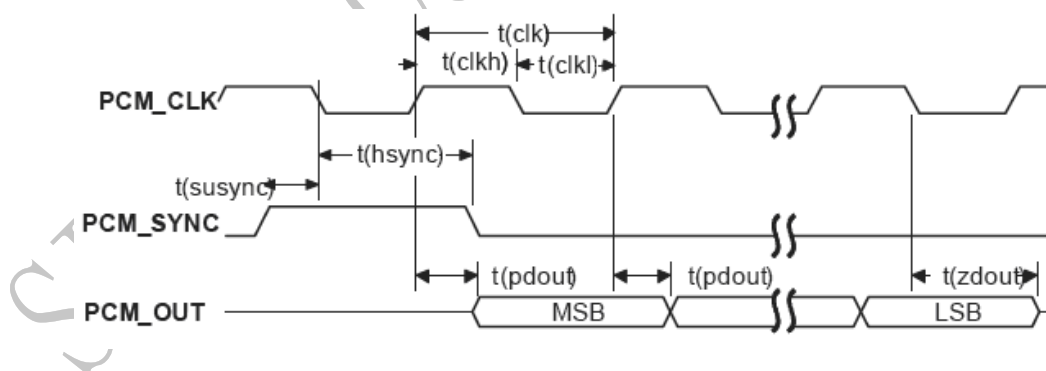

Figure 19: MODULE to EXT CODEC timing

Table 15: PCM Timing parameters

Parameter	Description	Min.	Typ.	Max.	Unit
T(sync)	PCM_SYNC cycle time	–	125	–	μs
T(synch)	PCM_SYNC high level time	–	488	–	ns
T(sync <sub>l</sub> )	PCM_SYNC low level time	–	124.5	–	μs
T(clk)	PCM_CLK cycle time	–	488	–	ns

T(clkh)	PCM_CLK high level time	–	244	–	ns
T(clkl)	PCM_CLK low level time	–	244	–	ns
T(susync)	PCM_SYNC setup time high before falling edge of PCM_CLK	–	122	–	ns
T(hsync)	PCM_SYNC hold time after falling edge of PCM_CLK	–	366	–	ns
T(sudin)	PCM_IN setup time before falling edge of PCM_CLK	60	–	–	ns
T(hdin)	PCM_IN hold time after falling edge of PCM_CLK	60	–	–	ns
T(pdout)	Delay from PCM_CLK rising to PCM_OUT valid	–	–	60	ns
T(zdout)	Delay from PCM_CLK falling to PCM_OUT HIGH-Z	–	–	60	ns

### 3.10.3 PCM Application Guide

The following figure shows the reference design of Audio codec chip WM8960 with SIM7100-PCIE.

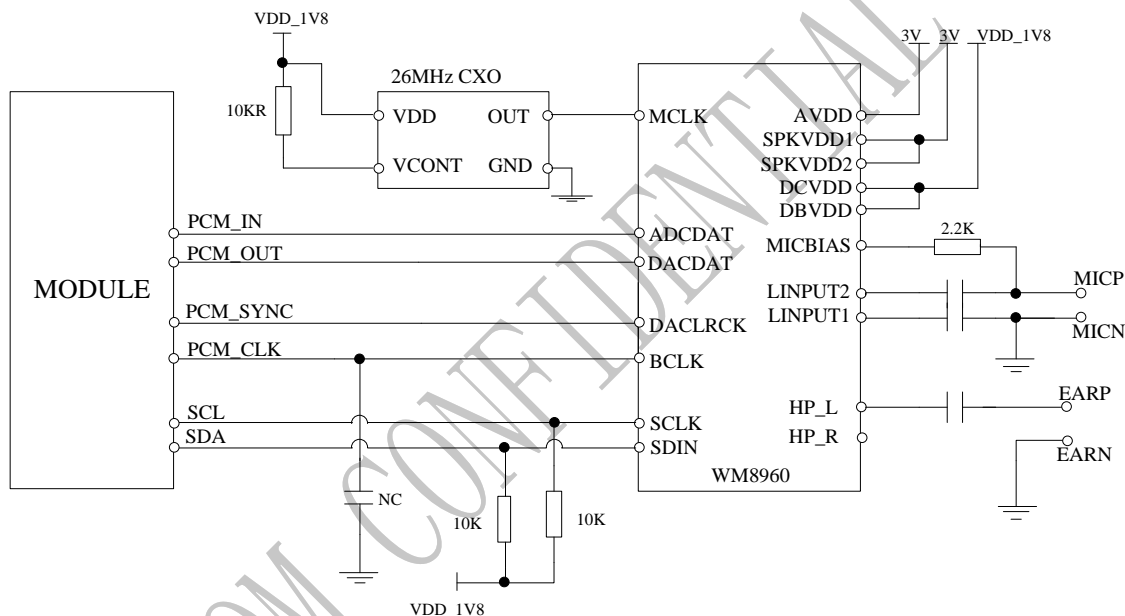

Figure 20: Audio Codec Reference Circuit

*Note: SIM7100-PCIE can transmit PCM data by USB port besides the PCM interface. For more details please refer to documents [1] and [23].*

### 3.10.4 Analog Audio Interface

When audio codec chip is mounted on the PCIE board, SIM7100-PCIE provides one analog signal output and one analog input. MICP/N is used as microphone input, EARP/N is used as audio output. Regarding audio parameters configuration, please refer to the ATC manual.

Table 16: MIC input characteristics

Parameter	Min	Typ	Max	Unit
Mic biasing voltage		1.80		V
Working Current			3	mA
External Microphone Load Resistance	1.2	2.2		K $\Omega$

**Table 17: Audio output characteristics**

Parameter	Min	Typ	Max	Unit
Load resistance	27	32	-	$\Omega$
Output power	-	50	-	mW

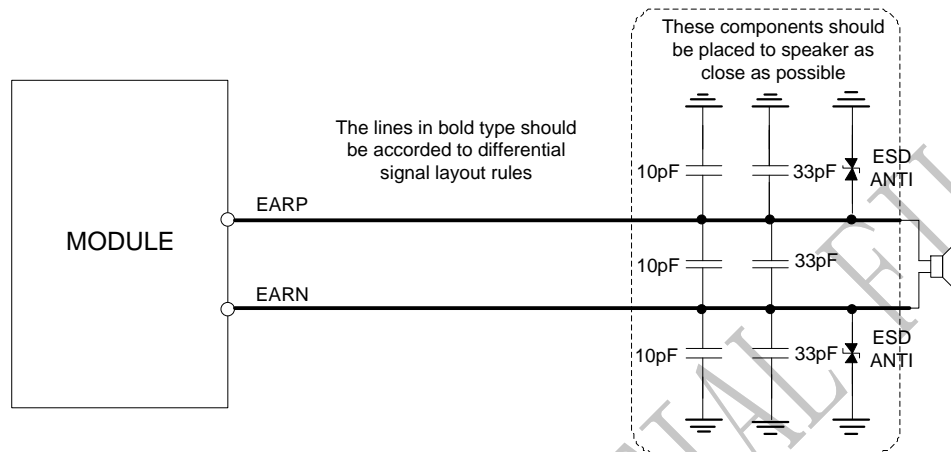
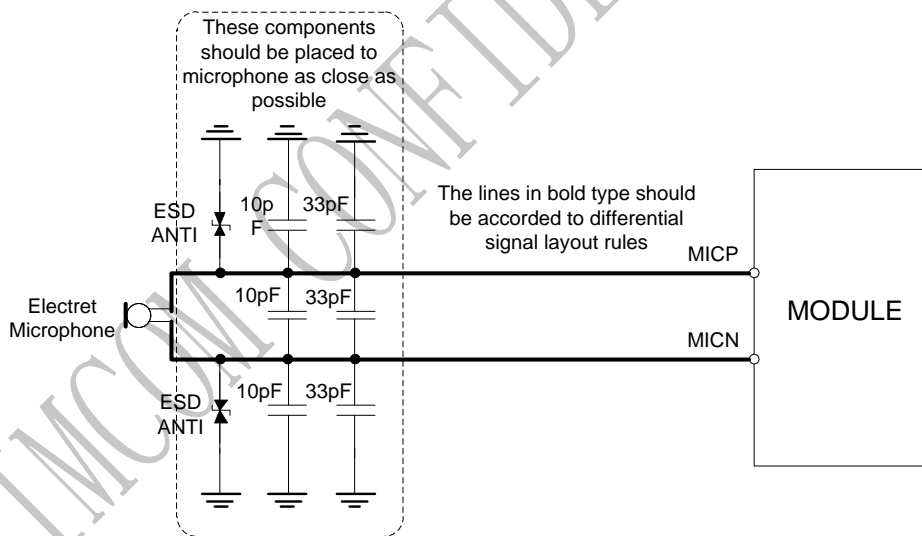
**Figure 21: Receiver interface configuration**

**Figure 22: Microphone interface configuration**

**Note:** SIM7100-PCIE has integrated MIC bias circuit. There is no need to pull the MICP and MICN up to the external power, just connect it to microphone. MICP and MICN must be differential lines.

Main audio parameters can be changed to satisfy users' requirement. User can adjust them through AT command according to their own electronic and mechanical design. For more details please refers to audio application document.

## 4 RF Specifications

### 4.1 GSM/WCDMA/TD-SCDMA/EVDO/LTE RF Specifications

**Table 18: Conducted transmission power**

Frequency	Power	Min.
E-GSM900	33dBm $\pm$ 2dB	5dBm $\pm$ 5dB
DCS1800	30dBm $\pm$ 2dB	0dBm $\pm$ 5dB
E-GSM900 (8-PSK)	27dBm $\pm$ 3dB	5dBm $\pm$ 5dB
DCS1800 (8-PSK)	26dBm +3/-4dB	0dBm $\pm$ 5dB
WCDMA B1	24dBm +1/-3dB	<-50dBm
WCDMA B2	24dBm +1/-3dB	<-50dBm
WCDMA B5	24dBm +1/-3dB	<-50dBm
WCDMA B6	24dBm +1/-3dB	<-50dBm
WCDMA B8	24dBm + 1/-3dB	<-50dBm
CDMA BC0	24dBm + 1/-3dB	<-50dBm
TDSCDMA 1900	24dBm + 1/-3dB	<-50dBm
TDSCDMA 2000	24dBm + 1/-3dB	<-50dBm
LTE-FDD B1	23dBm +/-2.7dB	<-40dBm
LTE-FDD B2	23dBm +/-2.7dB	<-40dBm
LTE-FDD B3	23dBm +/-2.7dB	<-40dBm
LTE-FDD B4	23dBm +/-2.7dB	<-40dBm
LTE-FDD B5	23dBm +/-2.7dB	<-40dBm
LTE-FDD B7	23dBm +/-2.7dB	<-40dBm
LTE-FDD B8	23dBm +/-2.7dB	<-40dBm
LTE-FDD B13	23dBm +/-2.7dB	<-40dBm
LTE-FDD B17	23dBm +/-2.7dB	<-40dBm
LTE-FDD B18	23dBm +/-2.7dB	<-40dBm
LTE-FDD B20	23dBm +/-2.7dB	<-40dBm
LTE-TDD B38	23dBm +/-2.7dB	<-40dBm
LTE-TDD B39	23dBm +/-2.7dB	<-40dBm
LTE-TDD B40	23dBm +/-2.7dB	<-40dBm
LTE-TDD B41	23dBm +/-2.7dB	<-40dBm

**Table 19: Operating frequencies**

Frequency	Receiving	Transmission
E-GSM900	925~960 MHz	880~915 MHz
DCS1800	1805~1880 MHz	1710~1785 MHz
WCDMA B1	2110~2170 MHz	1920~1980 MHz
WCDMA B2	1930~1990 MHz	1850~1910 MHz
WCDMA B5	869~894 MHz	824~849 MHz
WCDMA B6	875~885 MHz	830~840 MHz
WCDMA B8	925~960 MHz	880~915 MHz
TDSCDMA 1.9G	1880~1920 MHz	1880~1920 MHz
TDSCDMA 2G	2010~2025 MHz	2010~2025 MHz
CDMA BC0	869~894 MHz	824~849 MHz

The LTE Operating frequencies are shown in the following table 19.

Note: Operating frequencies of LTE TDD B41 for the SIM7100C is 100MHz BW, 2555~2655 MHz

GPS L1 BAND	1574.4 ~1576.44 MHz	-
GLONASS	1598 ~1606 MHz	-

**Table 20: E-UTRA operating bands**

E-UTRA Operating Band	Uplink (UL) operating band	Downlink (DL) operating band	Duplex Mode
	BS receive / UE transmit(UL)	BS transmit / UE receive(DL)	
1	1920 MHz~1980 MHz	2110 MHz~2170 MHz	FDD
2	1850 MHz~1910 MHz	1930 MHz~1990 MHz	FDD
3	1710 MHz~1785 MHz	1805 MHz~1880 MHz	FDD
4	1710 MHz~1755 MHz	2110 MHz~2155 MHz	FDD
5	824 MHz~849 MHz	869 MHz~894MHz	FDD
6 <sup>1</sup>	830 MHz~840 MHz	875 MHz~885 MHz	FDD
7	2500 MHz~2570 MHz	2620 MHz~2690 MHz	FDD
8	880 MHz~915 MHz	925 MHz~960 MHz	FDD
9	1749.9 MHz~1784.9 MHz	1844.9 MHz~1879.9 MHz	FDD
10	1710 MHz~1770 MHz	2110 MHz~2170 MHz	FDD
11	1427.9 MHz~1447.9 MHz	1475.9 MHz~1495.9 MHz	FDD
12	699 MHz~716 MHz	729 MHz~746 MHz	FDD
13	777 MHz~787 MHz	746 MHz~756 MHz	FDD
14	788 MHz~798 MHz	758 MHz~768 MHz	FDD
17	704 MHz~716 MHz	734 MHz~746 MHz	FDD
18	815 MHz~830 MHz	860 MHz~875 MHz	FDD
19	830 MHz~845 MHz	875 MHz~890 MHz	FDD
20	832 MHz~862 MHz	791 MHz~821 MHz	FDD
21	1447.9 MHz~1462.9 MHz	1495.9 MHz~1510.9 MHz	FDD
22	3410 MHz~3490 MHz	3510 MHz~3590 MHz	FDD
23	2000 MHz~2020 MHz	2180 MHz~2200 MHz	FDD
24	1626.5 MHz~1660.5 MHz	1525 MHz~1559 MHz	FDD
25	1850 MHz~1915 MHz	1930 MHz~1995 MHz	FDD
26	814 MHz~849 MHz	859 MHz~894 MHz	FDD
27	807 MHz~824 MHz	852 MHz~869 MHz	FDD
28	703 MHz~748 MHz	758 MHz~803 MHz	FDD
31	452.5 MHz~457.5 MHz	462.5 MHz~467.5 MHz	FDD
33	1900 MHz~1920 MHz	1900 MHz~1920 MHz	TDD
34	2010 MHz~2025 MHz	2010 MHz~2025 MHz	TDD
35	1850 MHz~1910 MHz	1850 MHz~1910 MHz	TDD
36	1930 MHz~1990 MHz	1930 MHz~1990 MHz	TDD
37	1910 MHz~1930 MHz	1910 MHz~1930 MHz	TDD
38	2570 MHz~2620 MHz	2570 MHz~2620 MHz	TDD

39	1880 MHz~1920 MHz	1880 MHz~1920 MHz	TDD
40	2300 MHz~2400 MHz	2300 MHz~2400 MHz	TDD
41	2496 MHz~2690 MHz	2496 MHz~2690 MHz	TDD
42	3400 MHz~3600 MHz	3400 MHz~3600 MHz	TDD
43	3600 MHz~3800 MHz	3600 MHz~3800 MHz	TDD
44	703 MHz~803 MHz	703 MHz~803 MHz	TDD

**NOTE:** For Band41, we support the subband form 2555MHz to 2655MHz.

**Table 21: Conducted receive sensitivity**

Frequency	Receive sensitivity(Typical)	Receive sensitivity(MAX)
E-GSM900	< -109dBm	3GPP
DCS1800	< -109dBm	3GPP
WCDMA 2100	< -110dBm	3GPP
WCDMA 1900	< -110dBm	3GPP
WCDMA 850	< -110dBm	3GPP
WCDMA 900	< -110dBm	3GPP
TDSCDMA 1900	< -110dBm	3GPP
TDSCDMA 2000	< -110dBm	3GPP
CDMA BC0	< -110dBm	3GPP
LTE FDD/TDD	See table 22.	3GPP

**Table 22: Reference sensitivity (QPSK)**

Channel bandwidth							
E-UTRA Band	1.4 MHz	3 MHz	5 MHz	10 MHz	15 MHz	20 MHz	Duplex Mode
1	-	-	-100	-97	-95.2	-94	FDD
2	-102.7	-99.7	-98	-95	-93.2	-92	FDD
3	-101.7	-98.7	-97	-94	-92.2	-91	FDD
4	-104.7	-101.7	-100	-97	-95.2	-94	FDD
5	-103.2	-100.2	-98	-95			FDD
6	-	-	-100	-97			FDD
7	-	-	-98	-95	-93.2	-92	FDD
8	-102.2	-99.2	-97	-94			FDD
9	-	-	-99	-96	-94.2	-93	FDD
10	-	-	-100	-97	-95.2	-94	FDD
11	-	-	-100	-97			FDD
12	-101.7	-98.7	-97	-94			FDD
13			-97	-94			FDD
14		-	-97	-94			FDD
17	-	-	-97	-94			FDD
18	-	-	-100	-97	-95.2	-	FDD

19	-	-	-100	-97	-95.2	-	FDD
20			-97	-94	-91.2	-90	FDD
21			-100	-97	-95.2		FDD
22			-97	-94	-92.2	-91	FDD
23	-104.7	-101.7	-100	-97			FDD
24			-100	-97			FDD
25	-101.2	-98.2	-96.5	-93.5	-91.7	-90.5	FDD
33	-	-	-100	-97	-95.2	-94	TDD
34	-	-	-100	-97	-95.2	-	TDD
35	-106.2	-102.2	-100	-97	-95.2	-94	TDD
36	-106.2	-102.2	-100	-97	-95.2	-94	TDD
37	-	-	-100	-97	-95.2	-94	TDD
38	-	-	-100	-97	-95.2	-94	TDD
39	-	-	-100	-97	-95.2	-94	TDD
40	-	-	-100	-97	-95.2	-94	TDD
41	-	-	-99	-96	-94.2	-93	TDD
42	-	-	-99	-96	-94.2	-93	TDD
43	-	-	-99	-96	-94.2	-93	TDD

SIMCOM CONFIDENTIAL

## 4.2 RF Antenna Connector

SIM7100-PCIE have 3 antenna connectors, one of which is the GSM/UMTS/LTE main antenna.connector, the others are UMTS/LTE auxiliary antenna connector and GPS/GLONASS antenna connector. Recommended antenna characteristics of SIM7100-PCIE are described by 2 following tables.

**Table 23: Recommended Passive Antenna Characteristics**

Passive	Recommended standard
Direction	omnidirectional
Gain	> -3dBi (Avg)
Input impedance	50 ohm
Efficiency	> 50 %
VSWR	< 2

**Table 24: Recommended Active Antenna Characteristics**

Band	Performance	
	TRP	TIS
GSM850	≅ 29dBm	≅ -104dBm
EGSM900	≅ 29dBm	≅ -104dBm
DCS1800	≅ 26dBm	≅ -104dBm
PCS1900	≅ 26dBm	≅ -104dBm
WCDMA B1	≅ 19dBm	≅ -104dBm
WCDMA B2	≅ 19dBm	≅ -104dBm
WCDMA B5	≅ 19dBm	≅ -104dBm
WCDMA B8	≅ 19dBm	≅ -104dBm
LTE B1	≅ 18dBm	≅ -92dBm
LTE B2	≅ 18dBm	≅ -90dBm
LTE B3	≅ 18dBm	≅ -89dBm
LTE B4	≅ 18dBm	≅ -92dBm
LTE B5	≅ 18dBm	≅ -90dBm
LTE B7	≅ 18dBm	≅ -90dBm
LTE B8	≅ 18dBm	≅ -89dBm
LTE B13	≅ 18dBm	≅ -89dBm
LTE B17	≅ 18dBm	≅ -89dBm
LTE B18	≅ 18dBm	≅ -92dBm
LTE B19	≅ 18dBm	≅ -92dBm
LTE B20	≅ 18dBm	≅ -89dBm
LTE B38	≅ 18dBm	≅ -92dBm
LTE B39	≅ 18dBm	≅ -92dBm
LTE B40	≅ 18dBm	≅ -92dBm



LTE B41

 $\cong 18\text{dBm}$ 
 $\cong -91\text{dBm}$ 

**NOTE: The above LTE only test 10MHZ bandwidth**

The RF connector in the module side is an ultra small surface mount coaxial connectors (Part Number: U.FL-R-SMT, vended by HRS). It has high performance with wide frequency range, surface mountable and reflows solderable. Following are parameters (Figure 23). Certainly user can visit <http://www.hirose-connectors.com/> for more information.

To get good RF performance in user's design, SIMCom suggests user to use the matching RF adapter cable which is also supplied by HRS (Part Number: U.FL-LP (V) -040), the following figure (Figure 24) is the dimensions of U.FL series RF adapter cable. User can contact SIMCom for more information.

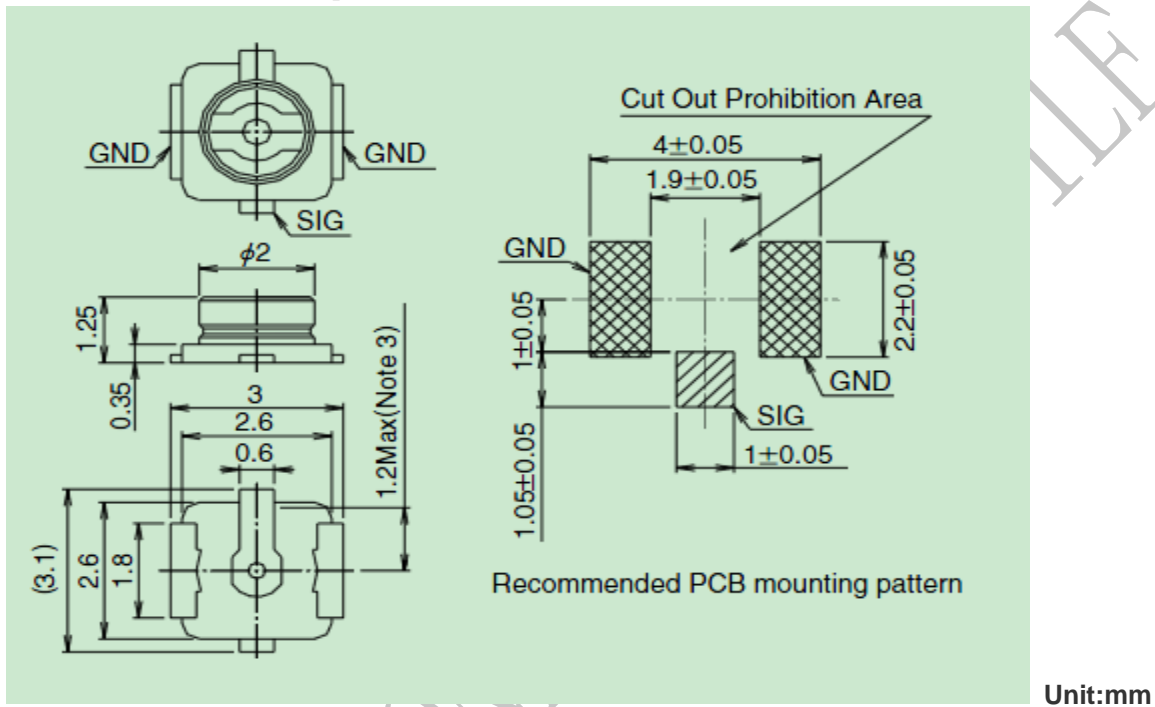

Figure 23: U.FL-R-SMT

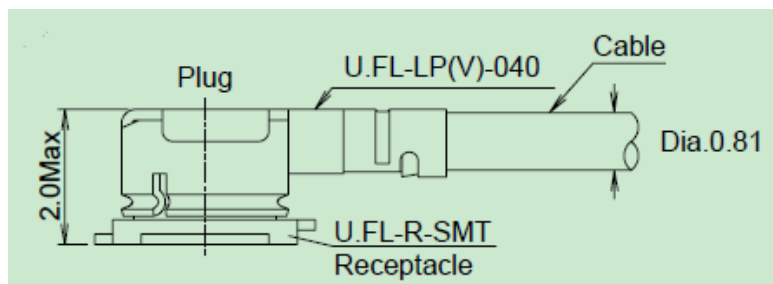
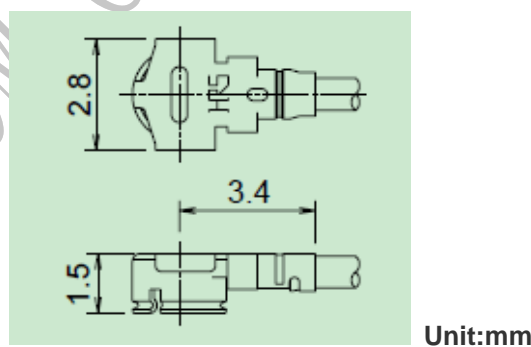

Figure 24: U.FL series RF adapter cable

### 4.3 GNSS (GPS and GLONASS)

SIM7100-PCIE merges GNSS (GPS/GLONASS) satellite and network information to provide a high-availability solution that offers industry-leading accuracy and performance. This solution performs well, even in very challenging environmental conditions where conventional GNSS receivers fail, and provides a platform to enable wireless operators to address both location-based services and emergency mandates.

#### 4.3.1 GNSS Technical specification

Tracking sensitivity	-159 dBm (GPS)	-158 dBm (GLONASS)
Cold-start sensitivity	-148 dBm	
Accuracy (Open Sky)	2.5m (CEP50)	
TTFF (Open Sky)	Hot start <1s	Cold start 35s
Receiver Type	16-channel, C/A Code	
	GPS L1 Frequency (1575.42±1.023MHz),	
	GLONASS: 1597.5~1605.8 MHz	
Update rate	Default 1 Hz	
GNSS data format	NMEA-0183	
GNSS Current consumption (WCDMA/GSM Sleep mode)	100mA (Total supply current)	
GNSS antenna	Passive/Active antenna	

There is no power supply on GPS antenna pad, if the antenna is active type, the power should be given by main board. It is suggested either the external LNA or active antenna used. It is not needed for both of them at the same time.

**Note: Performance will vary depending on the environment, antenna type and signal conditions and so on.**

#### 4.3.2 GNSS Operate Mode

SIM7100-PCIE supports both A-GPS and S-GPS, and then provides three operating modes: mobile-assisted mode, mobile-based mode and standalone mode. A-GPS includes mobile-assisted and mobile-based mode.

In mobile-assisted mode, when a request for position location is issued, available network information is provided to the location server (e.g. Cell-ID) and assistance is requested from the location server. The location server sends the assistance information to the handset. The handset/mobile unit measures the GNSS observables and provides the GNSS measurements along with available network data (that is appropriate for the given air interface technology) to the location server. The location server then calculates the position location and returns results to the requesting entity.

In mobile-based mode, the assistant data provided by the location server encompasses not only the information required to assist the handset in measuring the satellite signals, but also the information required to calculate the handset's position. Therefore, rather than provide the GNSS measurements and available network data back to the location server, the mobile calculates the location on the handset and passes the result to the requesting entity.

In standalone (autonomous) mode, the handset demodulates the data directly from the GNSS satellites. This mode has some reduced cold-start sensitivity, and a longer time to first fix as compared to the assisted modes. However, it requires no server interaction and works out of network coverage.

This combination of GNSS measurements and available network information provides:

- High-sensitivity solution that works in all terrains: Indoor, outdoor, urban, and rural
- High availability that is enabled by using both satellite and network information

Therefore, while network solutions typically perform poorly in rural areas and areas of poor cell geometry/density,

and while unassisted, GNSS-only solutions typically perform poorly indoors. The SIM7100-PCIE GNSS solution provides optimal time to fix, accuracy, sensitivity, availability, and reduced network utilization in both of these environments, depending on the given condition.

GNSS can be used by NMEA port. User can select NMEA as output through UART or USB. NMEA sentences are automatic and no command is provided. NMEA sentences include GSV, GGA, RMC, GSA, and VTG. Before using GNSS, user should configure SIM7100-PCIE in proper operating mode by AT command. Please refer to related document for details. SIM7100-PCIE can also get position location information through AT directly.

### 4.3.3 Application Guide

Users can adopt an active antenna or a passive antenna as GNSS signal receiver. In this document, all GNSS specification mentioned is from passive antenna. The following is the reference circuit.

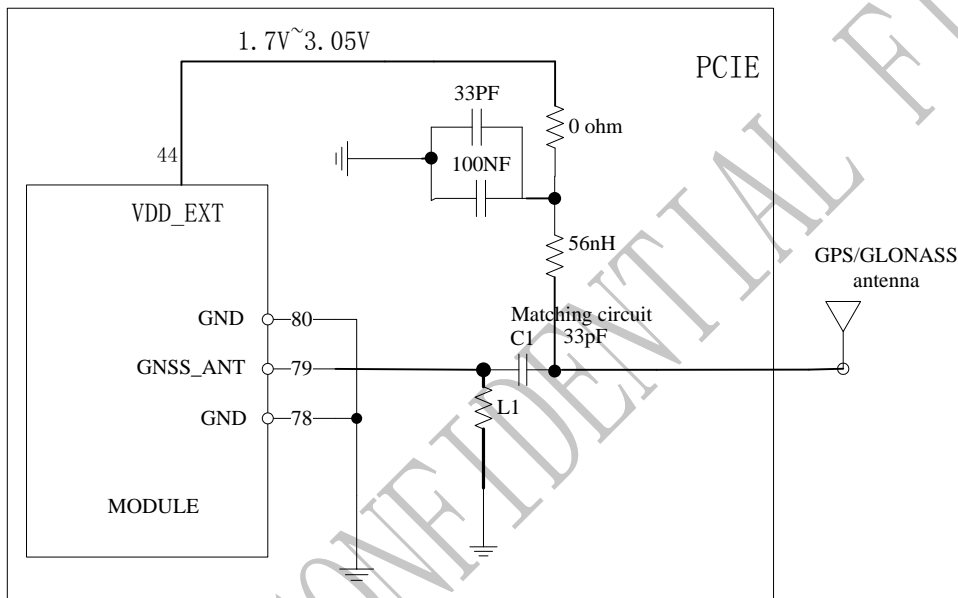

Figure 23 Active antenna circuit

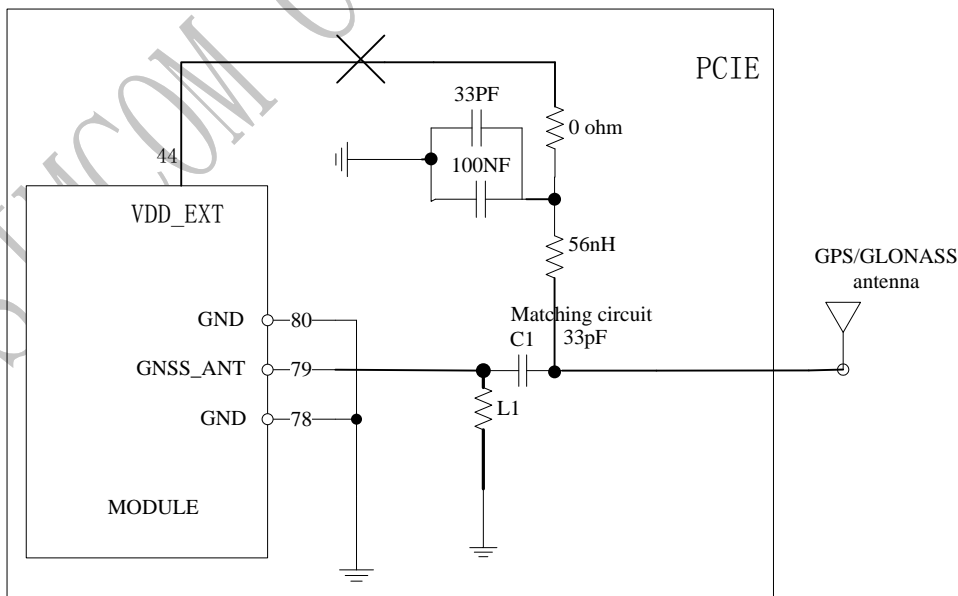

Figure 25: Passive antenna circuit (Default)

In above figures 24 is the default state, use the passive antenna and the VDD\_EXT do not output voltage. In above figures 23 use the active antenna, users need to open the VDD\_EXT by AT+CVAUXS=1, then VDD\_EXT output 2.95V. If users want to change the voltage of VDD\_EXT, use this AT command:

“AT+CVAUXV”. For example, if customer needs the output voltage value to be 1.8V, the At command is required to “AT+CVAUXV=1800000”. The output voltage range of VDD\_EXT is from 1.7V to 3.05V.

**Note:** For more details of AT commands about VDD\_EXT, please refer to document [1].

**Note:** GNSS is closed by default, it could be started by AT+CGPS. The AT command has two parameters, the first is on/off, and the second is GNSS mode. Default mode is standalone mode.

AGPS mode needs more support from the mobile telecommunication network. Please refer to document [24] for more details.

SIMCOM CONFIDENTIAL FILE

## 5 Electrical Specifications

### 5.1 Absolute Maximum Ratings

The absolute maximum ratings are described by the following table. Module may be damaged beyond these ratings.

**Table 25: Absolute maximum ratings**

Symbol	Parameter	Min	Type	Max	Unit
V <sub>CC</sub>	VCC input voltage	-0.3	-	4.5	V
V <sub>IO</sub>	Voltage at digital pins (1.8V digital I/O) *	-0.3	-	2.1	V

*\*Note: These parameters are for digital interface pins, such as PCM,I2C,UART.*

### 5.2 Recommended Operating Conditions

Please refer to the follow table for recommended operating conditions.

**Table 26: Operating Conditions**

Symbol	Parameter	Min	Type	Max	Unit
V <sub>CC</sub>	3.3V Input voltage	3.2	3.3	3.6	V
V <sub>IO</sub>	Voltage at digital pins (1.8V digital I/O)	0	1.8	1.95	V
T <sub>OPER</sub>	Operating temperature	-40	+25	+85	°C
T <sub>STG</sub>	Storage temperature	-45	+25	+90	°C

### 5.3 Operating Mode

#### 5.3.1 Operating Mode

The table below summarizes the various operating modes of SIM7100-PCIE.

**Table 27: Operating Mode**

Mode		Function
Normal operation	GSM/WCDMA /TD-SCDMA/EVDO/ LTE Sleep	In this case, the current consumption of module will be reduced to the minimal level and the module can still receive paging message and SMS.
	GSM/WCDMA /TD-SCDMA/EVDO/	Software is active. Module is registered to the network, and the module is ready to communicate.

LTE Idle	
GSM/WCDMA /TD-SCDMA/EVDO Talk	Connection between two subscribers is in progress. In this case, the power consumption depends on network settings such as DTX off/on, FR/EFR/HR, hopping sequences, antenna.
GPRS/EDGE/WCDMA/TD-SCDMA/EVDO/LTE Standby	Module is ready for data transmission, but no data is currently sent or received. In this case, power consumption depends on network settings.
GPRS/EDGE/WCDMA/TD-SCDMA/EVDO/LTE Data transmission	There is data transmission in progress. In this case, power consumption is related to network settings (e.g. power control level); uplink/downlink data rates, etc.
Minimum functionality mode	AT command “AT+CFUN” can be used to set the module to a minimum functionality mode without removing the power supply. In this mode, the RF part of the module will not work or the USIM card will not be accessible, or both RF part and USIM card will be closed, and the serial port and USB port are still accessible. The power consumption in this mode is lower than normal mode.
Power off	Module will go into power off mode by sending the AT command “AT+CPOF” or pull down the PWRKEY pin, normally. In this mode the power management unit shuts down the power supply, and software is not active. The serial port and USB are is not accessible.

### 5.3.2 Power saving mode

SIM7100-PCIE has two power saving modes: minimum functionality mode and sleep mode. in which module will achieve lower power consumption for power saving.

### 5.3.3 Sleep mode

In sleep mode, the current consumption of module will be reduced to the minimal level, and module can still receive paging message and SMS.

Several hardware and software conditions must be satisfied together in order to let SIM7100-PCIE enter into sleep mode:

1. UART condition
2. USB condition
3. Software condition

*Note: Before designing, pay attention to how to realize sleeping/waking function and refer to Document [22] for more details.*

### 5.3.4 Minimum functionality mode

Minimum functionality mode ceases a majority function of module, thus minimizing the power consumption. This mode is set by the AT command which provides a choice of the functionality levels.

- AT+CFUN=0: Minimum functionality
- AT+CFUN=1: Full functionality (Default)
- AT+CFUN=4: Disable RF function of the module (Flight mode)

If SIM7100-PCIE has been set to minimum functionality mode, the module will firstly enter sleep mode, then the RF function and SIM card function will be closed. In this case, the serial port is still accessible, but RF function or SIM card will be unavailable. When SIM7100-PCIE is in minimum functionality or flight mode, it can return to full functionality by the AT command “AT+CFUN=1”.

## 5.4 Current Consumption

The current consumption is listed in the table below.

**Table 28: Current Consumption(VCC =3.2V~3.6V)**

<b>GSM Sleep mode (without USB connection)</b>		
GSM/GPRS supply current (GNSS off)	Sleep mode @DRX=2	TBD
	Sleep mode @DRX=5	TBD
	Sleep mode @DRX=9	TBD
<b>GSM Sleep Mode (with USB suspended)</b>		
GSM/GPRS supply current (GNSS off)	Sleep mode @DRX=2	TBD
	Sleep mode @DRX=5	TBD
	Sleep mode @DRX=9	TBD
<b>UMTS Sleep/Idle Mode (without USB connection)</b>		
WCDMA supply current (GNSS off)	Sleep mode@DRX=9	TBD
	Sleep mode @DRX=8	TBD
	Sleep mode @DRX=6	TBD
	Idle mode @DRX=6	TBD
TD-SCDMA supply current (GNSS off)	Sleep mode@DRX=9	TBD
	Sleep mode @DRX=8	TBD
	Sleep mode @DRX=6	TBD
	Idle mode @DRX=6	TBD
EVDO supply current (GNSS off)	Sleep mode@DRX=9	TBD
	Sleep mode @DRX=8	TBD
	Sleep mode @DRX=6	TBD
	Idle mode @DRX=6	TBD
<b>UMTS Sleep/Idle Mode (with USB suspended)</b>		
WCDMA supply current (GNSS off)	Sleep mode @DRX=9	TBD
	Sleep mode @DRX=8	TBD
	Sleep mode @DRX=6	TBD
	Idle mode @DRX=6	TBD
TD-SCDMA supply current (GNSS off)	Sleep mode@DRX=9	TBD
	Sleep mode @DRX=8	TBD
	Sleep mode @DRX=6	TBD
	Idle mode @DRX=6	TBD
EVDO supply current (GNSS off)	Sleep mode@DRX=9	TBD
	Sleep mode @DRX=8	TBD
	Sleep mode @DRX=6	TBD
	Idle mode @DRX=6	TBD
<b>LTE Sleep mode (without USB connection)</b>		
LTE supply current (GNSS off)	Sleep mode @DRX=2	TBD
	Sleep mode @DRX=5	TBD
	Sleep mode @DRX=9	TBD
<b>LTE Sleep Mode (with USB suspended)</b>		
LTE supply current (GNSS off)	Sleep mode @DRX=2	TBD
	Sleep mode @DRX=5	TBD

	Sleep mode @DRX=9	TBD
<b>GSM Talk</b>		
GSM 900	@Power 33dBm	Typical TBD
DCS1800	@Power 30dBm	Typical TBD
<b>UMTS Talk</b>		
WCDMA B1	@Power 23dBm	Typical TBD
	@Power 21dBm	Typical TBD
	@Power 10dBm	Typical TBD
WCDMA B2	@Power 23dBm	Typical TBD
	@Power 21dBm	Typical TBD
	@Power 10dBm	Typical TBD
WCDMA B5	@Power 23dBm	Typical TBD
	@Power 21dBm	Typical TBD
	@Power 10dBm	Typical TBD
WCDMA B6	@Power 23dBm	Typical TBD
	@Power 21dBm	Typical TBD
	@Power 10dBm	Typical TBD
WCDMA B8	@Power 23dBm	Typical TBD
	@Power 21dBm	Typical TBD
	@Power 10dBm	Typical TBD
TD-SCDMA 1900	@Power 23dBm	Typical TBD
	@Power 21dBm	Typical TBD
	@Power 10dBm	Typical TBD
TD-SCDMA 2000	@Power 23dBm	Typical TBD
	@Power 21dBm	Typical TBD
	@Power 10dBm	Typical TBD
CDMA BC0	@Power 23dBm	Typical TBD
	@Power 21dBm	Typical TBD
	@Power 10dBm	Typical TBD
<b>DATA mode, GPRS ( 1 Rx,4 Tx ) CLASS 12</b>		
GSM 900	@Power 33dBm	Typical TBD
DCS1800	@Power 30dBm	Typical TBD
<b>DATA mode, GPRS ( 3Rx, 2 Tx ) CLASS 12</b>		
GSM 900	@Power 33dBm	Typical TBD
DCS1800	@Power 30dBm	Typical TBD
EDGE Data		
<b>DATA mode, EDGE( 1 Rx,4 Tx ) CLASS 12</b>		
GSM 900	@Power 27dBm	Typical TBD
DCS1800	@Power 24dBm	Typical TBD
<b>DATA mode, EDGE( 3Rx, 2 Tx ) CLASS 12</b>		
GSM 900	@Power 27dBm	Typical TBD
DCS1800	@Power 24dBm	Typical TBD
<b>HSDPA Data</b>		
WCDMA B1	@Power 23dBm CQI=22	Typical TBD
WCDMA B2	@Power 23dBm CQI=22	Typical TBD
WCDMA B5	@Power 23dBm CQI=22	Typical TBD
WCDMA B6	@Power 23dBm CQI=22	Typical TBD
WCDMA B8	@Power 23dBm CQI=22	Typical TBD
<b>TD-SCDMA Data</b>		
TDSCDMA 1900	@Power 23dBm	Typical TBD
	@Power 21dBm	Typical TBD



	@Power 10dBm	Typical TBD
TDSCDMA 2000	@Power 23dBm	Typical TBD
	@Power 21dBm	Typical TBD
	@Power 10dBm	Typical TBD
<b>EVDO Data</b>		
BC0	@Power 23dBm CQI=22	TBD
<b>LTE Data</b>		
LTE-FDD B1	TBD	
LTE-FDD B2	TBD	
LTE-FDD B3	TBD	
LTE-FDD B4	TBD	
LTE-FDD B5	TBD	
LTE-FDD B7	TBD	
LTE-FDD B8	TBD	
LTE-FDD B13	TBD	
LTE-FDD B17	TBD	
LTE-FDD B18	TBD	
LTE-FDD B20	TBD	
LTE-TDD B38	TBD	
LTE-TDD B39	TBD	
LTE-TDD B40	TBD	
LTE-TDD B41	TBD	

*Note: In the table above the current consumption value is the typical one of the module tested in the laboratory. In the mass production stage, there may be some difference.*

## 5.5 Electro-Static Discharge

SIM7100-PCIE is an ESD sensitive component, so more attention should be paid to the procedure of handling and packaging. The ESD test results are shown in the following table.

**Table 29: ESD characteristics (Temperature: 25°C, Humidity: 45 %)**

Pin	Contact discharge	Air discharge
VCC	±4KV	±8KV
GND	±4KV	±8KV
Antenna port	±4KV	±8KV
USB_DP,USB_DN	+/-3K	+/-6K
UART	+/-2K	+/-4K
Other PADs	+/-2K	+/-4K

## Appendix

### I. Coding Schemes and Maximum Net Data Rates over Air Interface

Table 30: Coding Schemes and Maximum Net Data Rates over Air Interface

Multislot definition(GPRS/EDGE)			
Slot class	DL slot number	UL slot number	Active slot number
1	1	1	2
2	2	1	3
3	2	2	3
4	3	1	4
5	2	2	4
6	3	2	4
7	3	3	4
8	4	1	5
9	3	2	5
10	4	2	5
11	4	3	5
12	4	4	5
GPRS coding scheme	Max data rata (4 slots)		Modulation type
CS 1 = 9.05 kb/s / time slot	36.2 kb/s		GMSK
CS 2 = 13.4 kb/s / time slot	53.6 kb/s		GMSK
CS 3 = 15.6 kb/s / time slot	62.4 kb/s		GMSK
CS 4 = 21.4 kb/s / time slot	85.6 kb/s		GMSK
EDGE coding scheme	Max data rata (4 slots)		Modulation type
MCS 1 = 8.8 kb/s/ time slot	35.2 kb/s		GMSK
MCS 2 = 11.2 kb/s/ time slot	44.8 kb/s		GMSK
MCS 3 = 14.8 kb/s/ time slot	59.2 kb/s		GMSK
MCS 4 = 17.6 kb/s/ time slot	70.4 kb/s		GMSK
MCS 5 = 22.4 kb/s/ time slot	89.6 kb/s		8PSK
MCS 6 = 29.6 kb/s/ time slot	118.4 kb/s		8PSK
MCS 7 = 44.8 kb/s/ time slot	179.2 kb/s		8PSK
MCS 8 = 54.4 kb/s/ time slot	217.6 kb/s		8PSK
MCS 9 = 59.2 kb/s/ time slot	236.8 kb/s		8PSK
HSDPA device category	Max data rate (peak)		Modulation type
Category 1	1.2Mbps		16QAM,QPSK
Category 2	1.2Mbps		16QAM,QPSK
Category 3	1.8Mbps		16QAM,QPSK

Category 4	1.8Mbps	16QAM,QPSK
Category 5	3.6Mbps	16QAM,QPSK
Category 6	3.6Mbps	16QAM,QPSK
Category 7	7.2Mbps	16QAM,QPSK
Category 8	7.2Mbps	16QAM,QPSK
Category 9	10.2Mbps	16QAM,QPSK
Category 10	14.4Mbps	16QAM,QPSK
Category 11	0.9Mbps	QPSK
Category 12	1.8Mbps	QPSK
Category 13	17.6Mbps	64QAM
Category 14	21.1Mbps	64QAM
Category 15	23.4Mbps	16QAM
Category 16	28Mbps	16QAM
Category 17	23.4Mbps	64QAM
Category 18	28Mbps	64QAM
Category 19	35.5Mbps	64QAM
Category 20	42Mbps	64QAM
Category 21	23.4Mbps	16QAM
Category 22	28Mbps	16QAM
Category 23	35.5Mbps	64QAM
Category 24	42.2Mbps	64QAM
<b>HSUPA device category</b>	<b>Max data rate (peak)</b>	<b>Modulation type</b>
Category 1	0.96Mbps	QPSK
Category 2	1.92Mbps	QPSK
Category 3	1.92Mbps	QPSK
Category 4	3.84Mbps	QPSK
Category 5	3.84Mbps	QPSK
Category 6	5.76Mbps	QPSK
<b>LTE-FDD device category (Downlink)</b>	<b>Max data rate (peak)</b>	<b>Modulation type</b>
Category 1	10Mbps	QPSK/16QAM/64QAM
Category 2	50Mbps	QPSK/16QAM/64QAM
Category 3	100Mbps	QPSK/16QAM/64QAM
Category 4	150Mbps	QPSK/16QAM/64QAM
<b>LTE-FDD device category (Uplink)</b>	<b>Max data rate (peak)</b>	<b>Modulation type</b>
Category 1	5Mbps	QPSK/16QAM
Category 2	25Mbps	QPSK/16QAM

Category 3	50Mbps	QPSK/16QAM
Category 4	50Mbps	QPSK/16QAM

SIMCOM CONFIDENTIAL FILE

## II. Related Documents

**Table 31: Related Documents**

SN	Title	Description
[1]	SIM7100_ATC_V0.xx	SIM7100_ATC_V0.xx
[2]	ITU-T Draft new recommendation V.25ter	Serial asynchronous automatic dialing and control
[3]	GSM 07.07	Digital cellular telecommunications (Phase 2+); AT command set for GSM Mobile Equipment (ME)
[4]	GSM 07.10	Support GSM 07.10 multiplexing protocol
[5]	GSM 07.05	Digital cellular telecommunications (Phase 2+); Use of Data Terminal Equipment – Data Circuit terminating Equipment (DTE – DCE) interface for Short Message Service (SMS) and Cell Broadcast Service (CBS)
[6]	GSM 11.14	Digital cellular telecommunications system (Phase 2+); Specification of the SIM Application Toolkit for the Subscriber Identity Module – Mobile Equipment (SIM – ME) interface
[7]	GSM 11.11	Digital cellular telecommunications system (Phase 2+); Specification of the Subscriber Identity Module – Mobile Equipment (SIM – ME) interface
[8]	GSM 03.38	Digital cellular telecommunications system (Phase 2+); Alphabets and language-specific information
[9]	GSM 11.10	Digital cellular telecommunications system (Phase 2); Mobile Station (MS) conformance specification; Part 1: Conformance specification
[10]	3GPP TS 51.010-1	Digital cellular telecommunications system (Release 5); Mobile Station (MS) conformance specification
[11]	3GPP TS 34.124	Electromagnetic Compatibility (EMC) for mobile terminals and ancillary equipment.
[12]	3GPP TS 34.121	Electromagnetic Compatibility (EMC) for mobile terminals and ancillary equipment.
[13]	3GPP TS 34.123-1	Technical Specification Group Radio Access Network; Terminal conformance specification; Radio transmission and reception (FDD)
[14]	3GPP TS 34.123-3	User Equipment (UE) conformance specification; Part 3: Abstract Test Suites.
[15]	EN 301 908-02 V2.2.1	Electromagnetic compatibility and Radio spectrum Matters (ERM); Base Stations (BS) and User Equipment (UE) for IMT-2000. Third Generation cellular networks; Part 2: Harmonized EN for IMT-2000, CDMA Direct Spread (UTRA FDD) (UE) covering essential requirements of article 3.2 of the R&TTE Directive
[16]	EN 301 489-24 V1.2.1	Electromagnetic compatibility and Radio Spectrum Matters (ERM); Electromagnetic Compatibility (EMC) standard for radio equipment and services; Part 24: Specific conditions for IMT-2000 CDMA Direct Spread (UTRA) for Mobile and portable (UE) radio and ancillary equipment
[17]	IEC/EN60950-1(2001)	Safety of information technology equipment (2000)
[18]	3GPP TS 51.010-1	Digital cellular telecommunications system (Release 5); Mobile Station (MS) conformance specification

[19]	GCF-CC V3.23.1	Global Certification Forum - Certification Criteria
[20]	2002/95/EC	Directive of the European Parliament and of the Council of 27 January 2003 on the restriction of the use of certain hazardous substances in electrical and electronic equipment (RoHS)
[21]	Module secondary-SMT-UGD-V1.xx	Module secondary SMT Guidelines
[22]	SIM7100_UART_Application_Note_V0.xx	This document describes how to use UART interface of SIMCom SIM7100 modules.
[23]	SIM7100_USB_AUDIO_Application_Note_V0.xx	USB AUDIO Application Note
[24]	SIM7100_GPS_Application_Note_V0.xx	SIM7100 GPS Application Note
[25]	SIM5360_TO_SIM7100 MIGRATION GUIDE_Application Note_V1.xx	SIM5360 toSIM7100 MIGRATION GUIDE Application Note
[26]	ANTENNA DESIGN GUIDELINES FOR DIVERSITY RECEIVER SYSTEM	ANTENNA DESIGN GUIDELINES FOR DIVERSITY RECEIVER SYSTEM

SIMCOM CONFIDENTIAL

### III. Terms and Abbreviations

**Table 32: Terms and Abbreviations**

Abbreviation	Description
ADC	Analog-to-Digital Converter
ARP	Antenna Reference Point
BER	Bit Error Rate
BTS	Base Transceiver Station
CS	Coding Scheme
CSD	Circuit Switched Data
CTS	Clear to Send
DAC	Digital-to-Analog Converter
DRX	Discontinuous Reception
DSP	Digital Signal Processor
DTE	Data Terminal Equipment (typically computer, terminal, printer)
DTR	Data Terminal Ready
DTX	Discontinuous Transmission
EFR	Enhanced Full Rate
EGSM	Enhanced GSM
EMC	Electromagnetic Compatibility
ESD	Electrostatic Discharge
ETS	European Telecommunication Standard
EVDO	Evolution Data Only
FCC	Federal Communications Commission (U.S.)
FD	SIM fix dialing phonebook
FDMA	Frequency Division Multiple Access
FR	Full Rate
GMSK	Gaussian Minimum Shift Keying
GPRS	General Packet Radio Service
GSM	Global Standard for Mobile Communications
HR	Half Rate
HSPA	High Speed Packet Access
I2C	Inter-Integrated Circuit
IMEI	International Mobile Equipment Identity
LTE	Long Term Evolution
MO	Mobile Originated
MS	Mobile Station (GSM engine), also referred to as TE
MT	Mobile Terminated
PAP	Password Authentication Protocol
PBCCH	Packet Switched Broadcast Control Channel
PCB	Printed Circuit Board
PCS	Personal Communication System, also referred to as GSM 1900
RF	Radio Frequency
RMS	Root Mean Square (value)
RTC	Real Time Clock
SIM	Subscriber Identification Module
SMS	Short Message Service
SPI	serial peripheral interface







SMPS	Switched-mode power supply
TDMA	Time Division Multiple Access
TE	Terminal Equipment, also referred to as DTE
TX	Transmit Direction
UART	Universal Asynchronous Receiver & Transmitter
VSWR	Voltage Standing Wave Ratio
SM	SIM phonebook
NC	Not connect
EDGE	Enhanced data rates for GSM evolution
HSDPA	High Speed Downlink Packet Access
HSUPA	High Speed Uplink Packet Access
ZIF	Zero intermediate frequency
WCDMA	Wideband Code Division Multiple Access
VCTCXO	Voltage control temperature-compensated crystal oscillator
USIM	Universal subscriber identity module
UMTS	Universal mobile telecommunications system
UART	Universal asynchronous receiver transmitter

SIMCOM CONFIDENTIAL



## IV. Safety Caution

**Table 33: Safety caution**

Marks	Requirements
	<p>When in a hospital or other health care facility, observe the restrictions about the use of mobiles. Switch the cellular terminal or mobile off, medical equipment may be sensitive to not operate normally for RF energy interference.</p>
	<p>Switch off the cellular terminal or mobile before boarding an aircraft. Make sure it is switched off. The operation of wireless appliances in an aircraft is forbidden to prevent interference with communication systems. Forget to think much of these instructions may lead to the flight safety or offend against local legal action, or both.</p>
	<p>Do not operate the cellular terminal or mobile in the presence of flammable gases or fumes. Switch off the cellular terminal when you are near petrol stations, fuel depots, chemical plants or where blasting operations are in progress. Operation of any electrical equipment in potentially explosive atmospheres can constitute a safety hazard.</p>
	<p>Your cellular terminal or mobile receives and transmits radio frequency energy while switched on. RF interference can occur if it is used close to TV sets, radios, computers or other electric equipment.</p>
	<p>Road safety comes first! Do not use a hand-held cellular terminal or mobile when driving a vehicle, unless it is securely mounted in a holder for hands free operation. Before making a call with a hand-held terminal or mobile, park the vehicle.</p>
	<p>GSM cellular terminals or mobiles operate over radio frequency signals and cellular networks and cannot be guaranteed to connect in all conditions, for example no mobile fee or a invalid SIM card. While you are in this condition and need emergent help, please remember using emergency calls. In order to make or receive calls, the cellular terminal or mobile must be switched on and in a service area with adequate cellular signal strength.</p> <p>Some networks do not allow for emergency call if certain network services or phone features are in use (e.g. lock functions, fixed dialing etc.). You may have to deactivate those features before you can make an emergency call.</p> <p>Also, some networks require that a valid SIM card be properly inserted in the cellular terminal or mobile.</p>

**Contact us:**

**Shanghai SIMCom Wireless Solutions Co.,Ltd.**

Add: SIM Technology Building, No.633, Jinzhong Road, Changning District, Shanghai P.R. China 200335

Tel: +86 21 3235 3300

Fax: +86 21 3235 3301

URL: [www.sim.com/wm](http://www.sim.com/wm)

SIMCOM CONFIDENTIAL FILE