

TPS6305x 开关电流为 1A、具备可调节软启动功能的单电感降压-升压转换器

1 特性

- 实时降压或升压，支持在降压模式和升压模式之间无缝转换
- 2.5V 至 5.5V 输入电压范围
- 0.5A 持续输出电流： $V_{IN} \geq 2.5V$ ， $V_{OUT} = 3.3V$
- 提供可调节输出电压和固定输出电压两种选项
- 升压模式下的效率高于 90%，而降压模式下的效率高于 95%
- 2.5MHz 典型开关频率
- 可调节平均输入电流限值
- 可调节软启动时间
- 器件静态电流 $< 60\mu A$
- 自动节能模式或强制脉宽调制 (PWM) 模式
- 关断期间负载断开
- 过热保护
- 采用 1.6mm x 1.2mm、12 引脚 WCSP 小型封装和 2.5mm x 2.5mm、12 引脚、HotRod™ QFN 封装

2 应用

- 蜂窝/智能电话
- 平板电脑
- 个人电脑和智能手机附件
- 电池供电类应用
- 智能电网/智能电表

3 说明

TPS6305x 系列器件是一款静态电流较低的高效降压/升压转换器，适用于输入电压高于或低于输出电压的应用。

在升压模式下，持续输出电流最高可达 500mA；在降压模式下，持续输出最高可达 1A。最大平均开关电流限制为 1A（典型值）。TPS6305x 系列器件在整个输入电压范围内针对输出电压进行稳压操作，可根据输入电压自动切换为降压或升压模式，从而在两种模式之间实现无缝转换。

该降压/升压转换器基于使用同步整流的固定频率 PWM 控制器，可实现最高效率。在负载电流较低的情况下，该转换器进入节能模式，从而在整个负载电流范围内保持高效率。

用户可以通过脉频调制 (PFM)/PWM 引脚选择自动 PFM/PWM 工作模式或强制 PWM 工作模式。在 PWM 模式下通常使用 2.5MHz 固定频率。使用一个外部电阻器分压器可对输出电压进行编程，或者在芯片上对输出电压进行内部固定。转换器可被禁用以大大减少电池消耗。在关断期间，负载从电池上断开。该器件采用 12 引脚芯片尺寸球状引脚栅格阵列 (DSBGA) 封装和 12 引脚 HotRod 封装。

器件信息⁽¹⁾

器件型号	封装	封装尺寸 (标称值)
TPS63050	DSBGA (12)	1.56mm x 1.16mm
TPS63051	VQFN (12)	2.50mm x 2.50mm

(1) 要了解所有可用封装，请见数据表末尾的可订购产品附录。

简化电路原理图 (WCSP)

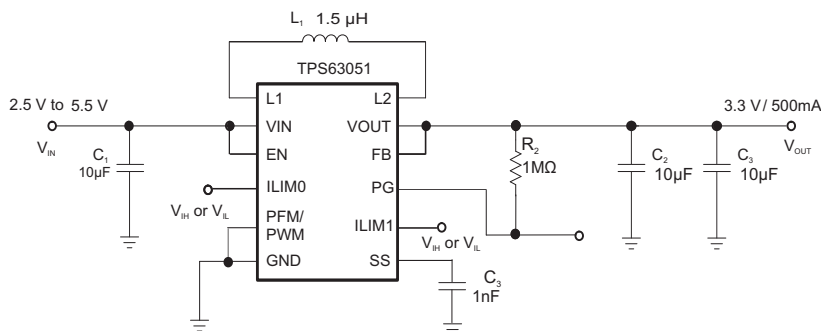

效率与输出电流间的关系

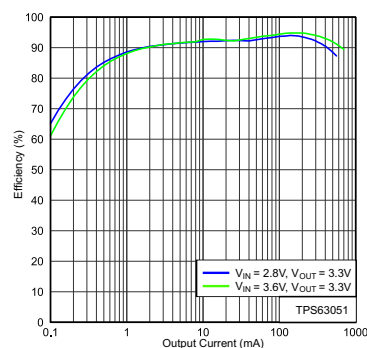

目录

1	特性	1	8.4	Device Functional Modes	11
2	应用	1	9	Application and Implementation	14
3	说明	1	9.1	Application Information	14
4	修订历史记录	2	9.2	Typical Application	14
5	Device Comparison Table	3	10	Power Supply Recommendations	21
6	Pin Configuration and Functions	3	11	Layout	21
7	Specifications	4	11.1	Layout Guidelines	21
7.1	Absolute Maximum Ratings	4	11.2	Layout Example (WCSP)	21
7.2	ESD Ratings	4	11.3	Layout Example (HotRod)	21
7.3	Recommended Operating Conditions	4	11.4	Thermal Considerations	22
7.4	Thermal Information	4	12	器件和文档支持	22
7.5	Electrical Characteristics	5	12.1	器件支持	22
7.6	Switching Characteristics	6	12.2	相关链接	22
7.7	Typical Characteristics	7	12.3	商标	22
8	Detailed Description	8	12.4	静电放电警告	22
8.1	Overview	8	12.5	Glossary	22
8.2	Functional Block Diagrams	8	13	机械、封装和可订购信息	22
8.3	Feature Description	10			

4 修订历史记录

注：之前版本的页码可能与当前版本有所不同。

Changes from Revision B (April 2015) to Revision C	Page
• 已添加 新封装选项至 特性	1
• 已添加 VQFN 封装至器件信息表	1
• Added HotRod Pin Configuration and Functions	3
• Added Parameter Measurement Circuit for HotRod package option	14

Changes from Revision A (February 2014) to Revision B	Page
• 已更改 说明 部分的第四段	1
• 已更改 图形图像	1
• Changed "Ordering Information" table to "Device Comparison Table"	3
• Changed "Handling Ratings" table to "ESD Rating" table and moved T_{stg} spec to the Absolute Maximum Ratings table....	4
• Moved some Typical Characteristics graphs to the Application Curves section	7

Changes from Original (July 2013) to Revision A	Page
• 已添加 器件信息表, ESD 额定值表, 特性 描述部分, 器件功能模式, 应用和实施部分, 电源相关建议部分, 布局部分, 器件和文档支持部分以及机械、封装和可订购信息部分	1
• 已添加 TPS63050 器件规范和 说明 至整篇数据手册	1
• Changed , PCB Layout	21
• Changed , PCB Layout	21

5 Device Comparison Table

PART NUMBER ⁽¹⁾	V _{OUT}
TPS63050	Adjustable
TPS63051	3.3 V

(1) For all available packages, see the orderable addendum at the end of the datasheet

6 Pin Configuration and Functions

**YFF Package
12-Pin DSBGA
(TOP VIEW)**

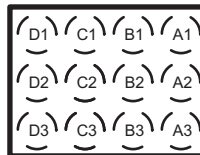

**RMW Package
12-Pin HotRod
(Top View)**

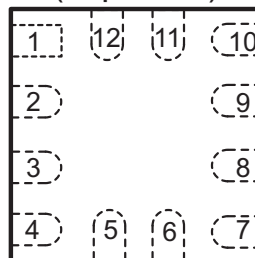

Pin Functions

TERMINAL			I/O	DESCRIPTION
NAME	WCSP	HotRod		
EN	A3	11	I	Enable input. (1 enabled, 0 disabled). It must not be left floating
FB	D2	5	I	Voltage feedback of adjustable versions, must be connected to V _{OUT} on fixed output voltage versions ¹
GND	B1	2,9		Ground for Power stage and Control stage
ILIM0	B2	10	I	Programmable inrush current limit input works together with I _{LIM1} . See table on page 1. It must not be left floating
ILIM1	B3	See ⁽¹⁾	I	Programmable inrush current limit input works together with I _{LIM0} . See 效率与输出电流间的关系 on page 1. Do not leave floating
L1	A1	1		Connection for Inductor
L2	C1	3		Connection for Inductor
PFM/PWM	C2	6	I	0 for PFM mode 1 for forced PWM mode. It must not be left floating
PG	C3	8	O	Power good open drain output
SS	D3	7	I	Adjustable Soft-Start. If left floating default soft-start time is set
VIN	A2	12	I	Supply voltage for power stage and control stage
VOUT	D1	4	O	Buck-boost converter output

(1) Only available with DSBGA package, for VQFN package ILIM1 is internally connected to voltage level > V_{IH}

7 Specifications

7.1 Absolute Maximum Ratings

 over junction temperature range (unless otherwise noted) ⁽¹⁾

		MIN	MAX	UNIT
Voltage ⁽²⁾	V _{IN} , L1, EN, V _{OUT} , FB, V _{IN} A, PFM/PWM	-0.3	7	V
	L2 ⁽³⁾	-0.3	7	
	L2 ⁽⁴⁾	-0.3	9.5	
Operating junction temperature, T _J		-40	150	°C
Operating ambient temperature, T _A		-40	85	°C
Storage temperature, T _{stg}		-65	150	°C

- (1) Stresses beyond those listed under *Absolute Maximum Ratings* may cause permanent damage to the device. These are stress ratings only, which do not imply functional operation of the device at these or any other conditions beyond those indicated under *Recommended Operating Conditions*. Exposure to absolute-maximum-rated conditions for extended periods may affect device reliability.
- (2) All voltage values are with respect to network ground pin.
- (3) DC voltage rating.
- (4) AC voltage rating.

7.2 ESD Ratings

		VALUE	UNIT
V _(ESD) Electrostatic discharge	Human-body model (HBM), per ANSI/ESDA/JEDEC JS-001 ⁽¹⁾	±1500	V
	Charged-device model (CDM), per JEDEC specification JESD22-C101 ⁽²⁾	±700	

- (1) JEDEC document JEP155 states that 500-V HBM allows safe manufacturing with a standard ESD control process.
- (2) JEDEC document JEP157 states that 250-V CDM allows safe manufacturing with a standard ESD control process.

7.3 Recommended Operating Conditions

See ⁽¹⁾		MIN	NOM	MAX	UNIT
V _{IN}	Input voltage	2.5		5.5	V
I _{OUT}	Output current			0.5	A
L	Inductance ⁽²⁾	1	1.5	2.2	μH
C _{OUT}	Output capacitance ⁽³⁾	10			μF
T _A	Operating ambient temperature	-40		85	°C
T _J	Operating virtual junction temperature	-40		125	°C

- (1) Refer to the Application Information section for further information
- (2) Effective inductance value at operating condition. The nominal value given matches a typical inductor to be chosen to meet the inductance required.
- (3) Due to the DC bias effect of ceramic capacitors, the effective capacitance is lower than the nominal value when a voltage is applied. This is why the capacitance is specified to allow the selection of the nominal capacitor required with the DC bias effect for this type of capacitor. The nominal value given matches a typical capacitor to be chosen to meet the minimum capacitance required.

7.4 Thermal Information

THERMAL METRIC ⁽¹⁾		TPS6305x		UNIT
		WCSP	RMW	
		12 PINS	12 PINS	
R _{θJA}	Junction-to-ambient thermal resistance	89.9	37.3	°C/W
R _{θJC(top)}	Junction-to-case (top) thermal resistance	0.7	30.4	°C/W
R _{θJB}	Junction-to-board thermal resistance	43.9	8.0	°C/W
Ψ _{JT}	Junction-to-top characterization parameter	2.9	0.4	°C/W
Ψ _{JB}	Junction-to-board characterization parameter	43.7	7.8	°C/W
R _{θJC(bot)}	Junction-to-case (bottom) thermal resistance	n/a	2.5	°C/W

- (1) For more information about traditional and new thermal metrics, see the *Semiconductor and IC Package Thermal Metrics* application report, [SPRA953](#).

7.5 Electrical Characteristics

 $V_{IN} = 3.6\text{ V}$, $T_J = -40^\circ\text{C}$ to 125°C , typical values are at $T_A = 25^\circ\text{C}$ (unless otherwise noted)

PARAMETER		TEST CONDITIONS	MIN	TYP	MAX	UNIT
SUPPLY						
V_{IN}	Input voltage range		2.5		5.5	V
V_{IN_Min}	Minimum input voltage to turn on in full load	$I_{OUT} = 500\text{ mA}$		2.7		V
I_{OUT}	Output current ⁽¹⁾	$I_{LIM0} = V_{IH}$, $I_{LIM1} = V_{IH}$		500		mA
I_Q	Quiescent current	V_{IN}		43	60	μA
		V_{OUT}			10	
I_{sd}	Shutdown current	$EN = 0\text{ V}$		0.1	1	μA
$UVLO_{TH}$	Undervoltage lockout threshold	V_{IN} falling	1.6	1.7	1.8	V
$UVLO_{hys}$	Undervoltage lockout hysteresis			200		mV
T_{SD}	Thermal shutdown	Temperature rising		140		$^\circ\text{C}$
$T_{SD(hys)}$	Thermal shutdown hysteresis			20		$^\circ\text{C}$
LOGIC SIGNALS EN, I_{LIM0}, I_{LIM1}						
V_{IH}	High level input voltage	$V_{IN} = 2.5\text{ V to }5.5\text{ V}$	1.2			V
V_{IL}	Low level voltage Input Voltage	$V_{IN} = 2.5\text{ V to }5.5\text{ V}$			0.3	V
I_{ikg}	Input leakage current	PFM / PWM, EN, I_{LIM0} , $I_{LIM1} = \text{GND or } V_{IN}$		0.01	0.1	μA
POWER GOOD						
V_{OL}	Low level voltage	$I_{sink} = 100\text{ }\mu\text{A}$			0.3	V
I_{PG}	PG sinking current	$V = 0.3\text{ V}$			0.1	mA
I_{ikg}	Input leakage current	$V_{PG} = 3.6\text{ V}$		0.01	0.1	μA
OUTPUT						
V_{OUT}	Output voltage range		2.5		5.5	V
V_{FB}	TPS63050 feedback regulation voltage			0.8		V
V_{FB}	TPS63050 feedback voltage accuracy	PWM mode	-1.1%		1.1%	
V_{FB}	TPS63050 feedback voltage accuracy ⁽²⁾	PFM mode	-1%		3%	
V_{OUT}	TPS63051 output voltage accuracy	PWM mode	3.27	3.3	3.34	V
V_{OUT}	TPS63051 output voltage accuracy ⁽²⁾	PFM mode	3.27	3.3	3.39	V
$I_{PWM \rightarrow PFM}$	Minimum output current to enter PFM mode	$V_{IN} = 3\text{ V}$; $V_{OUT} = 3.3\text{ V}$		150		mA
I_{FB}	TPS63050 feedback input bias current	$V_{FB} = 0.8\text{ V}$		10	100	nA
$R_{DS(on)}$	Input high-side FET on-resistance	$I_{SW} = 500\text{ mA}$		145		m Ω
	Output high-side FET on-resistance	$I_{SW} = 500\text{ mA}$		95		m Ω
	Input low-side FET on-resistance	$I_{SW} = 500\text{ mA}$		170		m Ω
	Output low-side FET on-resistance	$I_{SW} = 500\text{ mA}$		115		m Ω
I_{IN_MAX}	Input current-limit boost mode	$I_{LIM0} = V_{IH}$, $I_{LIM1} = V_{IH}$, $V_{IN} = 2.7\text{ V to }3\text{ V}$, $V_{OUT} = 3\text{ V}$	480		1240	mA
		$I_{LIM0} = V_{IH}$, $I_{LIM1} = V_{IH}$, $V_{IN} = 2.7\text{ V to }3.3\text{ V}$, $V_{OUT} = 3.3\text{ V}$,	550		1400	mA
		$I_{LIM0} = V_{IH}$, $I_{LIM1} = V_{IH}$, $V_{IN} = 2.7\text{ V to }4.5\text{ V}$, $V_{OUT} = 4.5\text{ V}$,	630		1950	mA

(1) For minimum and maximum output current in a specific working point see [Figure 1](#) and [Figure 2](#); and [Equation 1](#) through [Equation 4](#).

(2) Conditions: $f = 2.5\text{ MHz}$, $L = 1.5\text{ }\mu\text{H}$, $C_{OUT} = 10\text{ }\mu\text{F}$

Electrical Characteristics (continued)

 $V_{IN} = 3.6\text{ V}$, $T_J = -40^\circ\text{C}$ to 125°C , typical values are at $T_A = 25^\circ\text{C}$ (unless otherwise noted)

PARAMETER		TEST CONDITIONS	MIN	TYP	MAX	UNIT
I_{SS_IN}	Programmable inrush current limit ⁽³⁾	$I_{LIM0} = V_{IL}$, $I_{LIM1} = V_{IL}$, $V_{IN} = 3.0\text{ V}$, $V_{OUT} = 3.3\text{ V}$, (Available for DPGA only)	0.4× I_{IN_MAX}			mA
		$I_{LIM0} = V_{IH}$, $I_{LIM1} = V_{IL}$, $V_{IN} = 3.0\text{ V}$, $V_{OUT} = 3.3\text{ V}$, (Available for DPGA only)	0.5× I_{IN_MAX}			
		$I_{LIM0} = V_{IL}$, $I_{LIM1} = V_{IH}$, $V_{IN} = 3.0\text{ V}$, $V_{OUT} = 3.3\text{ V}$	0.65× I_{IN_MAX}			
		$I_{LIM0} = V_{IH}$, $I_{LIM1} = V_{IH}$, $V_{IN} = 3.0\text{ V}$, $V_{OUT} = 3.3\text{ V}$	I_{IN_MAX}			
I_{SS}	Soft-start current TPS63051		1			μA
I_{SS}	Soft-start current TPS63050		3.2			μA
	Line regulation	$V_{IN} = 2.5\text{ V}$ to 5.5 V , $I_{OUT} = 500\text{ mA}$, PWM mode	0.963			mV/V
	Load regulation	$V_{IN} = 3.6\text{ V}$, $I_{OUT} = 0\text{ mA}$ to 500 mA , PWM mode	4			mV/A

(3) For variation of this parameter with Input voltage see [Figure 3](#).

7.6 Switching Characteristics

 $V_{IN} = 3.6\text{ V}$, $T_J = -40^\circ\text{C}$ to 125°C , typical values are at $T_A = 25^\circ\text{C}$ (unless otherwise noted)

PARAMETER		TEST CONDITIONS	MIN	TYP	MAX	UNIT
OUTPUT						
f_s	Switching frequency		2.5			MHz
t_{SS}	Softstart time	$V_{OUT} = EN = \text{low to high}$, SS = floating, Buck mode $V_{IN} = 3.6\text{ V}$, $V_{OUT} = 3.3\text{ V}$, $I_{OUT} = 500\text{ mA}$ ⁽¹⁾	280			μs
		$V_{OUT} = EN = \text{low to high}$, SS = floating, Boost mode $V_{IN} = 2.5\text{ V}$, $V_{OUT} = 3.3\text{ V}$, $I_{OUT} = 500\text{ mA}$ ⁽¹⁾	600			
t_d	Start up delay	Time from when EN = high to when device starts switching	100			μs

(1) For variation of this parameter with Input voltage see [Figure 3](#).

7.7 Typical Characteristics

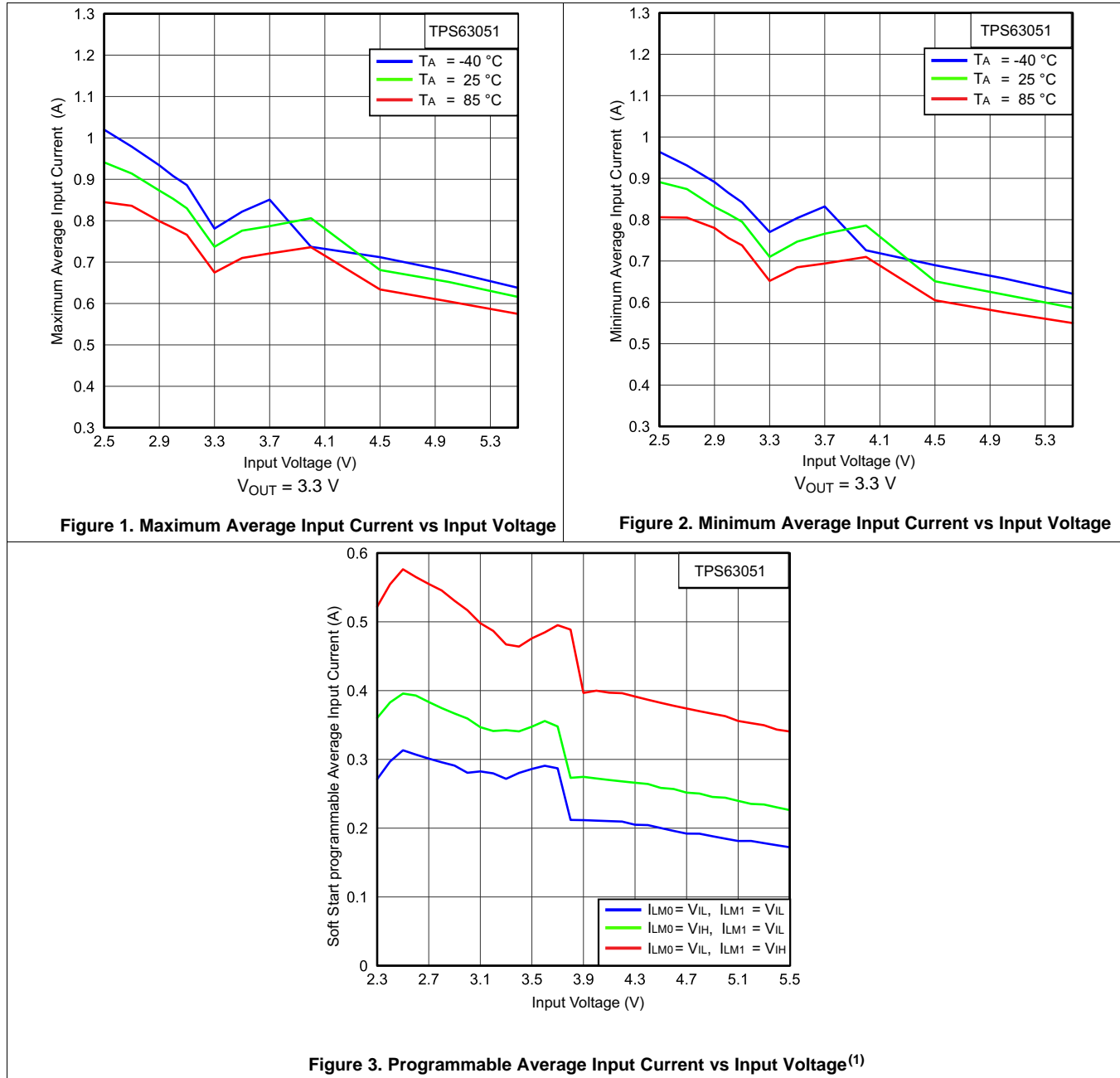

(1) All options only available with the DSBGA package. For VQFN package I_{LM1} is internally connected to voltage level $> V_{IH}$

8 Detailed Description

8.1 Overview

The TPS6305x devices use 4 internal N-channel MOSFETs to maintain synchronous power conversion at all possible operating conditions. This enables the device to keep high efficiency over the complete input voltage and output power range. To regulate the output voltage at all possible input voltage conditions, the device automatically switches from buck operation to boost operation and back as required by the configuration. It always uses one active switch, one rectifying switch, one switch held on, and one switch held off. Therefore, it operates as a buck converter when the input voltage is higher than the output voltage, and as a boost converter when the input voltage is lower than the output voltage. There is no mode of operation in which all 4 switches are switching at the same time. Keeping one switch on and one switch off eliminates their switching losses. The RMS current through the switches and the inductor is kept at a minimum, to minimize switching and conduction losses. Controlling the switches this way allows the converter to always keep higher efficiency.

The device provides a seamless transition from buck to boost or from boost to buck operation.

8.2 Functional Block Diagrams

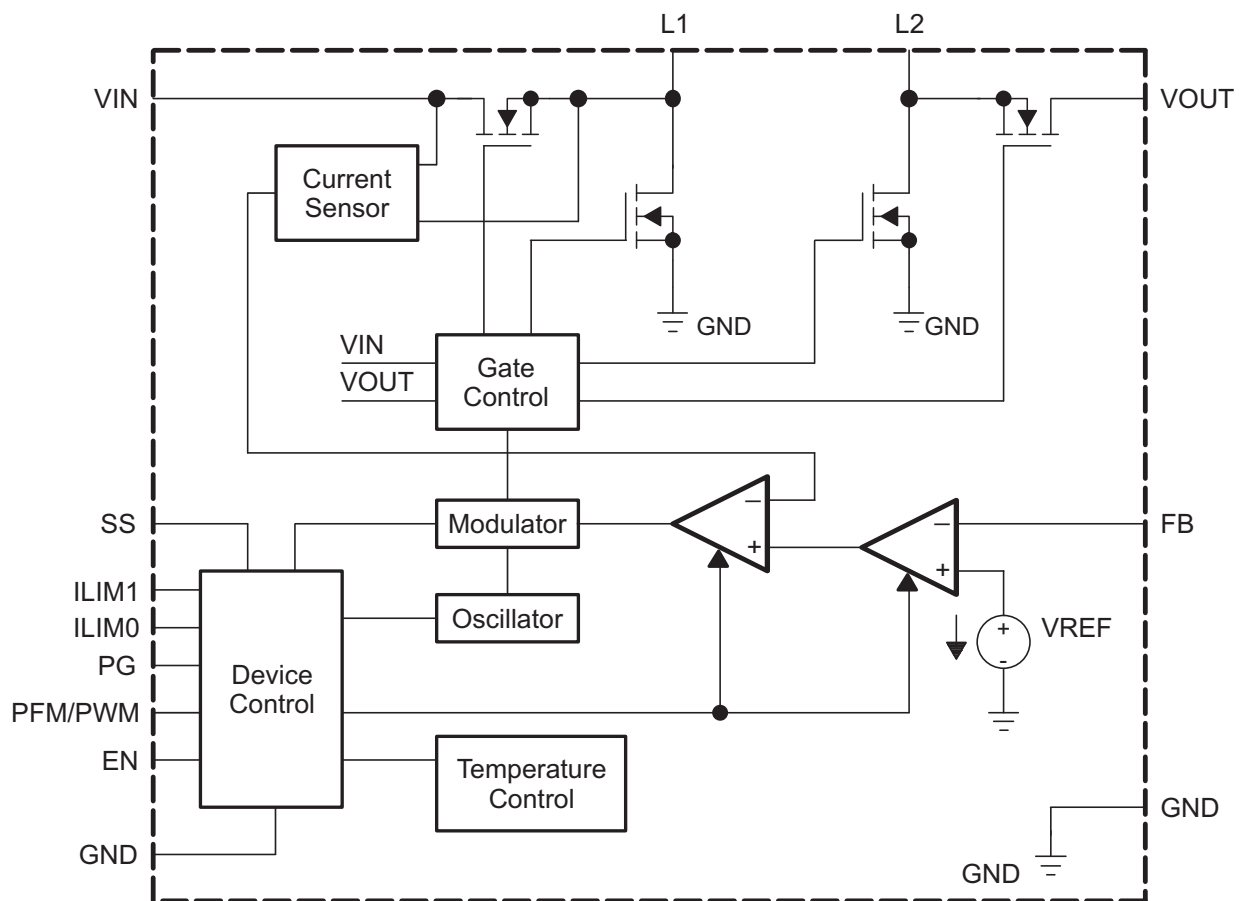

Figure 4. TPS63050 Block Diagram

Functional Block Diagrams (continued)

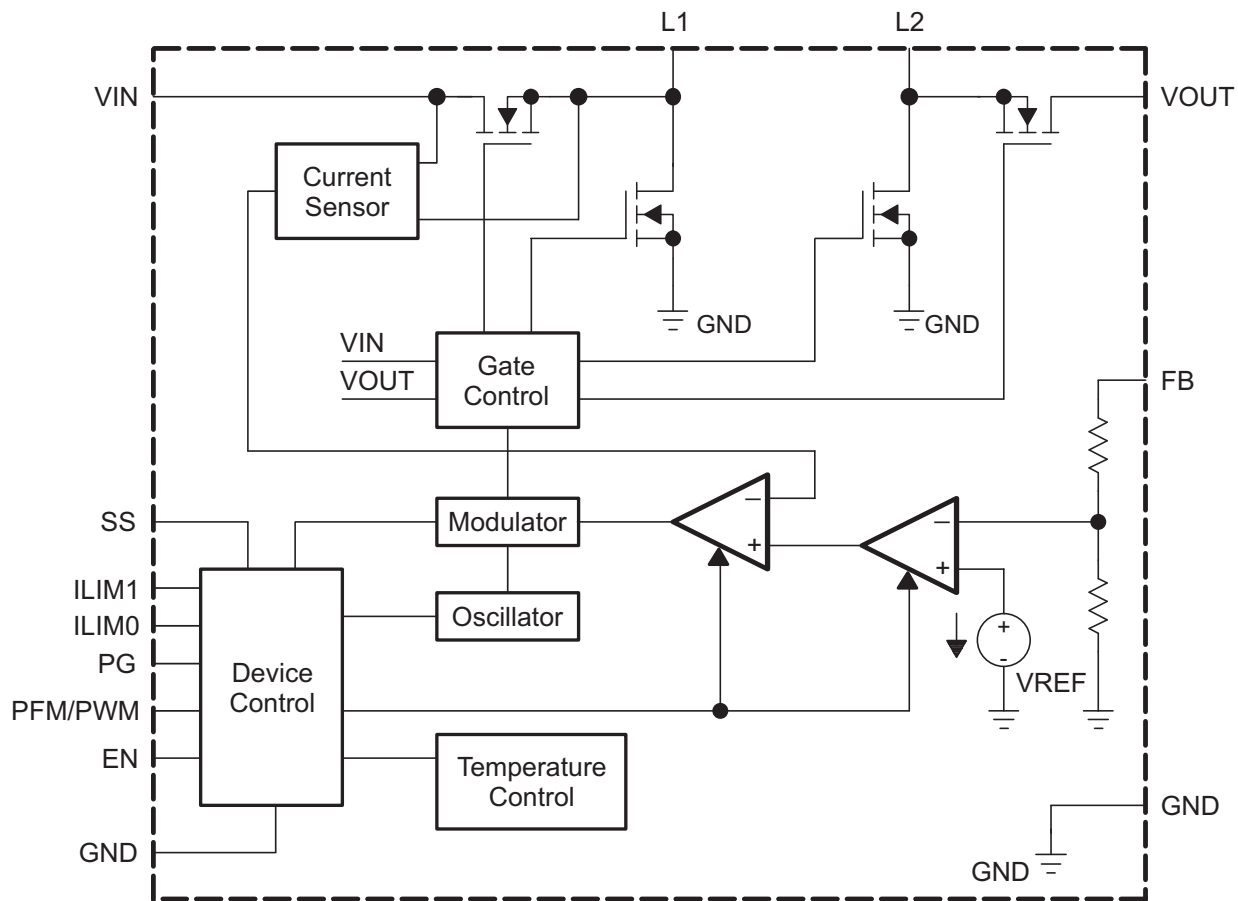

Figure 5. TPS63051 Block Diagram

8.3 Feature Description

8.3.1 Power Good

The TPS6305x devices have a PG output. The power good goes high impedance once the output is above 95% of the nominal voltage, and is driven low once the output voltage falls below typically 90% of the nominal voltage. The PG pin is an open drain output and is specified to sink up to 0.1 mA. The power good output requires a pullup resistor connecting to any voltage rail less than 5.5 V. The power good is valid as long as the converter is enabled and V_{IN} is present. The power good goes low when the device is in undervoltage lockout, in thermal shutdown or in current limit.

If EN is pulled low and one of the pins I_{LIM0} or I_{LIM1} is high, then the PG pin is low. If both pins, I_{LIM0} and I_{LIM1} are low, the PG is open drain. In this case the PG pin, follows its pullup voltage. If this is not desired, one of the two pins I_{LIM0} or I_{LIM1} , must be set high. [Table 1](#) lists the PG pin functionality.

Table 1. Power Good Settings

EN	ILIM1	ILIM0	PG
0	1	1	0
0	1	0	0
0	0	1	0
0	0	0	Open Drain

8.3.2 Overvoltage Protection

Overvoltage protection is implemented to limit the maximum output voltage. In case of overvoltage condition, the voltage amplifier regulates the output voltage to typically 6.7 V.

8.3.3 Undervoltage Lockout (UVLO)

To avoid mis-operation of the device at low input voltages, an undervoltage lockout is included. UVLO shuts down the device at input voltages lower than typically 1.7 V with a 200-mV hysteresis.

8.3.4 Thermal Shutdown

The device goes into thermal shutdown once the junction temperature exceeds typically 140°C with a 20°C hysteresis.

8.3.5 Soft Start

To minimize inrush current and output voltage overshoot during start up, the device has a soft start. At turn on, the input current raises monotonically until the output voltage reaches regulation. The TPS6305x devices charge the soft start capacitor, at the SS pin, with a constant current of typically 1 μ A. The input current follows the current used to charge the capacitor at the SS pin. The soft start operation is completed once the voltage at the SS pin has reached typically 1.3 V. [Figure 3](#) shows the value of the soft start capacitor in respect to the soft-start time.

The soft-start time is the time from when the EN pin is asserted to when the output voltage has reached 90% of its nominal value. There is typically a 100- μ s delay time from EN pin assertion to the start of the switching activity. The soft-start time depends on the load current, the input voltage, and the output capacitor. The soft-start time in boost mode is longer than the time in buck mode and it also depends on the load current, input voltage and output capacitor.

The soft-start time in [Figure 3](#) is referred to typical application with 10- μ F effective output capacitance.

The inductor current is able to increase and always assure a soft start unless a real short circuit is applied at the output.

8.3.6 Short Circuit Protection

The TPS6305x devices provide short circuit protection. When the output voltage does not increase above 1.2 V, a short circuit is detected and the output current is limited to 1.5 A.

8.4 Device Functional Modes

8.4.1 Control Loop Description

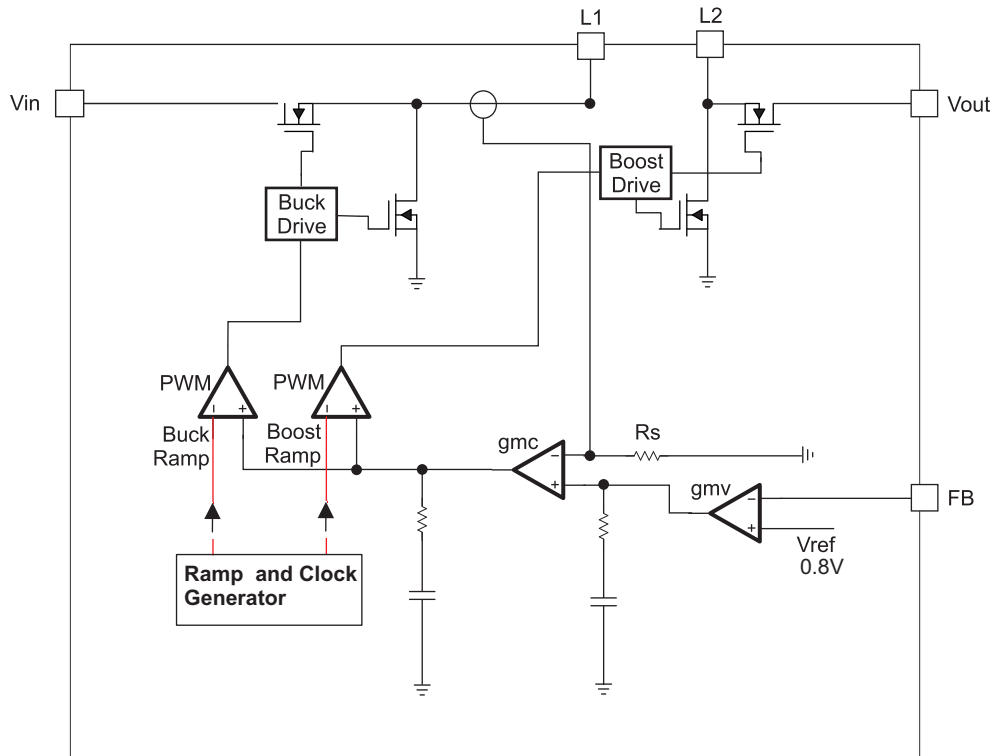

Figure 6. Average Current Mode Control

The controller circuit of the device is based on an average current mode topology. The average inductor current is regulated by a fast current regulator loop which is controlled by a voltage control loop. Figure 6 shows the control loop.

The noninverting input of the transconductance amplifier, gm_v , is assumed to be constant. The output of gm_v defines the average inductor current. The inductor current is reconstructed by measuring the current through the high side buck MOSFET. This current corresponds exactly to the inductor current in boost mode. In buck mode the current is measured during the on time of the same MOSFET. During the off time, the current is reconstructed internally starting from the peak value at the end of the on time cycle. The average current and the feedback from the error amplifier gm_v forms the correction signal gm_c . This correction signal is compared to the buck and the boost sawtooth ramp giving the PWM signal. Depending on which of the two ramps the gm_c output crosses either the Buck or the Boost stage is initiated. When the input voltage is close to the output voltage, one buck cycle is always followed by a boost cycle. In this condition, no more than three cycles in a row of the same mode are allowed. This control method in the buck-boost region ensures a robust control and the highest efficiency.

Device Functional Modes (continued)

8.4.2 Power Save Mode Operation

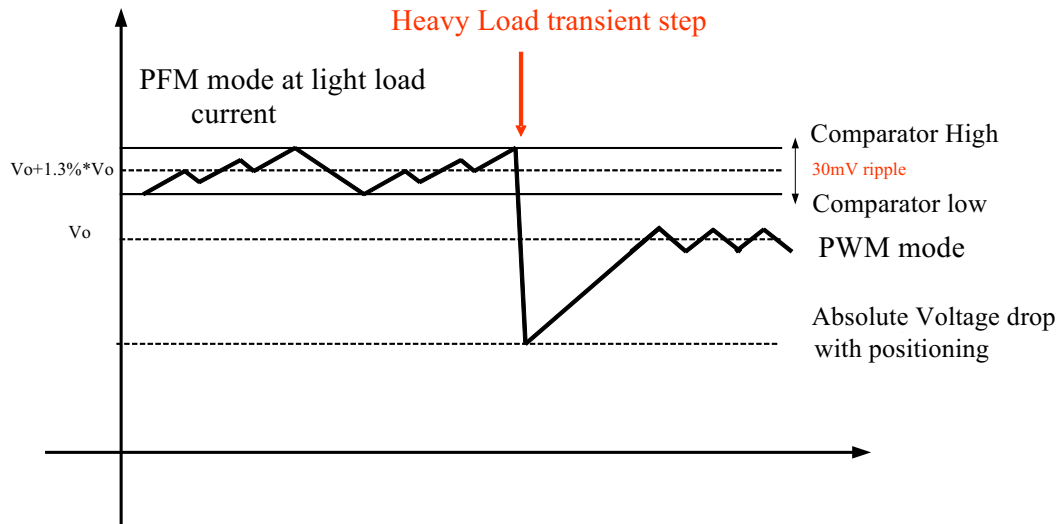

Figure 7. Power Save Mode Operation

Depending on the load current, the device works in PWM mode at load currents of approximately 350 mA or higher to provide the best efficiency over the complete load range. At lighter loads, the device switches automatically into Power Save Mode to reduce power consumption and extend battery life. The PFM/PWM pin is used to select between the two different operation modes. To enable Power Save Mode, the PFM/PWM pin must be set low.

During Power Save Mode, the part operates with a reduced switching frequency and lowest supply current to maintain high efficiency. The output voltage is monitored with a comparator at every clock cycle by the thresholds comp low and comp high. When the device enters Power Save Mode, the converter stops operating and the output voltage drops. The slope of the output voltage depends on the load and the output capacitance. When the output voltage reaches the comp low threshold, at the next clock cycle the device ramps up the output voltage again, by starting operation. Operation can last for one or several pulses until the comp high threshold is reached. At the next clock cycle, if the load is still lower than 150 mA, the device switches off again and the same operation is repeated. If at the next clock cycle the load is above 150 mA, the device automatically switches to PWM mode.

To keep high efficiency in PFM mode, there is only one comparator active to keep the output voltage regulated. The AC ripple in this condition is increased, compared to the PWM mode. The amplitude of this voltage ripple in the worst case scenario is 50 mV peak to peak, (typically 30 mV peak to peak), with 10 μ F of effective output capacitance. To avoid a critical voltage drop when switching from 0 A to full load, the output voltage in PFM mode is typically 1.5% above the nominal value in PWM mode. This is called Dynamic Voltage Positioning and allows the converter to operate with a small output capacitor and still have a low absolute voltage drop during heavy load transients.

Power Save Mode is disabled by setting the PFM/PWM pin high.

8.4.3 Adjustable Current Limit

The TPS6305x devices have an internal user programmable current limit that monitors the input current during start-up. This prevents high inrush current protecting the device and the application. During start-up the input current does not exceed the current limit that is set by I_{LIM0} pin and I_{LIM1} pin. Depending on the logic level applied at these two pins, switching between four different current limit-levels is possible. The variation of those values over input voltage and temperature is shown in [Figure 1](#) through [Figure 2](#). Adjusting the soft-start time further using the soft-start capacitor is possible.

I_{LIM0} and I_{LIM1} set the current limit as listed in [Table 2](#).

Device Functional Modes (continued)

Table 2. Adjustable Current Limit

ILIM1	ILIM0	CURRENT LIMIT SET (WCSP)	CURRENT LIMIT SET (HotRod)
Low	Low	$0.4 \times I_{IN_MAX}$	Not Available
Low	High	$0.5 \times I_{IN_MAX}$	Not Available
High	Low	$0.65 \times I_{IN_MAX}$	$0.65 \times I_{IN_MAX}$
High	High	I_{IN_MAX}	I_{IN_MAX}

The I_{LIM0} , I_{LIM1} pins can be changed during operation.

Given the curves provided in [Figure 1](#) through [Figure 2](#), calculating the output current in the different condition in boost mode is possible using [Equation 1](#) and [Equation 2](#) and in buck mode using [Equation 3](#) and [Equation 4](#).

$$\text{Duty Cycle Boost} \quad D = \frac{V_{OUT} - V_{IN}}{V_{OUT}} \quad (1)$$

$$\text{Output Current Boost} \quad I_{OUT} = \eta \times I_{IN}(1-D)$$

where

- η = Estimated converter efficiency (use the number from the efficiency curves or 0.9 as an assumption)
- I_{IN} = Minimum average input current ([Figure 2](#) to [Figure 2](#))

$$\text{Duty Cycle Buck} \quad D = \frac{V_{OUT}}{V_{IN}} \quad (3)$$

$$\text{Output Current Buck} \quad I_{OUT} = (\eta \times I_{IN}) / D$$

where

- For η , use the number from the efficiency curves or 0.9 as an assumption.

8.4.4 Device Enable

The device starts operation when the EN pin is set high. The device enters shutdown mode when the EN pin is set low. In shutdown mode, the regulator stops switching, all internal control circuitry is switched off, and the load is disconnected from the input.

9 Application and Implementation

NOTE

Information in the following applications sections is not part of the TI component specification, and TI does not warrant its accuracy or completeness. TI's customers are responsible for determining suitability of components for their purposes. Customers must validate and test their design implementation to confirm system functionality.

9.1 Application Information

The TPS6305x is a high efficiency, low quiescent current buck-boost converter suitable for applications where the input voltage is higher or lower than the output voltage. Continuous output current can go as high as 500 mA in boost mode and as high as 1 A in buck mode. The maximum average current in the switches is limited to a typical value of 1 A.

The efficiency measurements

9.2 Typical Application

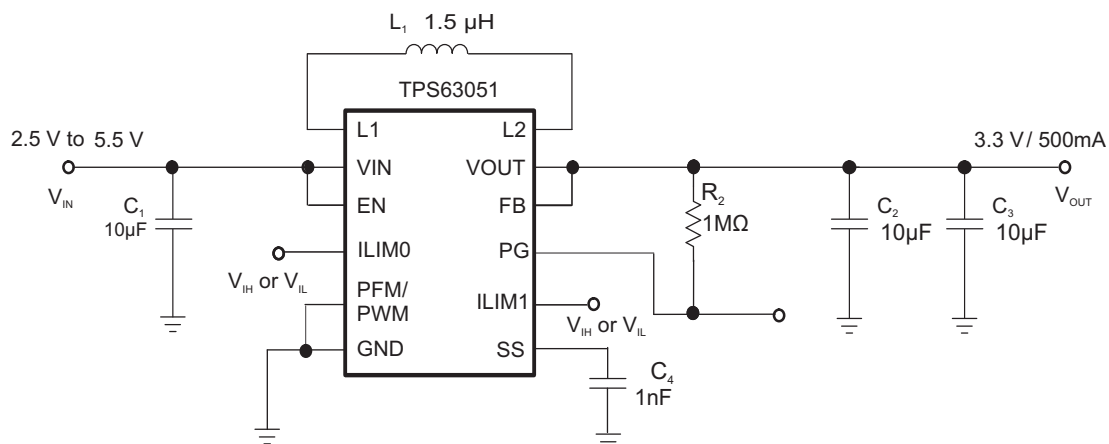

Figure 8. Parameter Measurement Circuit (WCSP)

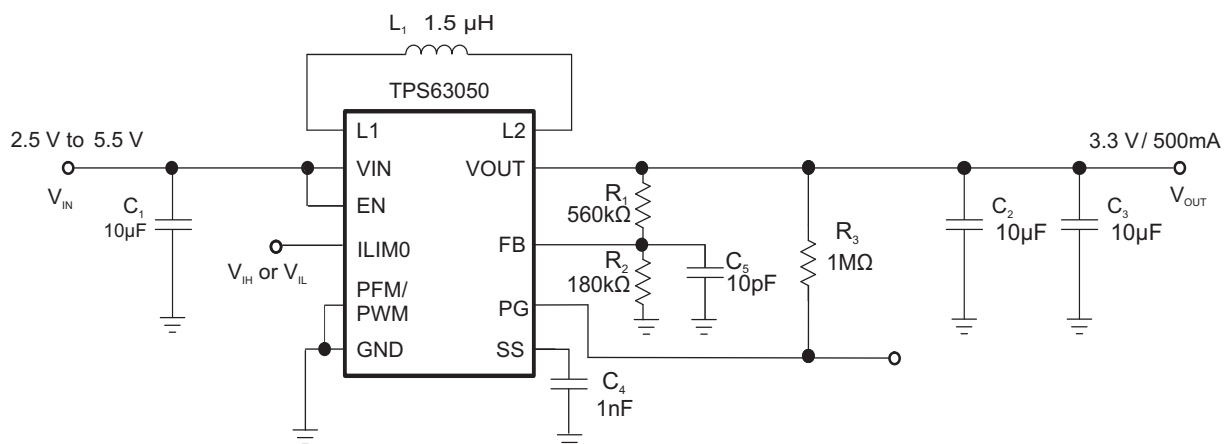

Figure 9. Parameter Measurement Circuit (HotRod)

9.2.1 Design Requirements

The design guidelines provide a component selection to operate the device within the recommended operating conditions.

Typical Application (continued)

9.2.2 Detailed Design Procedure

The first step is the selection of the output filter components, listed in [Table 3](#). To simplify this process, [Table 4](#) outlines possible inductor and capacitor value combinations.

Table 3. Components for Application Characteristic Curves

REFERENCE	DESCRIPTION	MANUFACTURER
	TPS6305x	Texas Instruments
L1	1.5 μ H, 2.1 A, 108 m Ω	1269AS-H-1R5M, TOKO
C1, C2, C3	10 μ F, 6.3 V, 0603, X5R ceramic	GRM188R60J106ME84D, Murata
C4	C _{SS}	
C5	10pF, only needed for the HotRod package version to filter ground noise when using external resistor divider	
R1	Depending on the output voltage of TPS6305x, 0 Ω with TPS63051	
R2	Depending on the output voltage of TPS6305x, not used with TPS63051	
R3	1 M Ω	

9.2.2.1 Output Filter Design

Table 4. Matrix of Output Capacitor and Inductor Combinations

NOMINAL INDUCTOR VALUE [μ H] ⁽¹⁾	NOMINAL OUTPUT CAPACITOR VALUE [μ F] ⁽²⁾				
	10	20	44	66	100
1			+	+	+
1.5	+	+ ⁽³⁾	+	+	+
2.2			+	+	+

(1) Inductor tolerance and current de-rating is anticipated. The effective inductance can vary by 20% and –30%.

(2) Capacitance tolerance and bias voltage de-rating is anticipated. The effective capacitance can vary by 20% and –50%.

(3) Typical application. Other check mark indicates recommended filter combinations

9.2.2.2 Inductor Selection

The inductor selection is affected by several parameter like inductor ripple current, output voltage ripple, transition point into power save mode, and efficiency. See [Table 5](#) for typical inductors.

Table 5. List of Recommended Inductors

INDUCTOR VALUE	COMPONENT SUPPLIER ⁽¹⁾	SIZE (L x W x H mm)	I _{sat} / DCR
1 μ H	TOKO 1286AS-H-1R0M	2 x 1.6 x 1.2	2.1 A / 68 m Ω
1.5 μ H	TOKO, 1286AS-H-1R5M	2 x 1.6 x 1.2	2.5 A / 95 m Ω
1.5 μ H	TOKO, 1269AS-H-1R5M	2.5 x 2 x 1	2.1 A / 90 m Ω
2.2 μ H	TOKO 1286AS-H-2R2M	2 x 1.6 x 1.2	2 A / 160 m Ω

(1) See the [Third-Party Products Disclaimer](#) section.

For high efficiencies, the inductor must have a low dc resistance to minimize conduction losses. Especially at high-switching frequencies, the core material has a high impact on efficiency. When using small chip inductors, the efficiency is reduced mainly due to higher inductor core losses. This needs to be considered when selecting the appropriate inductor. The inductor value determines the inductor ripple current. The larger the inductor value, the smaller the inductor ripple current and the lower the conduction losses of the converter. Conversely, larger inductor values cause a slower load transient response. To avoid saturation of the inductor, the peak current for the inductor in steady state operation is calculated using [Equation 6](#). Only the equation which defines the switch current in boost mode is shown, because this provides the highest value of current and represents the critical current value for selecting inductor.

$$\text{Duty Cycle Boost} \quad D = \frac{V_{\text{OUT}} - V_{\text{IN}}}{V_{\text{OUT}}}$$

where

- D = Duty Cycle in Boost mode (5)

$$I_{\text{PEAK}} = \frac{I_{\text{out}}}{\eta \times (1 - D)} + \frac{V_{\text{in}} \times D}{2 \times f \times L}$$

where

- η = Estimated converter efficiency (use the number from the efficiency curves or 0.80 as an assumption)
- f = Converter switching frequency (typical 2.5MHz)
- L = Inductor value (6)

NOTE

The calculation must be done for the minimum input voltage that is possible to have in boost mode.

Calculating the maximum inductor current using the actual operating conditions gives the minimum saturation current of the inductor needed. It's recommended to choose an inductor with a saturation current 20% higher than the value calculated using [Equation 6](#). Possible inductors are listed in [Table 5](#).

9.2.2.3 Capacitor selection

9.2.2.3.1 Input Capacitor

At least a 10- μF input capacitor is recommended to improve line transient behavior of the regulator and EMI behavior of the total power supply circuit. An X5R or X7R ceramic capacitor placed as close as possible to the VIN and GND pins of the IC is recommended. This capacitance can be increased without limit.

9.2.2.3.2 Output Capacitor

Use of small ceramic capacitors placed as close as possible to the VOUT and PGND pins of the IC, is recommended for the output capacitor. The recommended nominal output capacitance value is 10 μF with a variance as outlined in [Table 4](#).

There is also no upper limit for the output capacitance value. Larger capacitors causes lower output voltage ripple as well as lower output voltage drop during load transients.

9.2.2.4 Setting the Output Voltage

When the adjustable output voltage version TPS63050 is used, the output voltage is set by the external resistor divider. The resistor divider must be connected between VOUT, FB and GND. When the output voltage is regulated properly, the typical value of the voltage at the FB pin is 800 mV. The current through the resistive divider must be 100 times greater than the current into the FB pin. The typical current into the FB pin is 0.1 μA , and the voltage across the resistor between FB and GND, R_2 , is typically 800 mV. Based on these two values, the recommended value for R_2 must be lower than 200 k Ω , in order to set the divider current at 3 μA or higher. It is recommended to keep the value for this resistor in the range of 200 k Ω . The value of the resistor connected between VOUT and FB, R_1 , depending on the needed output voltage (V_{OUT}), can be calculated using [Equation 7](#):

$$R_1 = R_2 \times \left(\frac{V_{\text{OUT}}}{V_{\text{FB}}} - 1 \right) \tag{7}$$

When using the HotRod package version of the TPS63050, it is recommended to add capacitor C_5 , as shown in [Figure 9](#). The capacitor on the feedback node is required to help filtering ground noise and matching the efficiency result shown in the [Application Curves](#) paragraph.

9.2.3 Application Curves

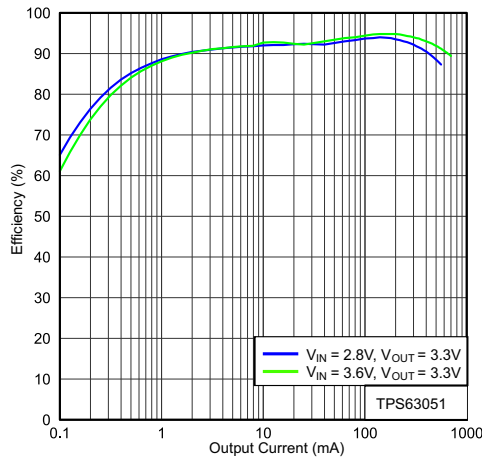

PFM/PWM = Low V_{OUT} = 3.3 V

Figure 10. Efficiency vs Output Current

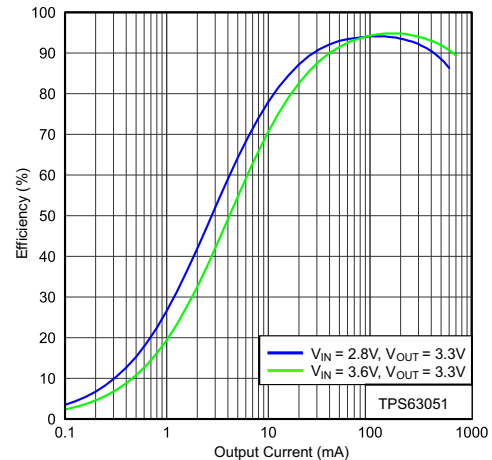

PFM/PWM = High V_{OUT} = 3.3 V

Figure 11. Efficiency vs Output Current

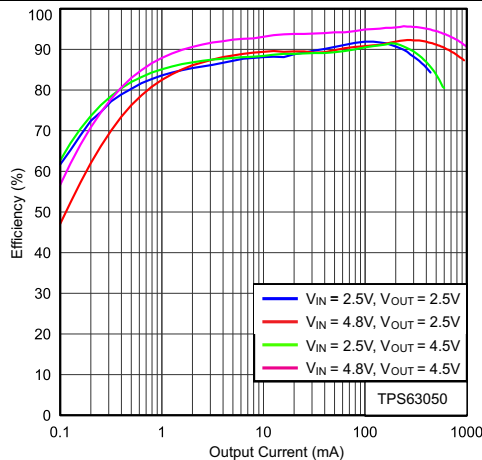

PFM/PWM = Low V_{OUT} = 2.5 V, 4.5 V

Figure 12. Efficiency vs Output Current

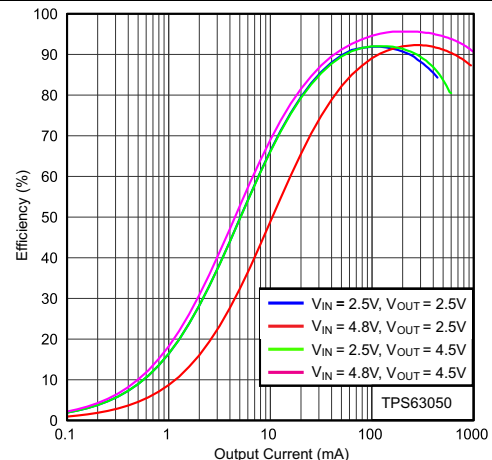

PFM/PWM = High V_{OUT} = 2.5 V, 4.5 V

Figure 13. Efficiency vs Output Current

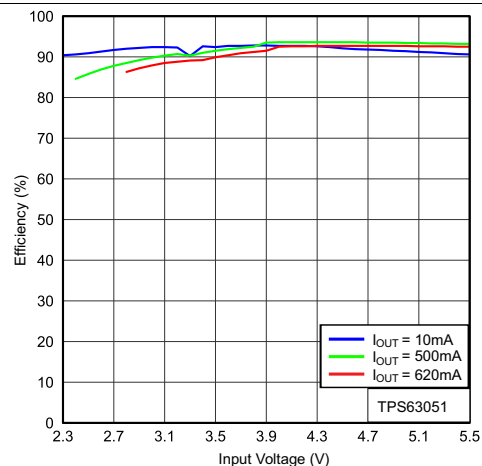

PFM/PWM = Low V_{OUT} = 3.3 V

Figure 14. Efficiency vs Input Voltage

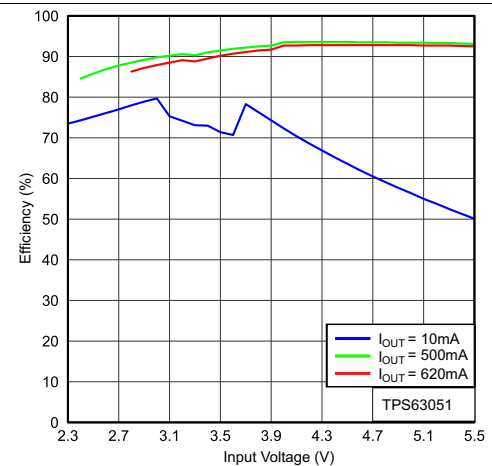

PFM/PWM = High V_{OUT} = 3.3 V

Figure 15. Efficiency vs Input Voltage

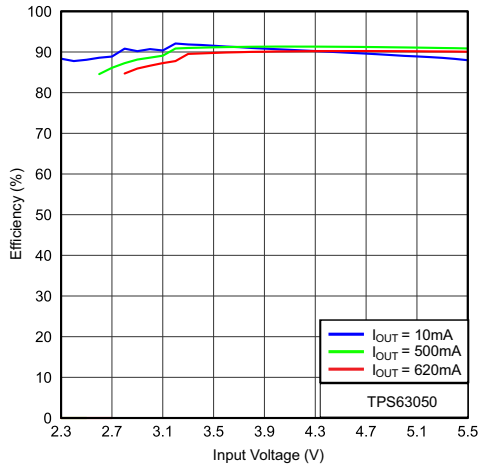

PFM/PWM = Low $V_{OUT} = 2.5\text{ V}$

Figure 16. Efficiency vs Input Voltage

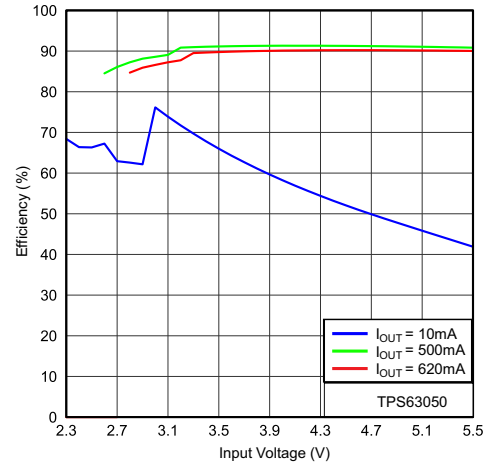

PFM/PWM = High $V_{OUT} = 2.5\text{ V}$

Figure 17. Efficiency vs Input Voltage

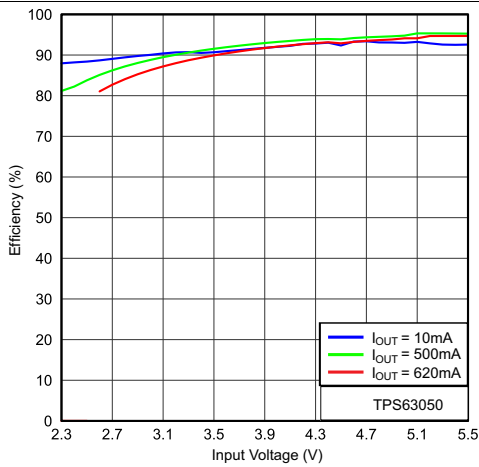

PFM/PWM = Low $V_{OUT} = 4.5\text{ V}$

Figure 18. Efficiency vs Input Voltage

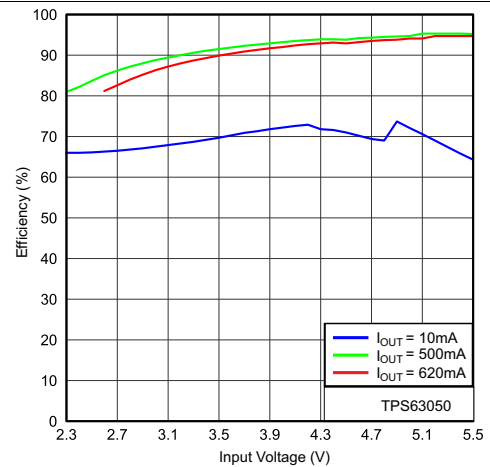

PFM/PWM = High $V_{OUT} = 4.5\text{ V}$

Figure 19. Efficiency vs Input Voltage

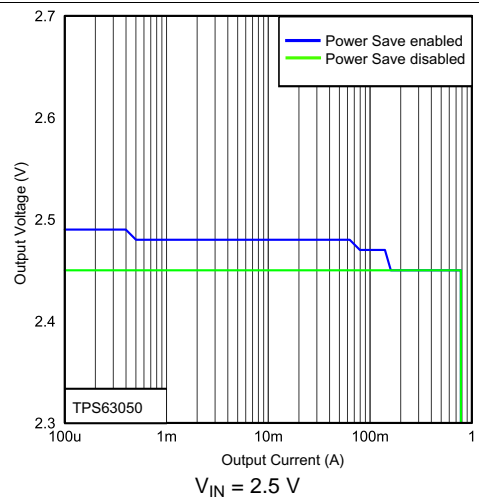

Figure 20. Output Voltage vs Output Current

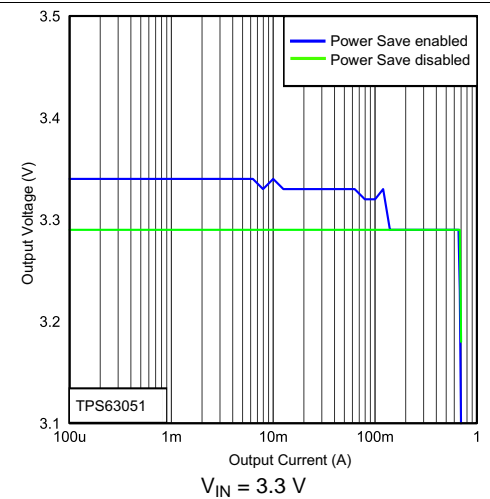

Figure 21. Output Voltage vs Output Current

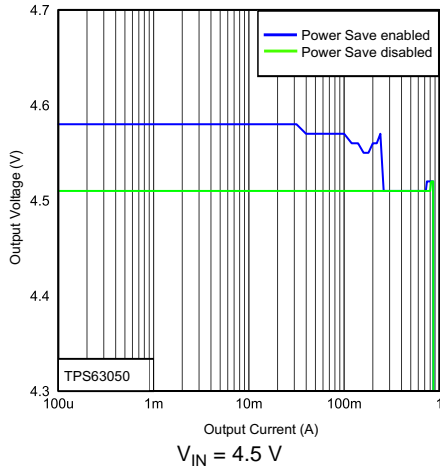

Figure 22. Output Voltage vs Output Current

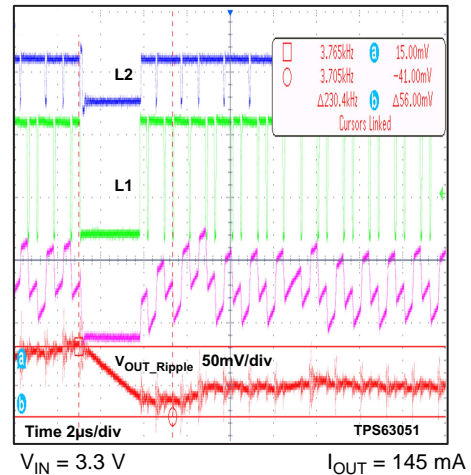

Figure 23. Output Voltage ripple in Buck-Boost mode and PFM to PWM transition

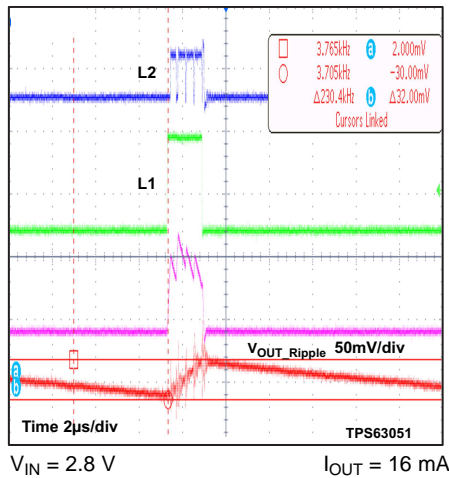

Figure 24. Output Voltage Ripple in Boost Mode and PFM to PWM Transition

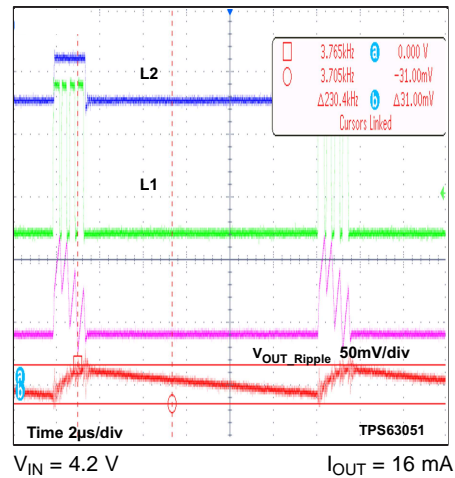

Figure 25. Output Voltage Ripple in Buck Mode and PFM to PWM Transition

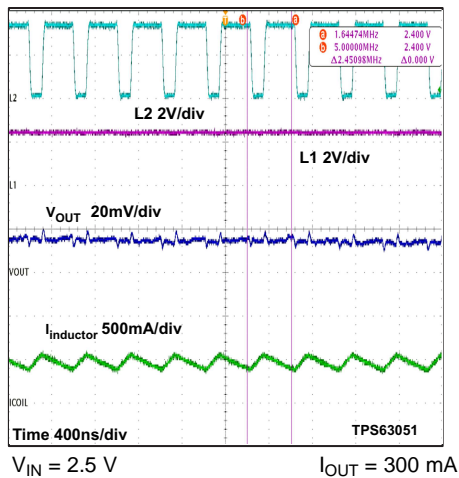

Figure 26. Switching Waveform in Boost Mode and PWM

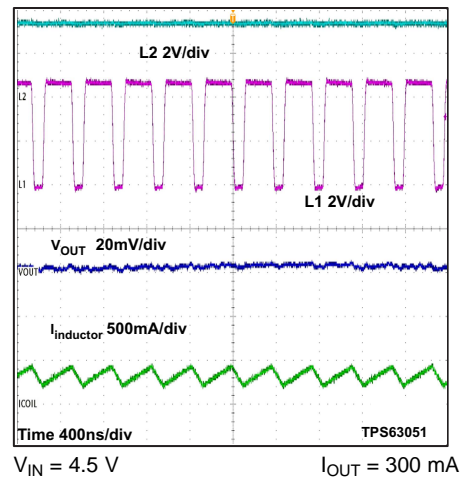

Figure 27. Switching Waveform in Buck Mode and PWM

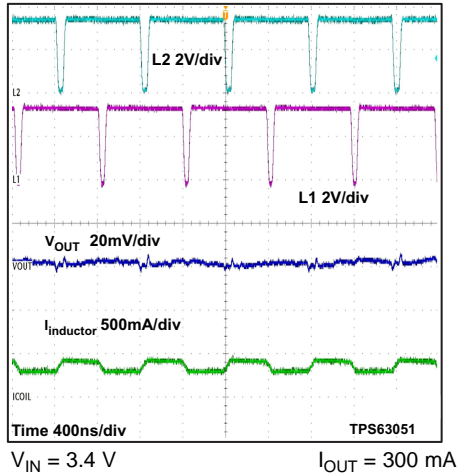

Figure 28. Switching Waveform in Buck-Boost Mode and PWM

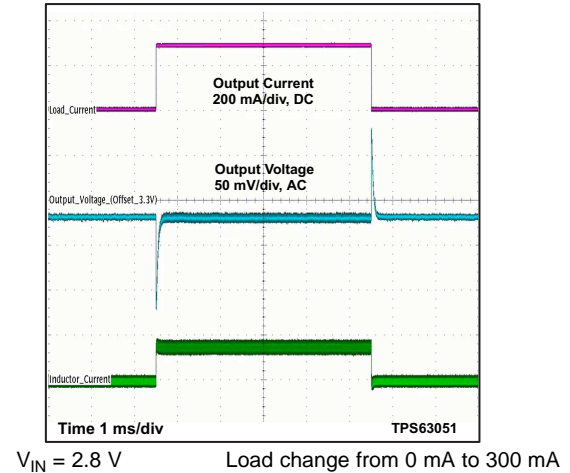

Figure 29. Load Transient Response

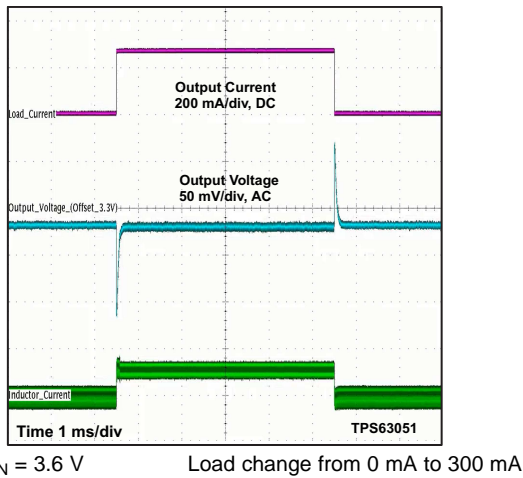

Figure 30. Load Transient Response

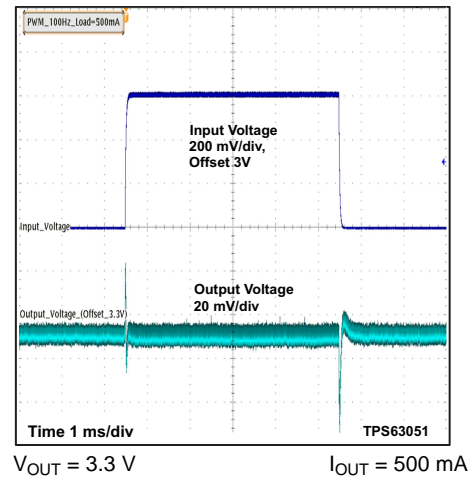

Figure 31. Line Transient Response

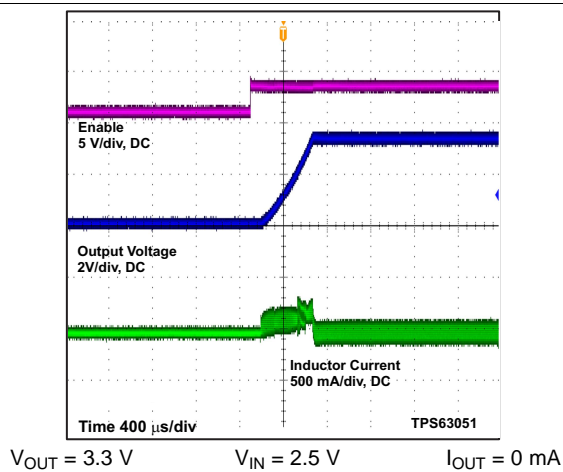

Figure 32. Start Up After Enable

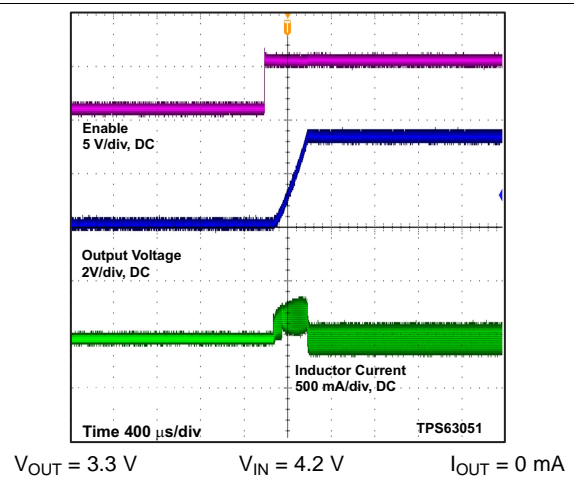

Figure 33. Start Up After Enable

10 Power Supply Recommendations

The TPS6305x device family has no special requirements for its input power supply. The input power supply's output current needs to be rated according to the supply voltage, output voltage and output current of the TPS6305x devices.

11 Layout

11.1 Layout Guidelines

The PCB layout is an important step to maintain the high performance of the TPS6305x devices.

- Place input and output capacitors as close as possible to the IC. Traces need to be kept short. Routing wide and direct traces to the input and output capacitor results in low-trace resistance and low parasitic inductance.
- Use a common-power GND.
- The sense trace connected to FB is signal trace. Keep these traces away from L1 and L2 nodes.
- For the HotRod package option it is important to add a capacitor between FB node and ground to filter ground noise and to match efficiency results documented in these datasheet.

11.2 Layout Example (WCSP)

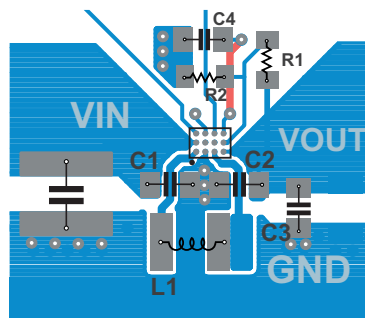

Figure 34. TPS6305x Layout (WCSP)

11.3 Layout Example (HotRod)

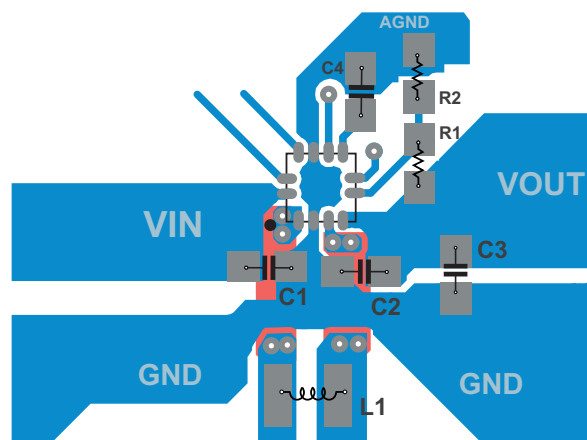

Figure 35. TPS6305x Layout (HotRod)

11.4 Thermal Considerations

Implementation of integrated circuits in low-profile and fine-pitch surface-mount packages typically requires special attention to power dissipation. Many system-dependent issues such as thermal coupling, airflow, added heat sinks and convection surfaces, and the presence of other heat-generating components affect the powerdissipation limits of a given component.

Two basic approaches for enhancing thermal performance are listed below:

- Improving the power dissipation capability of the PCB design
- Introducing airflow in the system

For more details on how to use the thermal parameters, see the application notes: *Thermal Characteristics (SZZA017)*, and *Semiconductor and IC Package Thermal Metrics (SPRA953)*

12 器件和文档支持

12.1 器件支持

12.1.1 Third-Party Products Disclaimer

TI'S PUBLICATION OF INFORMATION REGARDING THIRD-PARTY PRODUCTS OR SERVICES DOES NOT CONSTITUTE AN ENDORSEMENT REGARDING THE SUITABILITY OF SUCH PRODUCTS OR SERVICES OR A WARRANTY, REPRESENTATION OR ENDORSEMENT OF SUCH PRODUCTS OR SERVICES, EITHER ALONE OR IN COMBINATION WITH ANY TI PRODUCT OR SERVICE.

12.2 相关链接

下面的表格列出了快速访问链接。范围包括技术文档、支持与社区资源、工具和软件，以及样片或购买的快速访问。

表 6. 相关链接

部件	产品文件夹	样片与购买	技术文档	工具与软件	支持与社区
TPS63050	请单击此处	请单击此处	请单击此处	请单击此处	请单击此处
TPS63051	请单击此处	请单击此处	请单击此处	请单击此处	请单击此处

12.3 商标

All trademarks are the property of their respective owners.

12.4 静电放电警告



这些装置包含有限的内置 ESD 保护。存储或装卸时，应将导线一起截短或将装置放置于导电泡棉中，以防止 MOS 门极遭受静电损伤。

12.5 Glossary

[SLYZ022](#) — *TI Glossary*.

This glossary lists and explains terms, acronyms, and definitions.

13 机械、封装和可订购信息

以下页中包括机械、封装和可订购信息。这些信息是针对指定器件可提供的最新数据。这些数据会在无通知且不对本文档进行修订的情况下发生改变。欲获得该数据表的浏览器版本，请查阅左侧的导航栏。

重要声明

德州仪器(TI)及其下属子公司有权根据 JESD46 最新标准,对所提供的产品和服务进行更正、修改、增强、改进或其它更改,并有权根据 JESD48 最新标准中止提供任何产品和服务。客户在下订单前应获取最新的相关信息,并验证这些信息是否完整且是最新的。所有产品的销售都遵循在订单确认时所提供的TI 销售条款与条件。

TI 保证其所销售的组件的性能符合产品销售时 TI 半导体产品销售条件与条款的适用规范。仅在 TI 保证的范围内,且 TI 认为有必要时才会使用测试或其它质量控制技术。除非适用法律做出了硬性规定,否则没有必要对每种组件的所有参数进行测试。

TI 对应用帮助或客户产品设计不承担任何义务。客户应对其使用 TI 组件的产品和应用自行负责。为尽量减小与客户产品和应用相关的风险,客户应提供充分的设计与操作安全措施。

TI 不对任何 TI 专利权、版权、屏蔽作品权或其它与使用了 TI 组件或服务的组合设备、机器或流程相关的 TI 知识产权中授予的直接或隐含权限作出任何保证或解释。TI 所发布的与第三方产品或服务有关的信息,不能构成从 TI 获得使用这些产品或服务的许可、授权、或认可。使用此类信息可能需要获得第三方的专利权或其它知识产权方面的许可,或是 TI 的专利权或其它知识产权方面的许可。

对于 TI 的产品手册或数据表中 TI 信息的重要部分,仅在没有对内容进行任何篡改且带有相关授权、条件、限制和声明的情况下才允许进行复制。TI 对此类篡改过的文件不承担任何责任或义务。复制第三方的信息可能需要服从额外的限制条件。

在转售 TI 组件或服务时,如果对该组件或服务参数的陈述与 TI 标明的参数相比存在差异或虚假成分,则会失去相关 TI 组件或服务的所有明示或暗示授权,且这是不正当的、欺诈性商业行为。TI 对任何此类虚假陈述均不承担任何责任或义务。

客户认可并同意,尽管任何应用相关信息或支持仍可能由 TI 提供,但他们将独立负责满足与其产品及其在应用中使用的 TI 产品相关的所有法律、法规和安全相关要求。客户声明并同意,他们具备制定与实施安全措施所需的全部专业技术和知识,可预见故障的危险后果、监测故障及其后果、降低有可能造成人身伤害的故障的发生机率并采取适当的补救措施。客户将全额赔偿因在此类安全关键应用中使用任何 TI 组件而对 TI 及其代理造成的任何损失。

在某些场合中,为了推进安全相关应用有可能对 TI 组件进行特别的促销。TI 的目标是利用此类组件帮助客户设计和创立其特有的可满足适用的功能安全性标准和要求的终端产品解决方案。尽管如此,此类组件仍然服从这些条款。

TI 组件未获得用于 FDA Class III (或类似的生命攸关医疗设备)的授权许可,除非各方授权官员已经达成了专门管控此类使用的特别协议。

只有那些 TI 特别注明属于军用等级或“增强型塑料”的 TI 组件才是设计或专门用于军事/航空应用或环境的。购买者认可并同意,对并非指定面向军事或航空航天用途的 TI 组件进行军事或航空航天方面的应用,其风险由客户单独承担,并且由客户独立负责满足与此类使用相关的所有法律和法规要求。

TI 已明确指定符合 ISO/TS16949 要求的产品,这些产品主要用于汽车。在任何情况下,因使用非指定产品而无法达到 ISO/TS16949 要求, TI 不承担任何责任。

	产品		应用
数字音频	www.ti.com.cn/audio	通信与电信	www.ti.com.cn/telecom
放大器和线性器件	www.ti.com.cn/amplifiers	计算机及周边	www.ti.com.cn/computer
数据转换器	www.ti.com.cn/dataconverters	消费电子	www.ti.com.cn/consumer-apps
DLP® 产品	www.dlp.com	能源	www.ti.com.cn/energy
DSP - 数字信号处理器	www.ti.com.cn/dsp	工业应用	www.ti.com.cn/industrial
时钟和计时器	www.ti.com.cn/clockandtimers	医疗电子	www.ti.com.cn/medical
接口	www.ti.com.cn/interface	安防应用	www.ti.com.cn/security
逻辑	www.ti.com.cn/logic	汽车电子	www.ti.com.cn/automotive
电源管理	www.ti.com.cn/power	视频和影像	www.ti.com.cn/video
微控制器 (MCU)	www.ti.com.cn/microcontrollers		
RFID 系统	www.ti.com.cn/rfidsys		
OMAP应用处理器	www.ti.com/omap		
无线连通性	www.ti.com.cn/wirelessconnectivity	德州仪器在线技术支持社区	www.deyisupport.com

邮寄地址: 上海市浦东新区世纪大道1568号, 中建大厦32楼邮政编码: 200122
Copyright © 2016, 德州仪器半导体技术(上海)有限公司

PACKAGING INFORMATION

Orderable Device	Status (1)	Package Type	Package Drawing	Pins	Package Qty	Eco Plan (2)	Lead/Ball Finish (6)	MSL Peak Temp (3)	Op Temp (°C)	Device Marking (4/5)	Samples
TPS63050RMWR	ACTIVE	VQFN-HR	RMW	12	3000	Green (RoHS & no Sb/Br)	CU NIPDAU	Level-1-260C-UNLIM	-40 to 85	F630	Samples
TPS63050RMWT	ACTIVE	VQFN-HR	RMW	12	250	Green (RoHS & no Sb/Br)	CU NIPDAU	Level-1-260C-UNLIM	-40 to 85	F630	Samples
TPS63050YFFR	ACTIVE	DSBGA	YFF	12	3000	Green (RoHS & no Sb/Br)	SNAGCU	Level-1-260C-UNLIM	-40 to 85	63050	Samples
TPS63050YFFT	ACTIVE	DSBGA	YFF	12	250	Green (RoHS & no Sb/Br)	SNAGCU	Level-1-260C-UNLIM	-40 to 85	63050	Samples
TPS63051RMWR	ACTIVE	VQFN-HR	RMW	12	3000	Green (RoHS & no Sb/Br)	CU NIPDAU	Level-1-260C-UNLIM	-40 to 85	F631	Samples
TPS63051RMWT	ACTIVE	VQFN-HR	RMW	12	250	Green (RoHS & no Sb/Br)	CU NIPDAU	Level-1-260C-UNLIM	-40 to 85	F631	Samples
TPS63051YFFR	ACTIVE	DSBGA	YFF	12	3000	Green (RoHS & no Sb/Br)	SNAGCU	Level-1-260C-UNLIM	-40 to 85	63051	Samples
TPS63051YFFT	ACTIVE	DSBGA	YFF	12	250	Green (RoHS & no Sb/Br)	SNAGCU	Level-1-260C-UNLIM	-40 to 85	63051	Samples

(1) The marketing status values are defined as follows:

ACTIVE: Product device recommended for new designs.

LIFEBUY: TI has announced that the device will be discontinued, and a lifetime-buy period is in effect.

NRND: Not recommended for new designs. Device is in production to support existing customers, but TI does not recommend using this part in a new design.

PREVIEW: Device has been announced but is not in production. Samples may or may not be available.

OBSOLETE: TI has discontinued the production of the device.

(2) Eco Plan - The planned eco-friendly classification: Pb-Free (RoHS), Pb-Free (RoHS Exempt), or Green (RoHS & no Sb/Br) - please check <http://www.ti.com/productcontent> for the latest availability information and additional product content details.

TBD: The Pb-Free/Green conversion plan has not been defined.

Pb-Free (RoHS): TI's terms "Lead-Free" or "Pb-Free" mean semiconductor products that are compatible with the current RoHS requirements for all 6 substances, including the requirement that lead not exceed 0.1% by weight in homogeneous materials. Where designed to be soldered at high temperatures, TI Pb-Free products are suitable for use in specified lead-free processes.

Pb-Free (RoHS Exempt): This component has a RoHS exemption for either 1) lead-based flip-chip solder bumps used between the die and package, or 2) lead-based die adhesive used between the die and leadframe. The component is otherwise considered Pb-Free (RoHS compatible) as defined above.

Green (RoHS & no Sb/Br): TI defines "Green" to mean Pb-Free (RoHS compatible), and free of Bromine (Br) and Antimony (Sb) based flame retardants (Br or Sb do not exceed 0.1% by weight in homogeneous material)

(3) MSL, Peak Temp. - The Moisture Sensitivity Level rating according to the JEDEC industry standard classifications, and peak solder temperature.

(4) There may be additional marking, which relates to the logo, the lot trace code information, or the environmental category on the device.

(5) Multiple Device Markings will be inside parentheses. Only one Device Marking contained in parentheses and separated by a "~" will appear on a device. If a line is indented then it is a continuation of the previous line and the two combined represent the entire Device Marking for that device.

(6) Lead/Ball Finish - Orderable Devices may have multiple material finish options. Finish options are separated by a vertical ruled line. Lead/Ball Finish values may wrap to two lines if the finish value exceeds the maximum column width.

Important Information and Disclaimer:The information provided on this page represents TI's knowledge and belief as of the date that it is provided. TI bases its knowledge and belief on information provided by third parties, and makes no representation or warranty as to the accuracy of such information. Efforts are underway to better integrate information from third parties. TI has taken and continues to take reasonable steps to provide representative and accurate information but may not have conducted destructive testing or chemical analysis on incoming materials and chemicals. TI and TI suppliers consider certain information to be proprietary, and thus CAS numbers and other limited information may not be available for release.

In no event shall TI's liability arising out of such information exceed the total purchase price of the TI part(s) at issue in this document sold by TI to Customer on an annual basis.

TAPE AND REEL INFORMATION

QUADRANT ASSIGNMENTS FOR PIN 1 ORIENTATION IN TAPE

*All dimensions are nominal

Device	Package Type	Package Drawing	Pins	SPQ	Reel Diameter (mm)	Reel Width W1 (mm)	A0 (mm)	B0 (mm)	K0 (mm)	P1 (mm)	W (mm)	Pin1 Quadrant
TPS63050RMWR	VQFN-HR	RMW	12	3000	180.0	8.4	2.8	2.8	1.0	4.0	8.0	Q2
TPS63050RMWT	VQFN-HR	RMW	12	250	180.0	8.4	2.8	2.8	1.0	4.0	8.0	Q2
TPS63050YFFR	DSBGA	YFF	12	3000	180.0	8.4	1.39	1.79	0.7	4.0	8.0	Q1
TPS63050YFFT	DSBGA	YFF	12	250	180.0	8.4	1.39	1.79	0.7	4.0	8.0	Q1
TPS63051RMWR	VQFN-HR	RMW	12	3000	180.0	8.4	2.8	2.8	1.0	4.0	8.0	Q2
TPS63051RMWT	VQFN-HR	RMW	12	250	180.0	8.4	2.8	2.8	1.0	4.0	8.0	Q2
TPS63051YFFR	DSBGA	YFF	12	3000	180.0	8.4	1.39	1.79	0.7	4.0	8.0	Q1
TPS63051YFFT	DSBGA	YFF	12	250	180.0	8.4	1.39	1.79	0.7	4.0	8.0	Q1

TAPE AND REEL BOX DIMENSIONS

*All dimensions are nominal

Device	Package Type	Package Drawing	Pins	SPQ	Length (mm)	Width (mm)	Height (mm)
TPS63050RMWR	VQFN-HR	RMW	12	3000	210.0	185.0	35.0
TPS63050RMWT	VQFN-HR	RMW	12	250	210.0	185.0	35.0
TPS63050YFFR	DSBGA	YFF	12	3000	182.0	182.0	20.0
TPS63050YFFT	DSBGA	YFF	12	250	182.0	182.0	20.0
TPS63051RMWR	VQFN-HR	RMW	12	3000	210.0	185.0	35.0
TPS63051RMWT	VQFN-HR	RMW	12	250	210.0	185.0	35.0
TPS63051YFFR	DSBGA	YFF	12	3000	182.0	182.0	20.0
TPS63051YFFT	DSBGA	YFF	12	250	182.0	182.0	20.0

YFF0012

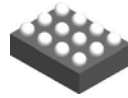

PACKAGE OUTLINE

DSBGA - 0.625 mm max height

DIE SIZE BALL GRID ARRAY

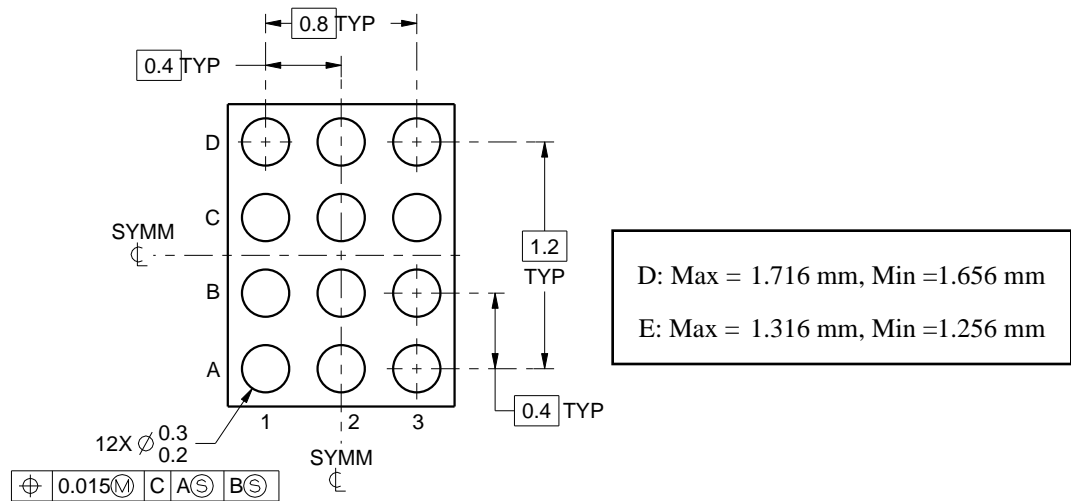
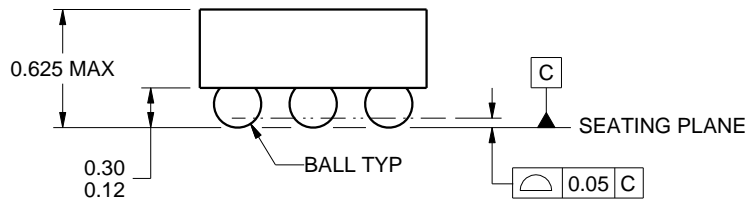
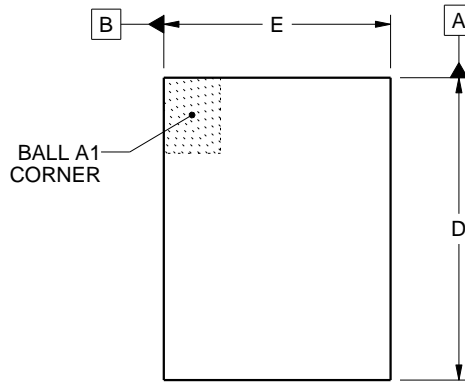

4222191/A 07/2015

NOTES:

1. All linear dimensions are in millimeters. Any dimensions in parenthesis are for reference only. Dimensioning and tolerancing per ASME Y14.5M.
2. This drawing is subject to change without notice.

EXAMPLE BOARD LAYOUT

YFF0012

DSBGA - 0.625 mm max height

DIE SIZE BALL GRID ARRAY

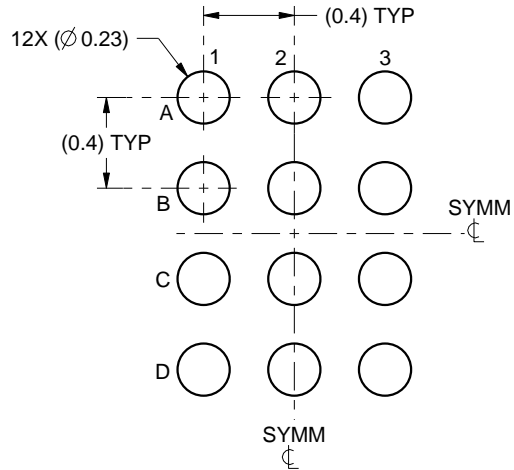

LAND PATTERN EXAMPLE
SCALE:30X

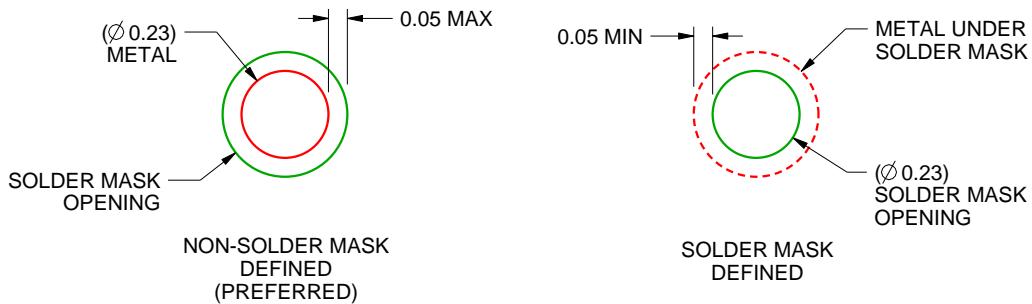

SOLDER MASK DETAILS
NOT TO SCALE

4222191/A 07/2015

NOTES: (continued)

3. Final dimensions may vary due to manufacturing tolerance considerations and also routing constraints. For more information, see Texas Instruments literature number SNVA009 (www.ti.com/lit/snva009).

EXAMPLE STENCIL DESIGN

YFF0012

DSBGA - 0.625 mm max height

DIE SIZE BALL GRID ARRAY

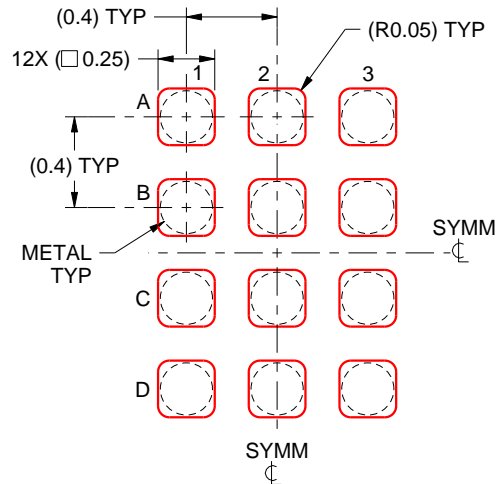

SOLDER PASTE EXAMPLE
BASED ON 0.1 mm THICK STENCIL
SCALE:30X

4222191/A 07/2015

NOTES: (continued)

4. Laser cutting apertures with trapezoidal walls and rounded corners may offer better paste release.

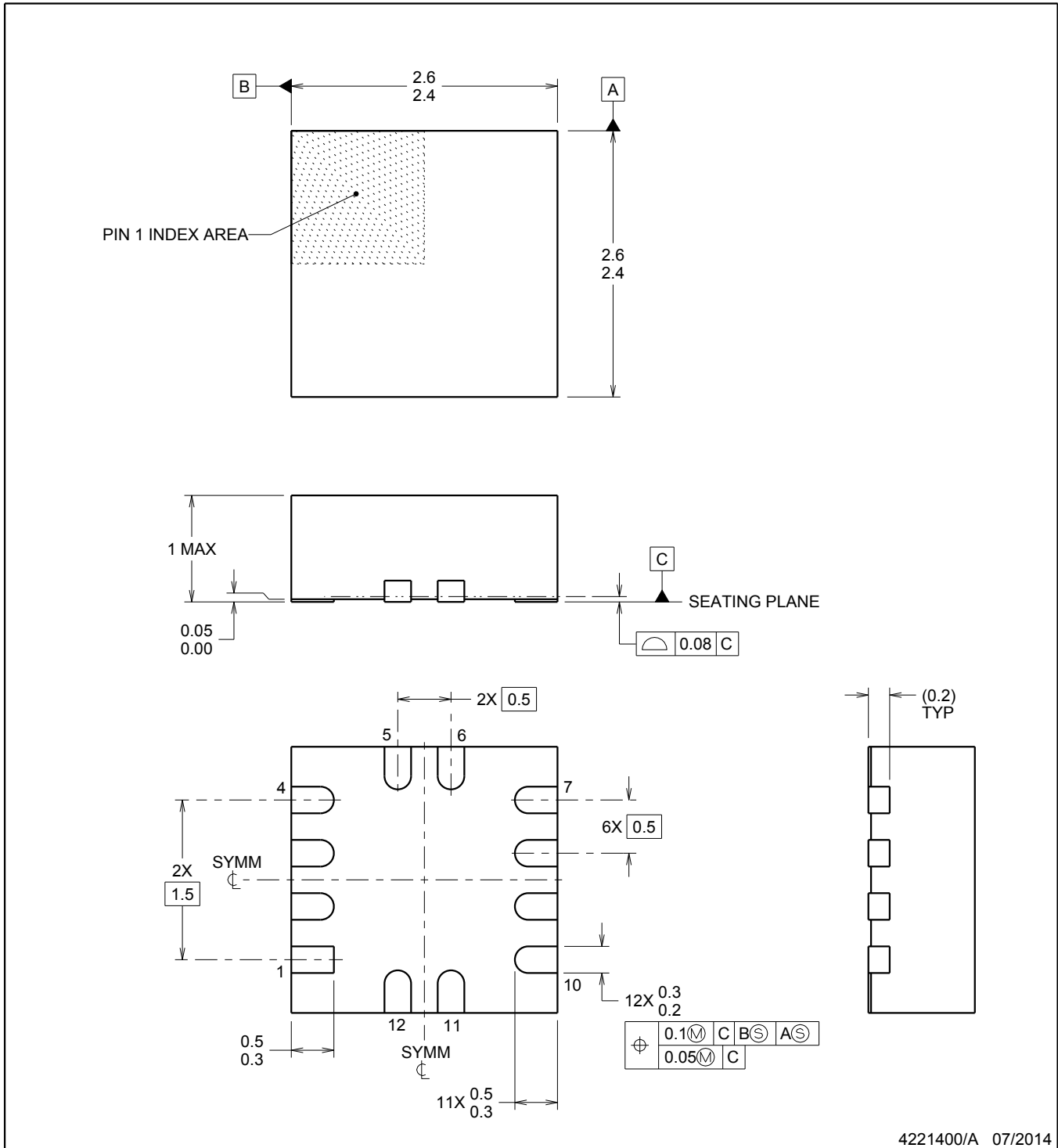
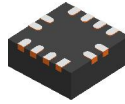

4221400/A 07/2014

NOTES:

1. All linear dimensions are in millimeters. Any dimensions in parenthesis are for reference only. Dimensioning and tolerancing per ASME Y14.5M.
2. This drawing is subject to change without notice.

EXAMPLE BOARD LAYOUT

RMW0012A

VQFN - 1 mm max height

PLASTIC QUAD FLAT PACK - NO LEAD

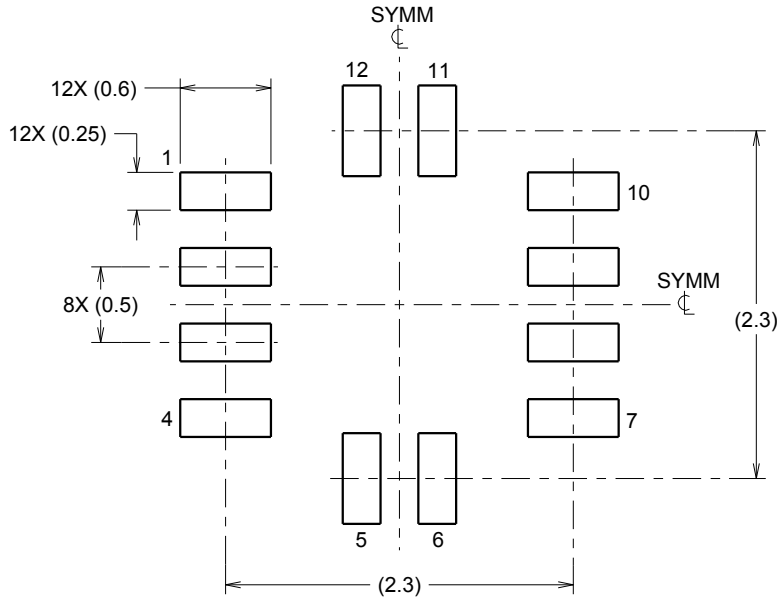

LAND PATTERN EXAMPLE
SCALE:20X

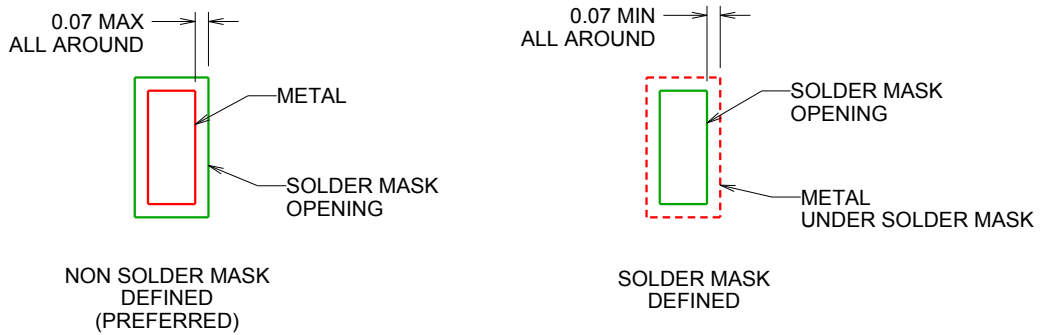

SOLDER MASK DETAILS

4221400/A 07/2014

NOTES: (continued)

3. For more information, see Texas Instruments literature number SLUA271 (www.ti.com/lit/slua271).

EXAMPLE STENCIL DESIGN

RMW0012A

VQFN - 1 mm max height

PLASTIC QUAD FLAT PACK - NO LEAD

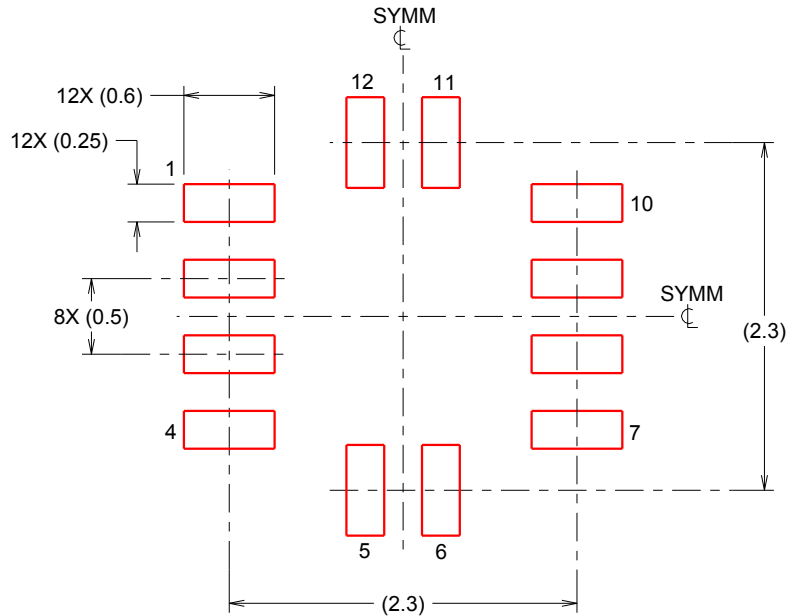

SOLDER PASTE EXAMPLE
BASED ON 0.125 mm THICK STENCIL
SCALE:20X

4221400/A 07/2014

NOTES: (continued)

4. Laser cutting apertures with trapezoidal walls and rounded corners may offer better paste release. IPC-7525 may have alternate design recommendations.

重要声明

德州仪器(TI) 及其下属子公司有权根据 JESD46 最新标准, 对所提供的产品和服务进行更正、修改、增强、改进或其它更改, 并有权根据 JESD48 最新标准中止提供任何产品和服务。客户在下订单前应获取最新的相关信息, 并验证这些信息是否完整且是最新的。所有产品的销售都遵循在订单确认时所提供的TI 销售条款与条件。

TI 保证其所销售的组件的性能符合产品销售时 TI 半导体产品销售条件与条款的适用规范。仅在 TI 保证的范围内, 且 TI 认为有必要时才会使用测试或其它质量控制技术。除非适用法律做出了硬性规定, 否则没有必要对每种组件的所有参数进行测试。

TI 对应用帮助或客户产品设计不承担任何义务。客户应对其使用 TI 组件的产品和应用自行负责。为尽量减小与客户产品和应用相关的风险, 客户应提供充分的设计与操作安全措施。

TI 不对任何 TI 专利权、版权、屏蔽作品权或其它与使用了 TI 组件或服务的组合设备、机器或流程相关的 TI 知识产权中授予的直接或间接权限制作出任何保证或解释。TI 所发布的与第三方产品或服务有关的信息, 不能构成从 TI 获得使用这些产品或服务的许可、授权、或认可。使用此类信息可能需要获得第三方的专利权或其它知识产权方面的许可, 或是 TI 的专利权或其它知识产权方面的许可。

对于 TI 的产品手册或数据表中 TI 信息的重要部分, 仅在没有对内容进行任何篡改且带有相关授权、条件、限制和声明的情况下才允许进行复制。TI 对此类篡改过的文件不承担任何责任或义务。复制第三方的信息可能需要服从额外的限制条件。

在转售 TI 组件或服务时, 如果对该组件或服务参数的陈述与 TI 标明的参数相比存在差异或虚假成分, 则会失去相关 TI 组件或服务的所有明示或暗示授权, 且这是不正当的、欺诈性商业行为。TI 对任何此类虚假陈述均不承担任何责任或义务。

客户认可并同意, 尽管任何应用相关信息或支持仍可能由 TI 提供, 但他们将独自负责满足与其产品及其应用中使用 TI 产品相关的所有法律、法规和安全相关要求。客户声明并同意, 他们具备制定与实施安全措施所需的全部专业技术和知识, 可预见故障的危险后果、监测故障及其后果、降低有可能造成人身伤害的故障的发生机率并采取适当的补救措施。客户将全额赔偿因在此类安全关键应用中使用任何 TI 组件而对 TI 及其代理造成的任何损失。

在某些场合中, 为了推进安全相关应用有可能对 TI 组件进行特别的促销。TI 的目标是利用此类组件帮助客户设计和创立其特有的可满足适用的功能安全性标准和要求的终端产品解决方案。尽管如此, 此类组件仍然服从这些条款。

TI 组件未获得用于 FDA Class III (或类似的生命攸关医疗设备) 的授权许可, 除非各方授权官员已经达成了专门管控此类使用的特别协议。

只有那些 TI 特别注明属于军用等级或“增强型塑料”的 TI 组件才是设计或专门用于军事/航空应用或环境的。购买者认可并同意, 对并非指定面向军事或航空航天用途的 TI 组件进行军事或航空航天方面的应用, 其风险由客户单独承担, 并且由客户独自负责满足与此类使用相关的所有法律和法规要求。

TI 已明确指定符合 ISO/TS16949 要求的产品, 这些产品主要用于汽车。在任何情况下, 因使用非指定产品而无法达到 ISO/TS16949 要求, TI 不承担任何责任。

	产品		应用
数字音频	www.ti.com.cn/audio	通信与电信	www.ti.com.cn/telecom
放大器和线性器件	www.ti.com.cn/amplifiers	计算机及周边	www.ti.com.cn/computer
数据转换器	www.ti.com.cn/dataconverters	消费电子	www.ti.com.cn/consumer-apps
DLP® 产品	www.dlp.com	能源	www.ti.com.cn/energy
DSP - 数字信号处理器	www.ti.com.cn/dsp	工业应用	www.ti.com.cn/industrial
时钟和计时器	www.ti.com.cn/clockandtimers	医疗电子	www.ti.com.cn/medical
接口	www.ti.com.cn/interface	安防应用	www.ti.com.cn/security
逻辑	www.ti.com.cn/logic	汽车电子	www.ti.com.cn/automotive
电源管理	www.ti.com.cn/power	视频和影像	www.ti.com.cn/video
微控制器 (MCU)	www.ti.com.cn/microcontrollers		
RFID 系统	www.ti.com.cn/rfidsys		
OMAP应用处理器	www.ti.com.cn/omap		
无线连通性	www.ti.com.cn/wirelessconnectivity	德州仪器在线技术支持社区	www.deyisupport.com

Mailing Address: Texas Instruments, Post Office Box 655303, Dallas, Texas 75265
Copyright © 2016, Texas Instruments Incorporated