



ISO14001



ISO/TS16949



244546



245468



REG.-Nr.A759



CQC04001010050

## Specification for Approval

Customer : 深圳市立創電子商務有限公司

Product Name: LEAD-FREE HIGH POWER LOW THICK FILM CHIP RESISTORS

Part Name : HP SERIES

Part No. : HP\*\*\*\*\*T\*E

Building 8, Jiuwei Industrial Zone, Xixiang Town, Bao'An District ,Shenzhen, Guangdong, China  
Guangdong Province, China

TEL: 0755-27484508

FAX: 0755-27484308

Approved	Checked	Prepared	File NO.	Edition	Date	Page
William Zhao	Ted Hsu	Chengxia Tang	JLC-01-013	1	2017/05/09	1 / 12



## Content

1.0 Scope .....	4
2.0 Ratings &Dimension.....	4
3.0 Power Rating.....	5
4.0 Voltage Rating.....	5
5.0 Structure.....	5
6.0 Marking.....	6
7.0 Performance Specification .....	8
8.0 Explanation of Part No. System.....	9
9.0 Ordering Procedure .....	10
10.0 Packing.....	10
11.0 Note.....	12

Approved	Checked	Prepared	File NO.	Edition	Date	Page
William Zhao	Ted Hsu	Chengxia Tang	JLC-01-013	1	2017/05/09	2 / 12

厚聲國際貿易（昆山）有限公司深圳分公司

Uniroyal Electronics Global Co.,Ltd Shenzhen Branch



File Name: <b>HP SERIES</b>		Date	<b>2017/05/09</b>	Edition No.	<b>1</b>
Amendment Record				Signature	
Edition	Description	Page	Date	Amended by	Checked by

Approved	Checked	Prepared	File NO.	Edition	Date	Page
<b>William Zhao</b>	<b>Ted Hsu</b>	<b>Chengxia Tang</b>	<b>JLC-01-013</b>	<b>1</b>	<b>2017/05/09</b>	<b>3 / 12</b>



## 1.0 Scope:

This file is specification of **Lead-Free High Power Thick Film Chip Resistors** made by UNIOHM.

## 2.0 Ratings & dimension:

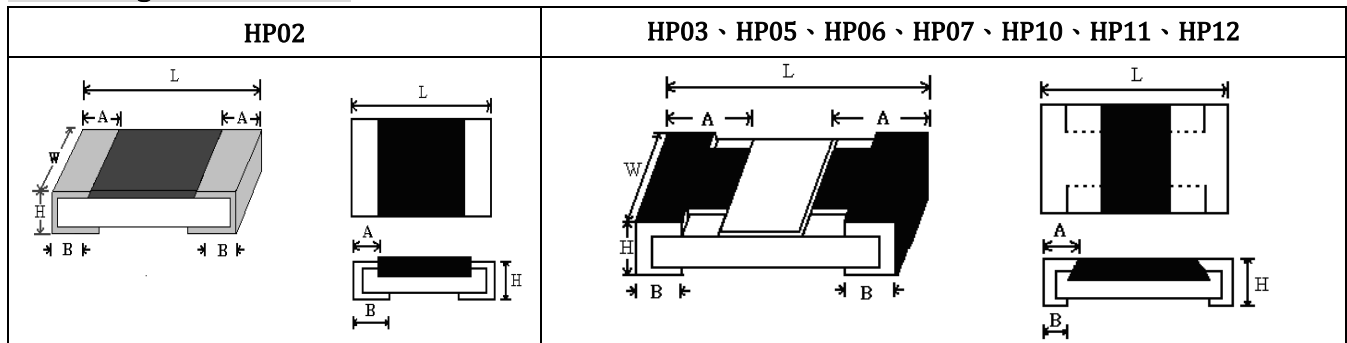

Dimension (mm)

Type	HP02	HP03	HP05	HP06	HP07	HP10	HP11	HP12	SP12	
Power Rating at 70°C	1/10W	1/5W	1/3W	1/2W	3/4W	1W	1.25W	2W	3W	
Dimension (mm)	L	1.00±0.10	1.60±0.10	2.00±0.15	3.10±0.15	3.10±0.10	5.00±0.10	4.50±0.20	6.35±0.10	6.35±0.10
	W	0.50±0.05	0.80±0.10	1.25 <sup>+0.15</sup> <sub>-0.10</sub>	1.55 <sup>+0.15</sup> <sub>-0.10</sub>	2.60±0.20	2.50±0.20	3.20±0.20	3.20±0.20	3.20±0.20
	H	0.35±0.05	0.45±0.10	0.55±0.10	0.55±0.10	0.55±0.10	0.55±0.10	0.55±0.20	0.55±0.10	1.10±0.10
	A	0.20±0.10	0.30±0.20	0.40±0.20	0.45±0.20	0.50±0.25	0.60±0.25	0.50±0.20	0.60±0.25	0.60±0.25
	B	0.25±0.10	0.30±0.20	0.40±0.20	0.45±0.20	0.50±0.20	0.50±0.20	0.50±0.20	0.50±0.20	1.80±0.20
Resistance range	±1%	0Ω 1Ω-10MΩ	0Ω 0.1Ω-10MΩ	0Ω 10mΩ-10MΩ	0Ω 10mΩ-10MΩ	0Ω 0.1Ω-10MΩ	0Ω 10mΩ~10MΩ	0Ω 0.1Ω~10MΩ	0Ω 10mΩ~10MΩ	0Ω 1Ω~10MΩ
	±5%	0Ω 1Ω-10MΩ	0Ω 0.1Ω-10MΩ	0Ω 10mΩ-10MΩ	0Ω 10mΩ-10MΩ	0Ω 0.1Ω-10MΩ	0Ω 10mΩ-10MΩ	0Ω 0.1Ω~10MΩ	0Ω 10mΩ~10MΩ	0Ω 1Ω~10MΩ
Max Working Voltage	50V	50V	150V	200V	200V	200V	200V	250V	250V	
Max Overload Voltage	100V	100V	300V	400V	500V	500V	500V	500V	500V	
Dielectric Withstanding Voltage	100V	300V	500V	500V	500V	500V	500V	500V	500V	
Operating Temperature	-55 ~ +155°C									

Approved	Checked	Prepared	File NO.	Edition	Date	Page
William Zhao	Ted Hsu	Chengxia Tang	JLC-01-013	1	2017/05/09	4 / 12



### 3.0 Power rating:

Resistors shall have a power rating based on continuous load operation at an ambient temperature from -55°C to 70°C. For temperature in excess of 70°C, the load shall be derate as shown in figure 1.

Figure 1

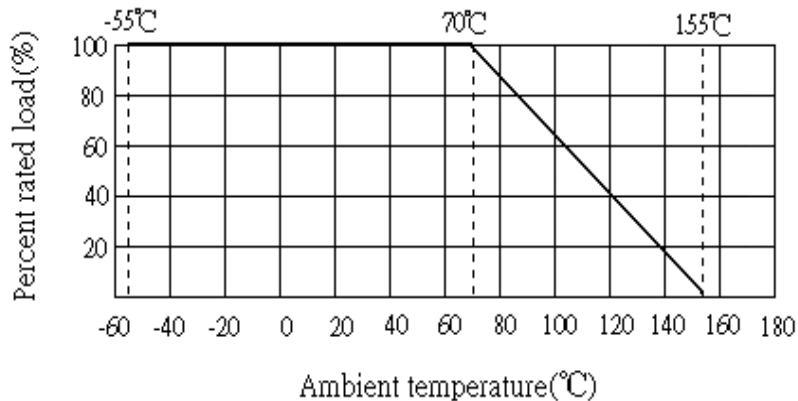

### 4.0 Voltage rating:

Resistors should have a direct-current (DC) continuous voltage rating and an alternating-current (AC) continuous voltage rating relates to Power Rating, formula shown as below:

$$RCWV = \sqrt{P * R}$$

RCWV: Rated dc or RMS ac continuous working voltage(Volt.)

P: Power Rating (Watt.)

R: Nominal Resistance (Ohm)

Resistors will be burned out if it overload, such as higher than the maximum value of series' RCWV. And we named 2.5 times RCWV is OVERLOAD Voltage.

### 5.0 Structure:

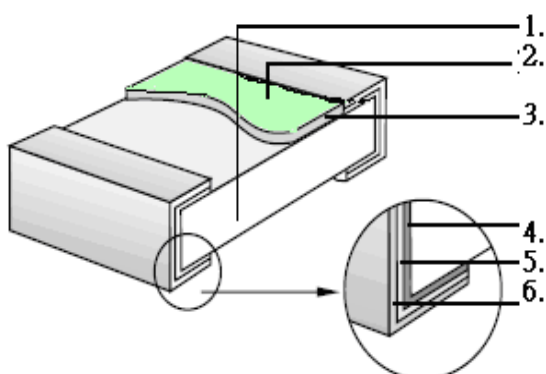

- 1) High purity alumina substrate
- 2) Protective covering
- 3) Resistive element
- 4) Termination inner (Ni/Cr)
- 5) Termination (between) Ni Barrier
- 6) Termination (outer) Sn

Approved	Checked	Prepared	File NO.	Edition	Date	Page
William Zhao	Ted Hsu	Chengxia Tang	JLC-01-013	1	2017/05/09	5 / 12



## 6.0 Marking

- 6.1  $\pm 5\%$  tolerance: Two codes ahead of mark are significant figures of resistance and the third code is power of ten.

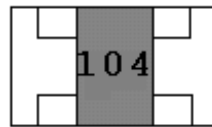

$$104 = 10 \times 10^4 \rightarrow 100\text{K}\Omega$$

- 6.2  $\pm 5\%$  tolerance: If resistance value is below  $10\Omega$ , mark show as following: "R" means decimal point.

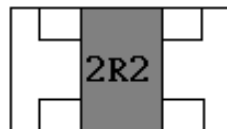

$$2R2 \rightarrow 2.2\Omega$$

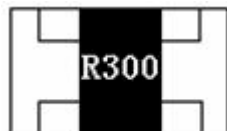

$$R300 \rightarrow 0.3\Omega$$

- 6.3  $\pm 1\%$  Tolerance: Three codes ahead are significant; Forth code is power. R means decimal point.

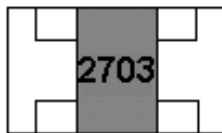

$$2703 = 270 \times 10^3 \rightarrow 270\text{K}\Omega$$

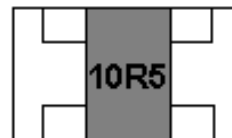

$$10R5 \rightarrow 10.5\Omega$$

- 6.4 E-96 series standard values ( $\pm 1\%$  tolerance) of HP03. Due to tiny size, there are 3 codes on body only, which means resistance value shown as following:

Code	A	B	C	D	E	F	G	H	X	Y	Z
Power	$10^0$	$10^1$	$10^2$	$10^3$	$10^4$	$10^5$	$10^6$	$10^7$	$10^{-1}$	$10^{-2}$	$10^{-3}$

Two digits ahead: Resistance code; Third code: power code

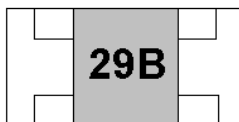

$$1.96\text{K}\Omega = 196 \times 10^1 \Omega \rightarrow 29B$$

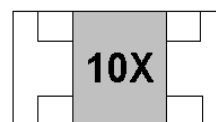

$$12.4\Omega = 124 \times 10^{-1} \Omega \rightarrow 10X$$

### E-96 SERIES STANDARD VALUES AND HP03 RESISTANCE CODE

Approved	Checked	Prepared	File NO.	Edition	Date	Page
William Zhao	Ted Hsu	Chengxia Tang	JLC-01-013	1	2017/05/09	6 / 12

# 厚聲國際貿易（昆山）有限公司深圳分公司

Uniroyal Electronics Global Co.,Ltd Shenzhen Branch



VALUE	CODE	VALUE	CODE	VALUE	CODE	VALUE	CODE
100	01	178	25	316	49	562	73
102	02	182	26	324	50	576	74
105	03	187	27	332	51	590	75
107	04	191	28	340	52	604	76
110	05	196	29	348	53	619	77
113	06	200	30	357	54	634	78
115	07	205	31	365	55	649	79
118	08	210	32	374	56	665	80
121	09	215	33	383	57	681	81
124	10	221	34	392	58	698	82
127	11	226	35	402	59	715	83
130	12	232	36	412	60	732	84
133	13	237	37	422	61	750	85
137	14	243	38	432	62	768	86
140	15	249	39	442	63	787	87
143	16	255	40	453	64	806	88
147	17	261	41	464	65	825	89
150	18	267	42	475	66	845	90
154	19	274	43	487	67	866	91
158	20	280	44	499	68	887	92
162	21	287	45	511	69	909	93
165	22	294	46	523	70	931	94
169	23	301	47	536	71	953	95
174	24	309	48	549	72	976	96

6.5 E-24 series standard value but not belongs to E-96 series standard values (in  $\pm 1\%$  tolerance):

The marking is the same to 5% tolerance but with UNDERLINE signed

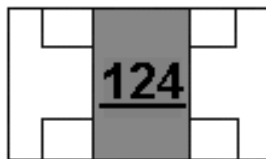

124→12\*10<sup>4</sup>=120KΩ

Approved	Checked	Prepared	File NO.	Edition	Date	Page
William Zhao	Ted Hsu	Chengxia Tang	JLC-01-013	1	2017/05/09	7 / 12

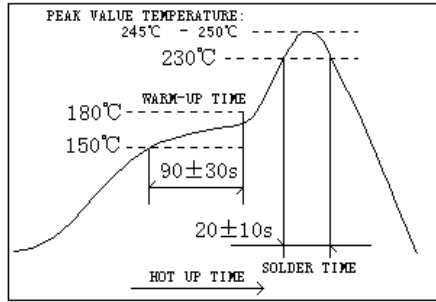

7.0 Performance specification:

Item	Limits	Test Method (JIS-C-5201&JIS-C-5202)
Temperature Coefficient	HP02: 1Ω≤R ≤ 10Ω: ±400 ppm/°C 10Ω<R ≤100Ω: ±200 ppm/°C 100Ω<R ≤10M : ±100 ppm/°C	4.8 Natural resistance changes per temp. Degree centigrade $\frac{R_2 - R_1}{R_1(T_2 - T_1)} * 10^6 (PPM/°C)$ R1: resistance value at room temp. (T1) R2: resistance value at room temp. +100°C (Tt2) Test pattern: room temp. (T1), room temp. +100°C(T2)
	HP03: 0.1Ω~0.2Ω: ±200PPM/°C >0.2Ω: ±100PPM/°C	
	HP05: ±100PPM/°C	
	HP06 : 50mΩ~0.1Ω:±150PPM/°C >0.1Ω: ±100PPM/°C	
	HP07、HP10、HP11:±100PPM/°C	
	HP12: 50mΩ~0.1Ω:±75PPM/°C >0.1Ω: ±100PPM/°C	
Short-time overload	±5%     ±(2.0%+0.1Ω) Max	4.13 Permanent resistance change after the application of 2.5 times RCWV for 5 seconds.
	±1%     ±(1.0%+0.1Ω) Max	
Dielectric withstanding voltage	No evidence of flashover mechanical damage, arcing or insulation breaks done.	4.7 Clamped in the trough of a 90°C metallic v-block and shall be tested at ac potential respectively specified in the type for 60-70 seconds
Terminal bending	±(1.0%+0.05Ω) Max	4.33 Twist of test board: Y/x = 3/90 mm for 60seconds
Soldering heat	Resistance change rate is ±(1.0%+0.05Ω) Max	4.18 Dipping the resistor into a solder bath having a temperature of 260°C±5°C and hold it for 10±1 seconds
Solderability	95% coverage Min.	Wave solder: Test temperature of solder: 245°C±3°C dipping time in solder: 2-3 seconds.
		Reflow: 

Approved	Checked	Prepared	File NO.	Edition	Date	Page
William Zhao	Ted Hsu	Chengxia Tang	JLC-01-013	1	2017/05/09	8 / 12





Temperature cycling	±5%	±(1.0%+0.05 Ω)Max	4.19Resistance change after continuous five cycles for duty cycle specified below: <table border="1"> <thead> <tr> <th>STEP</th> <th>TEMPERATURE</th> <th>TIME</th> </tr> </thead> <tbody> <tr> <td>1</td> <td>-55°C±3°C</td> <td>30 MIN</td> </tr> <tr> <td>2</td> <td>ROOM TEMP.</td> <td>10 -- 15 MIN</td> </tr> <tr> <td>3</td> <td>+155°C±2°C</td> <td>30 MIN</td> </tr> <tr> <td>4</td> <td>ROOM TEMP.</td> <td>10 --- 15 MIN</td> </tr> </tbody> </table>	STEP	TEMPERATURE	TIME	1	-55°C±3°C	30 MIN	2	ROOM TEMP.	10 -- 15 MIN	3	+155°C±2°C	30 MIN	4	ROOM TEMP.	10 --- 15 MIN
	STEP	TEMPERATURE		TIME														
1	-55°C±3°C	30 MIN																
2	ROOM TEMP.	10 -- 15 MIN																
3	+155°C±2°C	30 MIN																
4	ROOM TEMP.	10 --- 15 MIN																
±1%	±(0.5%+0.05 Ω)Max																	
Item	Limits		Test Method (JIS-C-5201&JIS-C-5202)															
Humidity steady state	±5%	±(3.0%+0.1Ω) Max.	4.24Temporary resistance change after 240 hours exposure in a humidity test chamber controlled at 40±2°C and 90-95% relative humidity,															
	±1%	±(0.5%+0.1Ω) Max.																
Load life in humidity	±5%	±(3.0%+0.1Ω) Max.	7.9 Resistance change after 1,000 hours (1.5 hours "ON",0.5 hour "OFF") at RCWV in a humidity chamber controlled at 40°C±2°C and 90 to 95% relative humidity.															
	±1%	±(1.0%+0.1Ω) Max.																
Load life	±5%	±(3.0%+0.1Ω) Max.	4.25.1 Permanent resistance change after 1,000 hours operating at RCWV with duty cycle 1.5 hours "ON", 0.5 hour "OFF" at 70°C±2°C ambient.															
	±1%	±(1.0%+0.1Ω) Max.																

### 8.0 Part No. System:

Part No. System has 14 codes:

8.1 1<sup>st</sup> ~4<sup>th</sup> : Product series name

Example: HP03、HP05、HP06、HP07、HP10、HP11、HP12

8.2 5<sup>th</sup>~6<sup>th</sup> codes: Power rating.

8.2.1 For those power rating higher than 1W: the 6<sup>th</sup> code will be "W".

8.2.2 For those power rating lower than 1W: the 5<sup>th</sup> code will be "W".

8.2.3 Code rules shown as below:

Wattage	1/2	1/3	1/4	1/5	1/6	3/4	1/8	1/10	1/16	1	1.25	2	3
Normal Size	W2	W3	W4	W5	W6	/	W8	WA	WG	1W	1Q	2W	3W

8.3 7<sup>th</sup> digit: Resistance Tolerance.

The following letter code is to be used for indicating the standard Resistance Tolerance.

F=±1%                      J=±5%

8.4 8<sup>th</sup> to 11<sup>th</sup> digits: Resistance Value.

8.4.1 For the standard resistance values of E-24 series, the 8<sup>th</sup> digit is "0",the 9<sup>th</sup> & 10<sup>th</sup> digits are to denote the significant figures of the resistance and the 11<sup>th</sup> digit is the number of zeros following;

For the standard resistance values of E-96 series, the 8<sup>th</sup> digit to the 10<sup>th</sup> digits is to denote

Approved	Checked	Prepared	File NO.	Edition	Date	Page
William Zhao	Ted Hsu	Chengxia Tang	JLC-01-013	1	2017/05/09	9 / 12



the significant figures of the resistance and the 11<sup>th</sup> digit is the zeros following.

8.4.2 The following numbers and codes are to be used to indicate Power of ten in the 11<sup>th</sup> digit:

0=10<sup>0</sup>    1=10<sup>1</sup>    2=10<sup>2</sup>    3=10<sup>3</sup>    4=10<sup>4</sup>    5=10<sup>5</sup>  
6=10<sup>6</sup>    J=10<sup>-1</sup>    K=10<sup>-2</sup>    L=10<sup>-3</sup>    M=10<sup>-4</sup>

8.5 12<sup>th</sup>~14<sup>th</sup> digits.

8.5.1 12<sup>th</sup> digit: Packaging Type

C=Bulk in (Chip Product)

T=Tape/Reel

8.5.2 13<sup>th</sup> digit: Packing Quantity

1=1000pcs    2=2000pcs    3=3000pcs    4=4000pcs  
5=5000pcs    C=10000pcs    D=20000pcs    E=15000pcs

Chip Product:

BD=B/B-20000pcs    TC=T/R-10000pcs

8.5.3 14<sup>th</sup> digit:

Special features of additional information with the following codes:

E: Environmental Protection, Lead Free type.

S: Special features, such as: Embossed tape, different marking requirement, etc.

### 9.0 Order procedure: (Example: HP06 1/2W ±1% 75Ω T/R-5000)

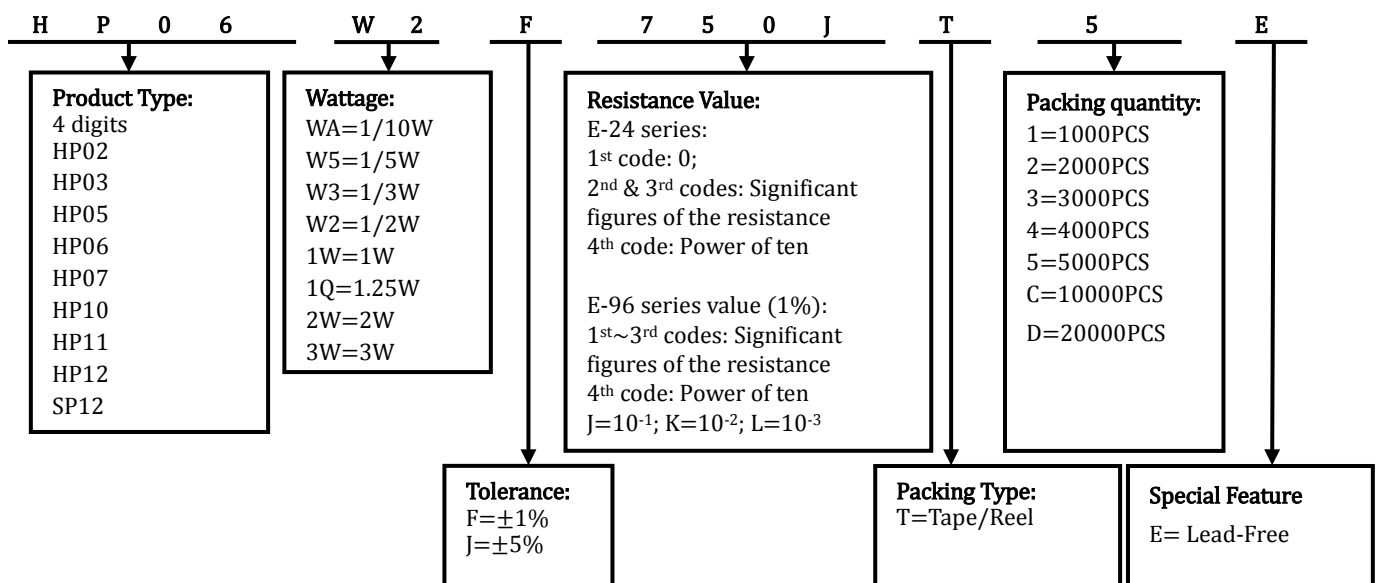

Approved	Checked	Prepared	File NO.	Edition	Date	Page
William Zhao	Ted Hsu	Chengxia Tang	JLC-01-013	1	2017/05/09	10 / 12



## 10.0 Packaging

### 10.1 Tapping dimension:

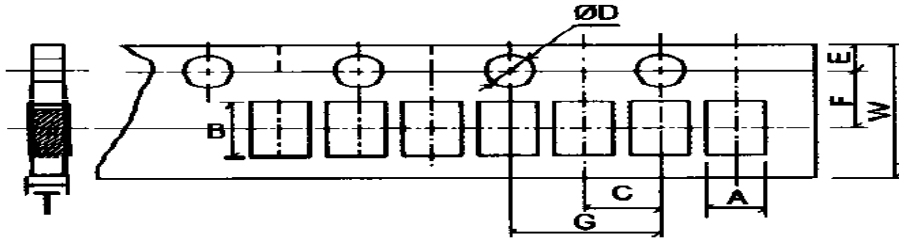

Unit: mm

Type	A	B	C±0.05	$\phi D$ +0.1 -0	E±0.1	F±0.05	G±0.1	W±0.2	T±0.1
HP02	0.65±0.20	1.15±0.20	2.00	1.50	1.75	3.50	4.00	8.00	0.45

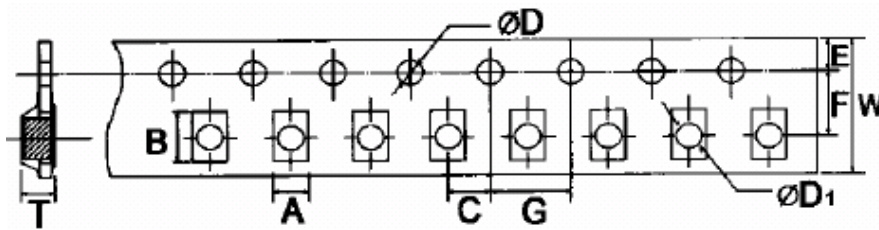

Unit: mm

TYPE	A±0.2	B±0.2	C±0.05	$\phi D$ +0.1	E±0.1	F±0.05	G±0.1	W±0.2	T±0.10
HP03	1.10	1.90	2.00	1.50	1.75	3.50	4.00	8.00	0.67
HP05	1.65	2.40	2.00	1.50	1.75	3.50	4.00	8.00	0.81
HP06	2.00	3.60	2.00	1.50	1.75	3.50	4.00	8.00	0.81
HP07	2.80	3.50	2.00	1.50	1.75	3.50	4.00	8.00	0.75
HP10	2.80	5.40	2.00	1.50	1.75	5.50	4.00	12.00	0.75
HP11	3.50	4.80	2.00	1.50	1.75	5.50	4.00	12.00	1.00
HP12	3.50	6.70	2.00	1.50	1.75	5.50	4.00	12.00	1.00

Approved	Checked	Prepared	File NO.	Edition	Date	Page
William Zhao	Ted Hsu	Chengxia Tang	JLC-01-013	1	2017/05/09	11 / 12



10.2 Reel dimension:

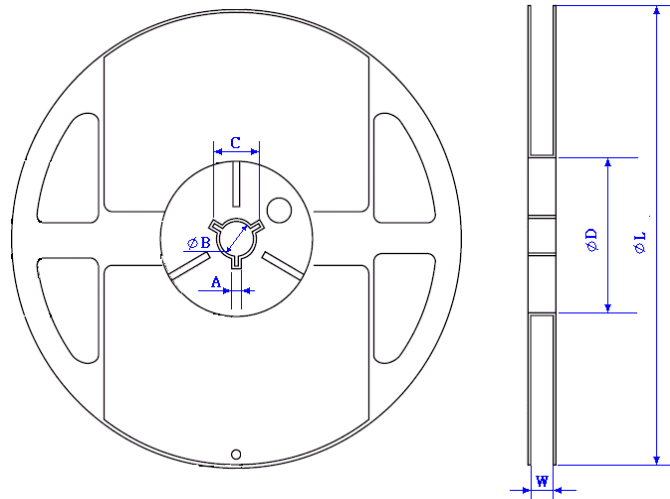

Unit: mm

Type	Taping	Size	A±0.5	B±0.5	C±0.5	ΦD±1	ΦL±2	W±1
HP02	Paper	10,000pcs reel	2.0	13.0	21.0	60.0	178.0	10.0
HP03	Paper	5,000pcs reel	2.0	13.0	21.0	60.0	178.0	10.0
HP05	Paper	5,000pcs reel	2.0	13.0	21.0	60.0	178.0	10.0
HP06	Paper	5,000pcs reel	2.0	13.0	21.0	60.0	178.0	10.0
HP07	Paper	5,000pcs reel	2.0	13.0	21.0	60.0	178.0	10.0
HP10	Paper or Embossed	4,000pcs reel	2.0	13.0	21.0	60.0	178.0	13.8
HP11	Embossed	4,000pcs reel	2.0	13.0	21.0	60.0	178.0	13.8
HP12	Embossed	4,000pcs reel	2.0	13.0	21.0	60.0	178.0	13.8

**11.0 Note:**

11.1 UNIOHM recommends the storage condition:

11.1.1 Temperature: 15°C~35°C

11.1.2 Humidity: 25%~75%.

Even under storage condition above-mentioned, resistors' solderability still degrades day by day.

11.2 Store / delivery cartons must be put by correct direction; otherwise product will crack or bent.

11.3 Product performance and soldered connections may deteriorate if the products stored in the following place:

11.3.1 In high electrostatic

11.3.2 In direct sunshine, rain, snow or condensation

11.3.3 Exposed to sea winds or corrosive gases, including Cl<sub>2</sub>, H<sub>2</sub>S, NH<sub>3</sub>, SO<sub>2</sub>, and NO<sub>2</sub>.

Approved	Checked	Prepared	File NO.	Edition	Date	Page
William Zhao	Ted Hsu	Chengxia Tang	JLC-01-013	1	2017/05/09	12 / 12