

## ■ AEC-Q200 Chip Resistor— QR Series (Wide Terminal Type)



### ■ Application

- Automotive electronics
- Navigation equipment
- Power supply , ECU etc.
- Indoor lighting, Central door locking, Wiper module

### ■ Features

- Small size and light weight
- Reduction of assembly costs and matching with placement machines
- Reliability, high quality and fast delivery
- Chip resistor of the wide terminal type.

### ■ Standard Electrical Specifications

Item Type	Rated Power at 70°C	Max Working Voltage	Max Overload Voltage	T.C.R. (PPM/°C)	Resistance Range	
					F(±1%)	J(±5%)
QR0612	0.75 W	200V	400V	±100	10Ω~3.3KΩ	10Ω~3.3KΩ
				±100	3.6KΩ~1MΩ	3.6KΩ~1MΩ

● Operating Temperature Range : -55°C ~ +155°C.

## ■ Type Dimension- Chip Resistor

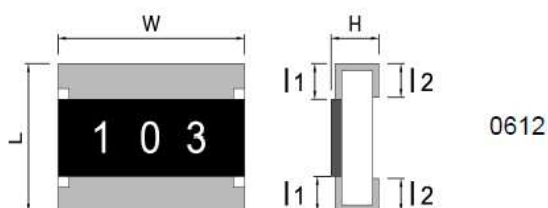

### ■ Dimension

Unit: mm

TYPE	L	W	H	l <sub>1</sub>	l <sub>2</sub>
QR0612	1.60 ± 0.15	3.20 ± 0.15	0.60 ± 0.10	0.30 ± 0.20	0.45 ± 0.15

■ Parts Number Explanation

■ Example:

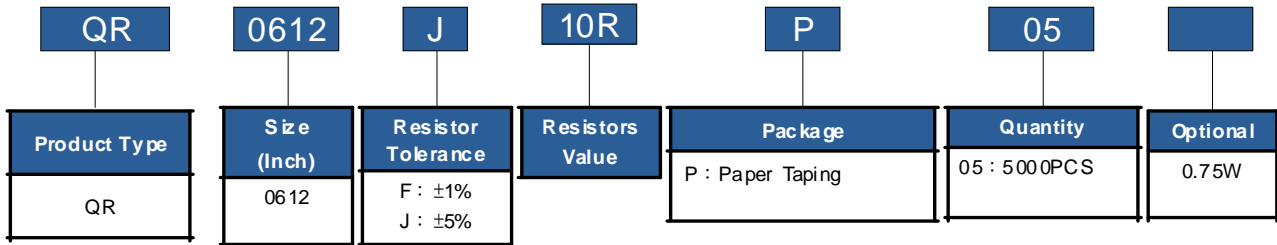

■ Appendix For SMD Chip Resistor

● Packaging Information

◆ For All Series

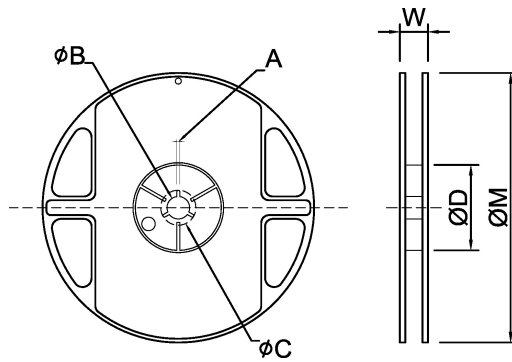

■ Dimension

Unit: mm

TYPE	SIZE		A	φB	φC	φD	W	φM
QR0612	7"	5K/Reel	2.0±0.5	13.5±1.0	21±1.0	60±1.0	11.5±2.0	178±2.0

■ Tapping Specification

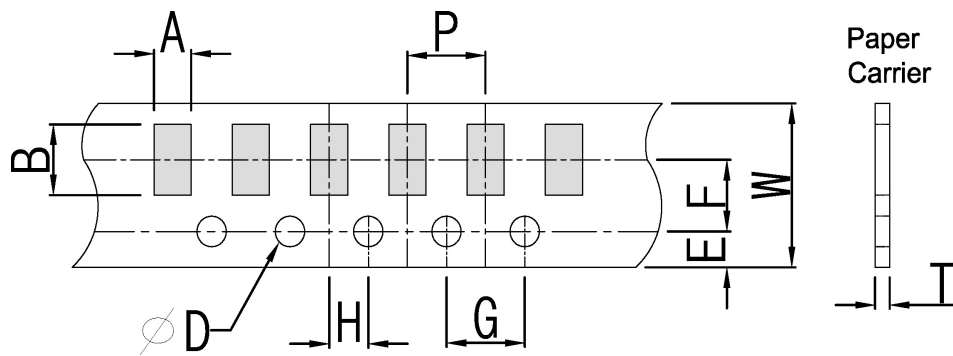

■ Dimension

Unit: mm

Packaging	Type	A	B	W	E	F	G	H	T	$\phi D$	P
Paper Type	QR0612	1.90±0.2	3.50±0.2	8.0±0.2	1.75±0.1	3.5±0.05	4.0±0.1	2.0±0.05	0.75±0.1	1.50 +0.10 -0	4.0±0.1

■ Packing Material Data / Storage Data

■ Front & Back Lead Dimension

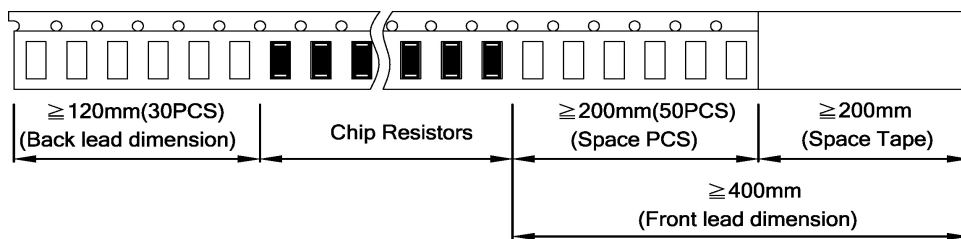

■ Top Adhesive Peel Off Strength : 10~70g

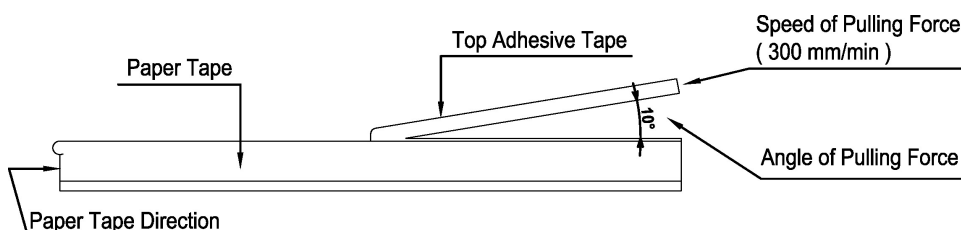

## ■ Package

Inner Box Size	
Reel	Size H(mm)
1	13
2	24
3	36
5	60
10	113

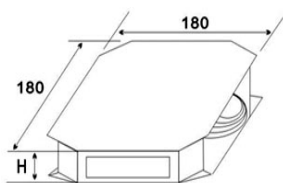

External Box Size			
Contain (Kpcs)	Length (mm)	Width (mm)	Height (mm)
25K	180	180	60
50K	180	180	110
150K	430	200	200
300K	400	400	200

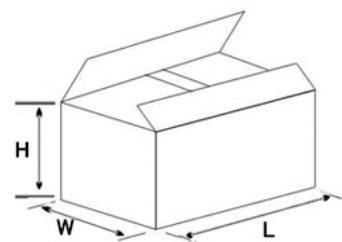

## ■ Storage Data :

Storage time at the environment temp:  $25\pm 5^{\circ}\text{C}$  & humidity:  $60\pm 20\%$  is valid for one year from the date of delivery.

## ● Reliability Test and Requirement

Test Item	Test Method	Procedure	Requirements
Temperature Coefficient of Resistance (T.C.R)	JIS C 5201-1 clause 4.8	$-55^{\circ}\text{C}$ or $+155^{\circ}\text{C}$ , $25^{\circ}\text{C}$ is the reference temperature	Refer to Ratings
Short Time Overload	JIS C 5201-1 clause 4.13	2.5 times RCWV or Max. Overload voltage whichever is less for 5 seconds.	1% : $\pm(1.0\%+0.05\Omega)$ 5% : $\pm(2.0\%+0.10\Omega)$
Soldering Heat	JIS C 5201-1 clause 4.18	$260\pm 5^{\circ}\text{C}$ for 10 seconds.	1% : $\pm(0.5\%+0.05\Omega)$ 5% : $\pm(1.0\%+0.05\Omega)$
Temperature Cycling	JIS C 5201-1 clause 4.19	$-55^{\circ}\text{C}$ to $+155^{\circ}\text{C}$ , 5 cycles	1% : $\pm(0.5\%+0.05\Omega)$ 5% : $\pm(1.0\%+0.10\Omega)$
Load Life in Humidity	JIS C 5201-1 clause 4.24	$40\pm 2^{\circ}\text{C}$ , 90~95% R.H. RCWV or Max. working voltage for 1000 hrs with 1.5 hrs "ON" and 0.5 hr "OFF" .	1% : $\pm(0.5\%+0.05\Omega)$ 5% : $\pm(2.0\%+0.05\Omega)$
Load Life (Endurance)	JIS C 5201-1 clause 4.25	$70\pm 2^{\circ}\text{C}$ , RCWV or Max. working voltage for 1000 hrs with 1.5 hrs "ON" and 0.5 hr "OFF" .	1% : $\pm(1.0\%+0.05\Omega)$ 5% : $\pm(3.0\%+0.10\Omega)$
Terminal Bending Strength	JIS C 5201-1 clause 4.33	Bending once for 5 seconds D : 0612 = 2mm	$\pm 1$ : $\pm(1.0\%+0.05\Omega)$ $\pm 5$ : $\pm(1.0\%+0.05\Omega)$

## AEC-Q200 test

Test Item	Test Method	Procedure	Requirements
Temperature Cycling	JESD22 Method JA-104	1000 Cycles (-55°C to +125°C) Measurement at 24±4 hours after test conclusion.	1% : ±(0.5%+0.05 Ω) 5% : ±(1.0%+0.10 Ω)
Resistance to Solvent	MIL-STD-202 Method 215	Add Aqueous wash chemical-OKEM clean or equivalent.	1% : ±(0.5%+0.05 Ω) 5% : ±(0.5%+0.05 Ω)
Biased Humidity	MIL-STD-202 Method 103	1000 hours 85°C/85%RH.	1% : ±(0.5%+0.05 Ω) 5% : ±(2.0%+0.05 Ω)
High Temperature Exposure (Storage)	MIL-STD-202 Method 108	1000 hrs. @ T=125°C.	1% : ±(0.5%+0.05 Ω) 5% : ±(2.0%+0.05 Ω)
Operation Life	MIL-STD-202 Method 108	125°C or Max.working voltage for 1000 hrs with 1.5 hrs"ON" and 0.5hr "OFF"	1% : ±(1.0%+0.05 Ω) 5% : ±(3.0%+0.10 Ω)
External Visual	MIL-STD-883 Method 2009	Electrical test not required. Inspect device construction, marking and workmanship.	—
Mechanical Shock	MIL-STD-202 Method 213	Impact acceleration : 1500g Pulse duration : 0.5ms Number of shocks : 30 shocks(5 shocks for each face)	1% : ±(1.0%+0.05 Ω) 5% : ±(2.0%+0.10 Ω)
Vibration	MIL-STD-202 Method 204	5 g's for 20min., 12 cycles each of 3 orientations.	1% : ±(1.0%+0.05 Ω) 5% : ±(2.0%+0.10 Ω)
ESD	ACE-Q200- 002 or ISO/DIS 10605	0612 : 1KV	For the product %
Solderability	J-STD-002	(1) 4 hrs 155°C dry heat (2) 260±5°C 10 sec.	1% : ±(0.5%+0.05 Ω) 5% : ±(1.0%+0.05 Ω)
Board Flex	AEC Q200-005	Beading once for 60 seconds	1% : ±(1.0%+0.05 Ω) 5% : ±(1.0%+0.05 Ω)

## ● General Information

### ■ Recommend Land Pattern Design ( For Reflow Soldering )

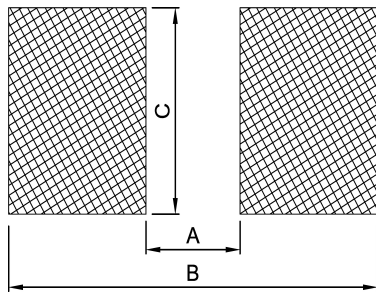

### ■ Dimension

Unit: mm

Item	Type	0612
A		0.70
B		2.30
C		3.20

### ■ Performance Characteristics

#### ■ Power Derating Curve

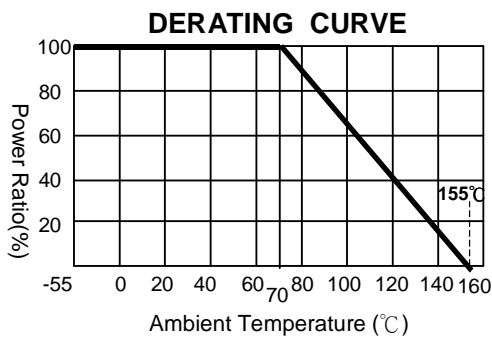

Power rating or current rating is in the case based on continuous full-load at ambient temperature of 70°C. For operation at ambient temperature in excess of 70°C, the load should be derated in accordance with figure of derating Curve.

#### ■ Voltage Rating or Current Rating

Resistance Range:  $\geq 1 \Omega$

Rated Voltage: The resistor shall have a DC continuous working voltage or a RMS AC continuous working voltage at commercial-line frequency and wave form corresponding to the power rating, as determined formula as following:

$$E(RCWV) = \sqrt{P \times R}$$

E=Rated voltage(V)  
P=Power rating(W)  
R=Nominal resistance( $\Omega$ )

#### ■ Soldering Profile

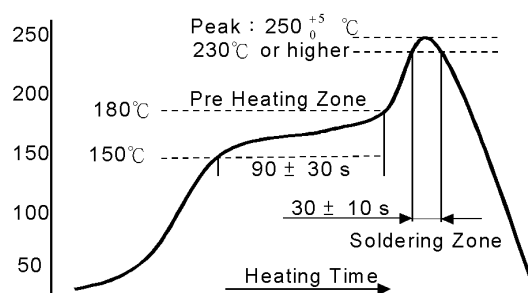

■ Equipments Applicable:

Our company's products are produced under low temperature processing applicable to IR reflow surface mounting devices. It is comparatively not applicable to wave soldering which will possibly cause the risk ablating the element protection layer and the front conductor and cause the drift of the resistance value and ablation of the markings.

■ Product Testing Method:

Our products are tested with our company's tapping & testing equipments by using four-feet probe to touch at the back of both electrodes. Supposed different testing points or methods are requested, please advise beforehand and customized-made production is available.