

RoHS

MAPX

MODIFICATION

DATE

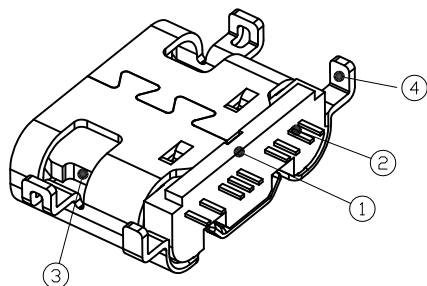
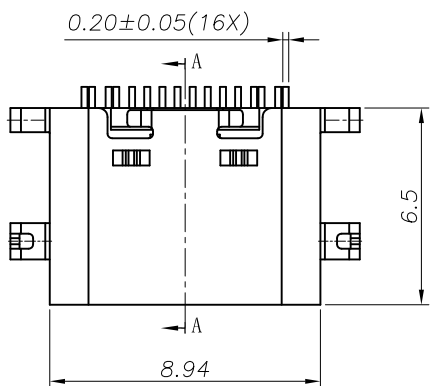

NOTE:

- 1.MATERIAL SPECIFICATION:
 - 1.HOUSING:HIGH TEMPERATURE RESISTANT PLASTIC,UL94 V-0.
 - 2.CONTACTS:COPPER ALLOY
 - 3.MID PLATE: STAINLESS STEEL
 - 4.FRONT SHELL: STAINLESS STEEL
- 2.PLATING SPECIFICATION:
 - 2-1.CONTACTS:
 - Ni 50u" MIN. UNDER PLATED OVER ALL.
 - Au PLATED ON THE FUNCTIONAL AREA OF CONTACT.
 - (GOLD PLATING THICKNESS FOLLOW THE P/N)
 - PLATING SPECIFICATIONS OF THE SOLDER AREA FOLLOW THE P/N
 - 2-2.FRONT SHELL:
 - Ni 30u" MIN. UNDER PLATED OVER ALL.
 - 2-3.MID PLATE:
 - CLEAR ONLY
- 3.MECHANICAL PERFORMANCE,
 - 3-1.INSERTION FORCE: 0.5~2.0kgf.
 - 3-2.REMOVAL FORCE: 0.8kgf~2.0kgf.
 - 3-3.DURABILITY: 10000 CYCLES.
- 4.ELECTRICAL PERFORMANCE,
 - 4-1. CURRENT RATING:5.0A
VOLTAGE RATING:5.0V
 - 4-2. LLCR:
 - VBUS & GND PINS AND OTHER PINS: 40mΩ/PIN MAX.
 - SHIELD: 50mΩ/MAX.
 - LLCR MAX. CHANGE OF ALL PINS: 10mΩ.
 - 4-3.INSULATION RESISTANCE: 100MΩ MIN
 - 4-4.DIELECTRIC WITHSTAND VOLTAGE,AC 100V FOR 1 MINUTE.
5. ENVIRONMENTAL PERFORMANCE:
 - OPERATING TEMPERATURE: -25°C~+85°C.
- 6.IR REFLOW:
 - THE PEAK TEMPERATURE ON THE BOARD SHALL BE MAINTAINED FOR 10 SECONDS AT 260°C.

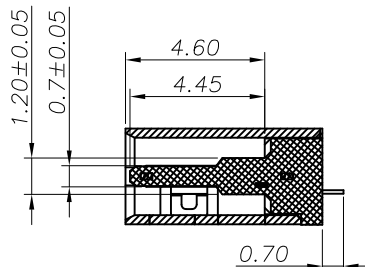
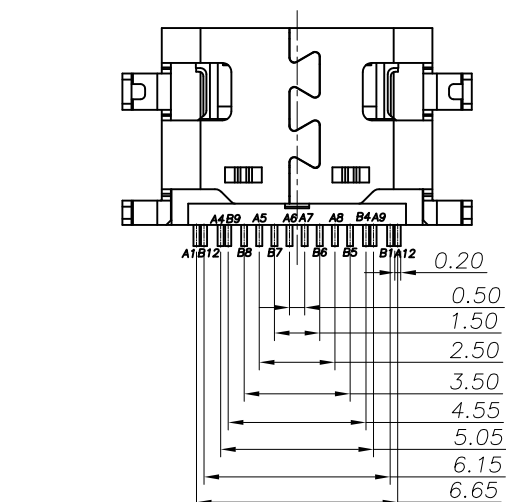
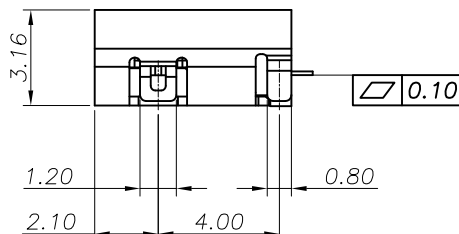
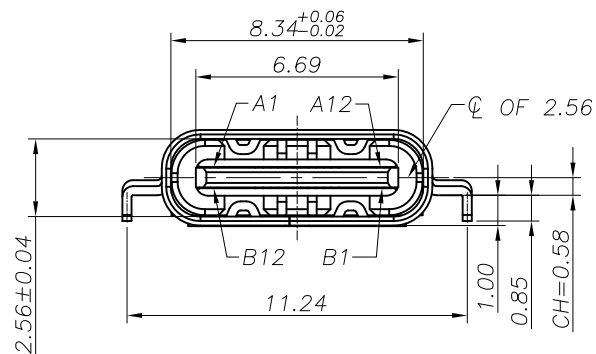

SECTION:A-A

产品图 PRODUCT CHART DWG		深圳市精拓金电子有限公司							
公差一览表 TOLERANCE UNLESS OTHERWISE		单位 UNITS	MM	制图 DRAWING	Gavin	制图料号 PRODUCT PART NO.			
X.	±0.35	X.	±5°	比例 SCALE	1:1	审核 CHKD	郭治富	产品名称 PRODUCT NAME	USB CF 16PIN (L=6.5)
.XX	±0.20	.XX	±2°	日期 DATE	2016-09-09	核准 APPD	黄国荣	角法 VIEW	MID MOUNT CH=0.58
.XXX	±0.10	.XXX	±1°					版本 VER	AD
	±0.05		±0.5°						

RoHS

MAPX

MODIFICATION

DATE

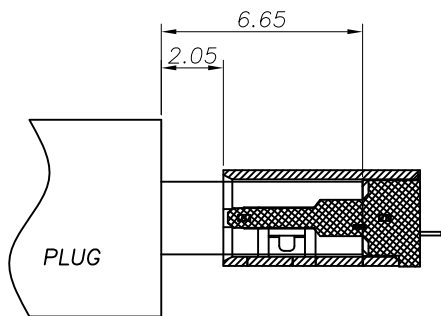

AFTER MATING

USB TYPE-C PIN ASSIGNMENTS

PIN NUMBER	SIGNAL NAME	PIN NUMBER	SIGNAL NAME
A1	GND	B12	GND
A4	VBUS	B9	VBUS
A5	CC1	B8	SBU2
A6	Dp1	B7	Dn2
A7	Dn1	B6	Dp2
A8	SBU1	B5	CC2
A9	VBUS	B4	VBUS
A12	GND	B1	GND

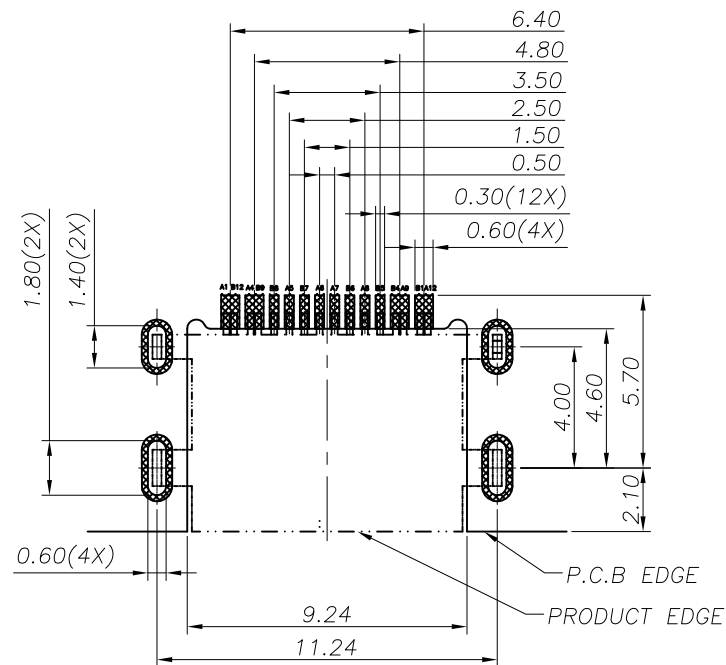

RECOMMENDED PCB LAYOUT(TOP VIEW)
THICKNESS 0.80MM;DEFAULT TOLERANCE:±0.05

产品图
PRODUCT CHART DWG

深圳市精拓金电子有限公司

公差一览表 TOLERANCE UNLESS OTHERWISE				单位 UNITS	MM	制图 DRAWING	Gavin	制图料号 PRODUCT PART NO.
X.	±0.35	X.	±5.°	比例 SCALE	1:1	审核 CHKD	郭治富	产品名称 PRODUCT NAME
.X	±0.20	.X	±2.°	日期 DATE	2016-09-09	核准 APPD	黄国荣	角法 VIEW
.XX	±0.10	.XX	±1.°					版本 VER
.XXX	±0.05	.XXX	±0.5°					AD

USB CF 16PIN (L=6.5)
MTD MOUNT CH=0.58

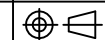

版本
VER

AD

RoHS

MAPX

MODIFICATION

DATE

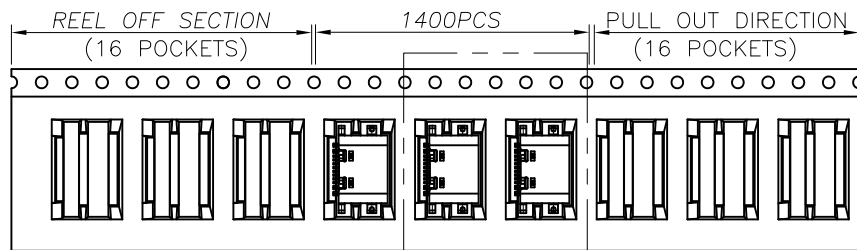

SEE DETAIL X

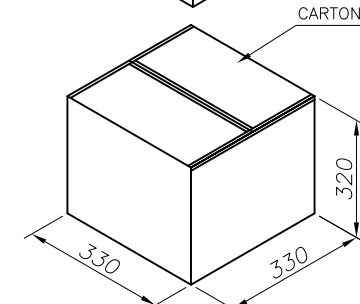
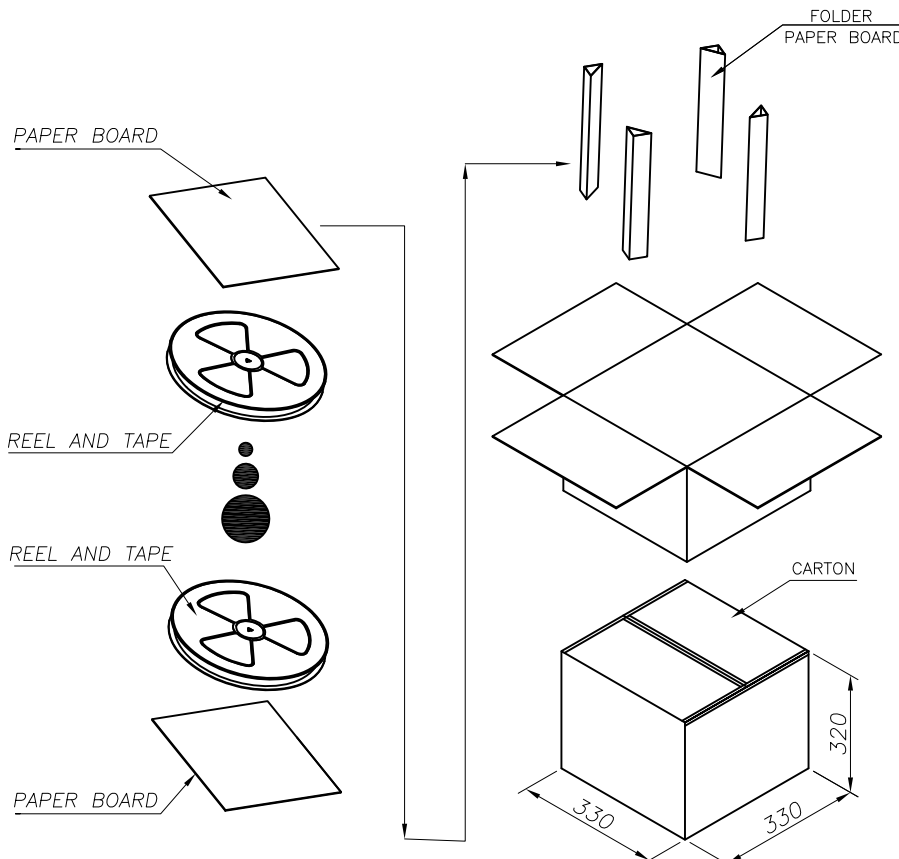
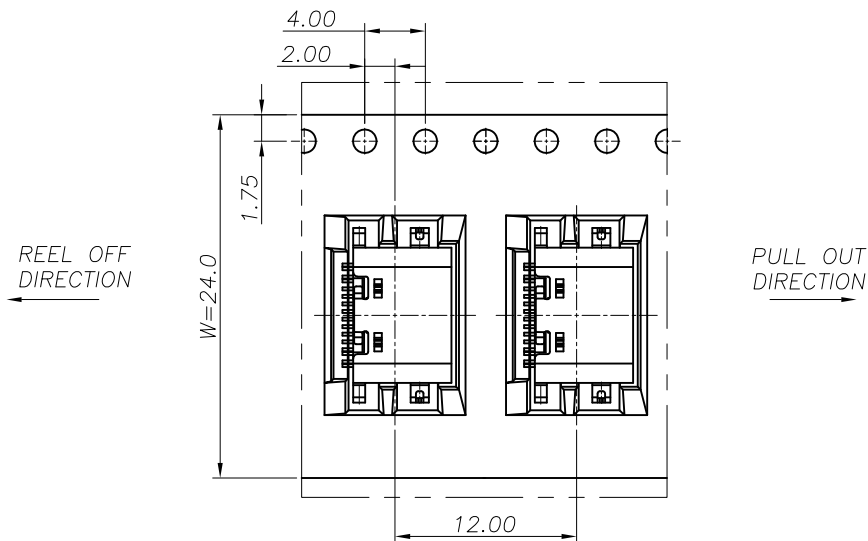
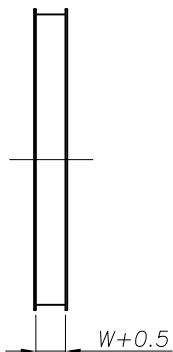
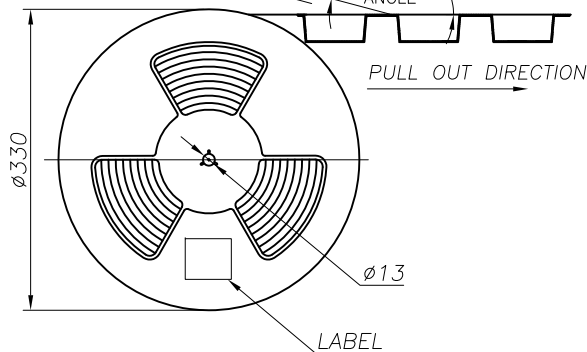
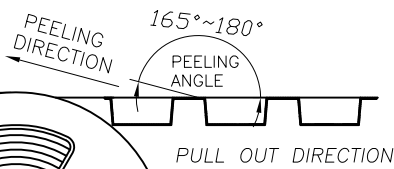

<p>产品图 PRODUCT CHART DWG</p> <p>公差一览表 TOLERANCE UNLESS OTHERWISE</p>				<p>深圳市精拓金电子有限公司</p>						
X.	±0.35	X.	±5.°	单位 UNITS	MM	制图 DRAWING	Gavin	制图料号 PRODUCT PART NO.		
.X	±0.20	.X	±2.°	比例 SCALE	1:1	审核 CHKD	郭治富	产品名称 PRODUCT NAME	USB CF 16PIN (L=6.5) MTD MOUNT CH=0.58	
.XX	±0.10	.XX	±1.°	日期 DATE	2016-09-09	核准 APPD	黄国荣	角法 VIEW	版本 VER	AD
.XXX	±0.05	.XXX	±0.5°							