

MAPX	MODIFICATION	DATE

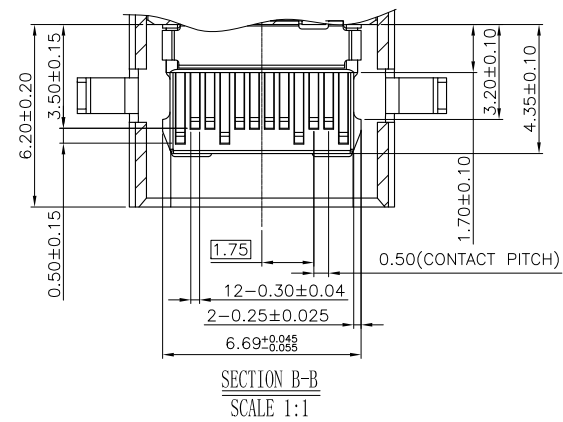

- NOTES:
- MATERIAL:
MOLDING: LCP UL94 V-0
CONTACT: COPPER ALLOY.
GOLD PLATED ON CONTACT AREA, 100u"
Min TIN (LEAD FREE) ON SOLDER AREA,
SHELL: SUS304-H, T=0.30±0.03mm
50u" NICKEL PLATING OVER ALL.
SHILD: SUS304-H, T=0.12±0.03mm
 - MECHANICAL:
INSERTION: 5~20N.
EXTRACTION: 8~20N.
DURABILITY: 10000 CYCLES
 - ELECTRICAL:
CURRENT: 5A MIN FOR VBUS;
0.25A MIN FOR OTHER.
VOLTAGE: 5VAC MAX
WITHSTANDING VOLTAGE: 100V AC.
CONTACT RESISTANCE: 40mΩ MAX.
INSULATION RESISTANCE: 100MΩ MIN.
 - ENVIRONMENTAL
TEMPERATURE RANGE -55°C ~ +85°C

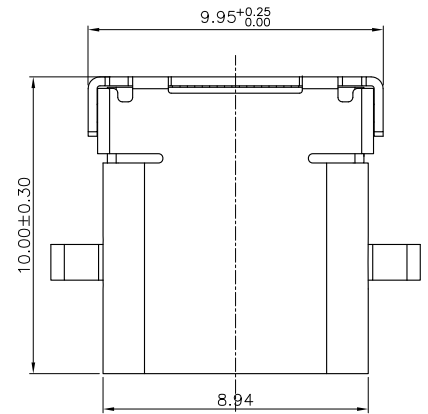
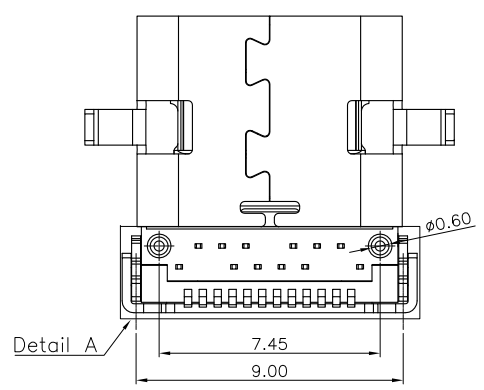
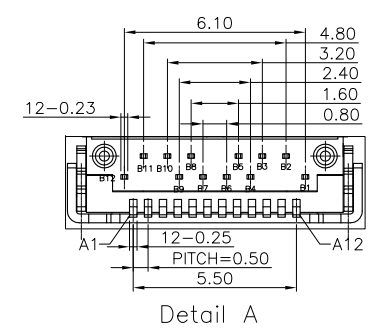
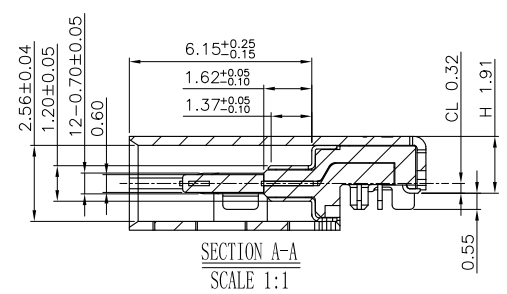
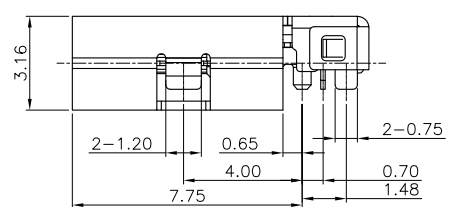
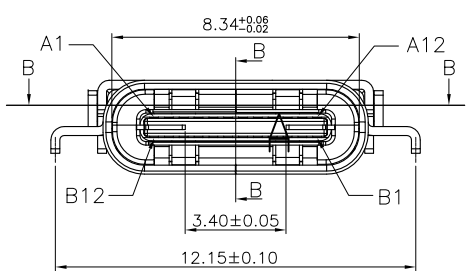

产品图 PRODUCT CHART DWG				深圳市精拓金电子有限公司				
公差一览表 TOLERANCE UNLESS OTHERWISE				单位 UNITS	MM	制图 DRAWING	Z-Y-B	制图料号 PRODUCT PART NO.
X.	±0.25	X.	±5.°	比例 SCALE	1:1	审核 CHKD		产品名称 PRODUCT NO.
.X	±0.20	.X	±2.°	日期 DATE	2014.05.15	核准 APPD		角法 VIEW
.XX	±0.15	.XX	±1.°					版本 VER
.XXX	±0.10	.XXX	±0.5°					AO

USB 3.1 C TYPE FEMALE SINK CONNECTOR SMT+DIP

MAPX	MODIFICATION	DATE

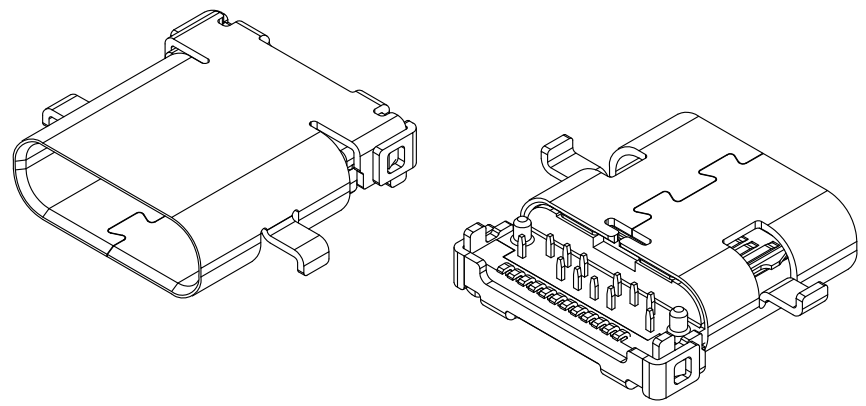

USB TYPE-C FULL-FEATURED RECEPTACLE INTERFACE PIN ASSIGNMENTS

PIN	Signal Name	Description	PIN	Signal Name	Description
A1	GND	Ground return	B12	GND	Ground return
A2	SSTXp1	Positive half of first SuperSpeed TX differential pair	B11	SSTXp1	Positive half of first SuperSpeed TX differential pair
A3	SSTXn1	Negative half of first SuperSpeed TX differential pair	B10	SSTXn1	Negative half of first SuperSpeed TX differential pair
A4	VBUS	Bus Power	B9	VBUS	Bus Power
A5	CC1	Configuration Channel	B8	CC1	Configuration Channel
A6	Dp1	Positive half of the USB 2.0 differential pair-Position 1	B7	Dp1	Positive half of the USB 2.0 differential pair-Position 1
A7	Dn1	Negative half of the USB 2.0 differential pair-Position 1	B6	Dn1	Negative half of the USB 2.0 differential pair-Position 1
A8	RFU1	Reserved for Future Use (RFU)	B5	RFU1	Reserved for Future Use (RFU)
A9	VBUS	Bus Power	B4	VBUS	Bus Power
A10	SSRXn2	Negative half of second SuperSpeed RX differential pair	B3	SSRXn2	Negative half of second SuperSpeed RX differential pair
A11	SSRXp2	Positive half of second SuperSpeed RX differential pair	B2	SSRXp2	Positive half of second SuperSpeed RX differential pair
A12	GND	Ground return	B1	GND	Ground return

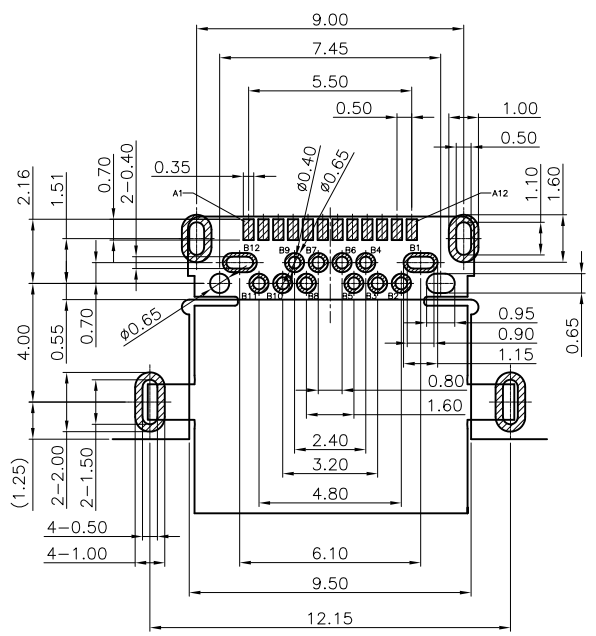

RECOMMEND P.C.B LAYOUT (COMPONENT SIDE)
 TOLERANCE FOR PCB LAYOUT IS ±0.05
 KEEP OUT AREA

产品图 PRODUCT CHART DWG		深圳市精拓金电子有限公司					
公差一览表 TOLERANCE UNLESS OTHERWISE		单位	MM	制图	Z-Y-B	制图料号	
X.	±0.25	X.	±5.°	比例	1:1	产品名称	
.X	±0.20	.X	±2.°	日期	2014.05.15	角法	
.XX	±0.15	.XX	±1.°	日期	2014.05.15	版本	
.XXX	±0.10	.XXX	±0.5°	日期	2014.05.15	版本	
		UNIT	MM	DRAWING	Z-Y-B	PRODUCT PART NO.	
		SCALE	1:1	CHECK		PRODUCT NO.	
		DATE	2014.05.15	APPD		角法	
						版本	
						AO	

USB 3.1 C TYPE FEMALE SINK CONNECTOR SMT+DIP

MAPX	MODIFICATION	DATE

A
B
C
D
E
F
G

A
B
C
D
E
F
G

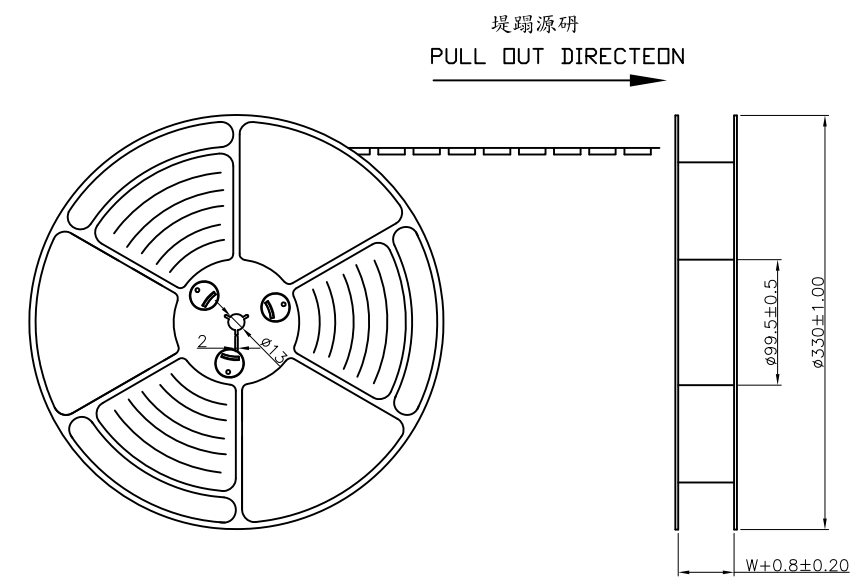

NOTES

1. 越詢 擇僅
LEAD TAPE LENGTH
提脚源研
PULL OUT DIRECTEON

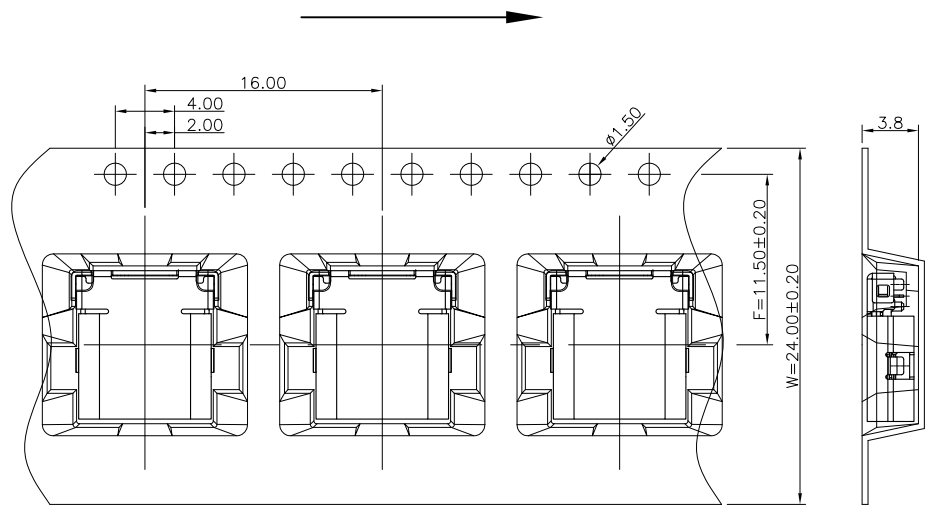
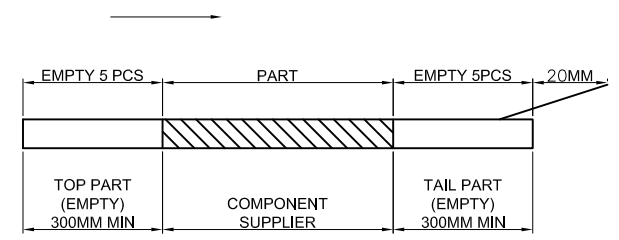

2. 效 ?薯薯 $\square 0.1 \sim 1.3N(10.2gf \sim 130gf)$

- PEELING OFF FORCE OF TOP TAPE: $0.1 \sim 1.3N(10.2gf \sim 130gf)$
 提?綫?綫最箆陪偶軋碼□
 THIS REQUIREMENT SHOULD BE APPLIED AT SHIPMENT□
 橙 婁綫?綫最箆祥夔?夔
 PEELING OFF SHOULD NOT BE ALLOWED DURING TRANSPORTATION

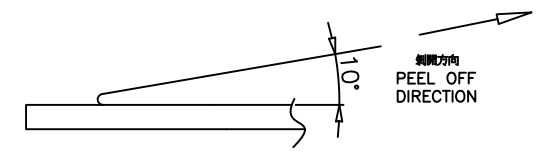

产品图 PRODUCT CHART DWG				深圳市精拓金电子有限公司				
公差一览表 TOLERANCE UNLESS OTHERWISE				单位 UNITS	MM	制图 DRAWING	Z-Y-B	制图料号 PRODUCT PART NO.
X.	± 0.25	X.	$\pm 5.^\circ$	比例 SCALE	1:1	审核 CHKD		产品名称 PRODUCT NO.
.X	± 0.20	.X	$\pm 2.^\circ$	日期 DATE	2014.05.15	核准 APPD		角法 VIEW
.XX	± 0.15	.XX	$\pm 1.^\circ$					版本 VER
.XXX	± 0.10	.XXX	$\pm 0.5^\circ$					AO

1 2 3 4 5 6 7 8 9 10

MAPX	MODIFICATION	DATE

at small positioning hole of the carrier tape side).
 標籤黏貼處 (朝捲裝包材的小定位孔一側)
 Location of label sticking (label)

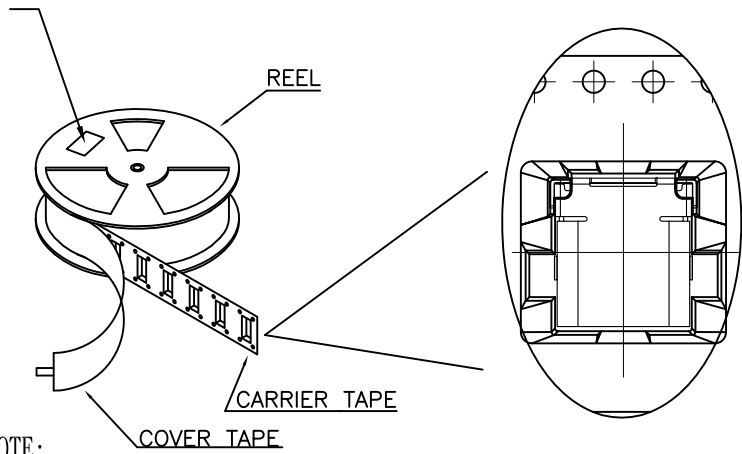
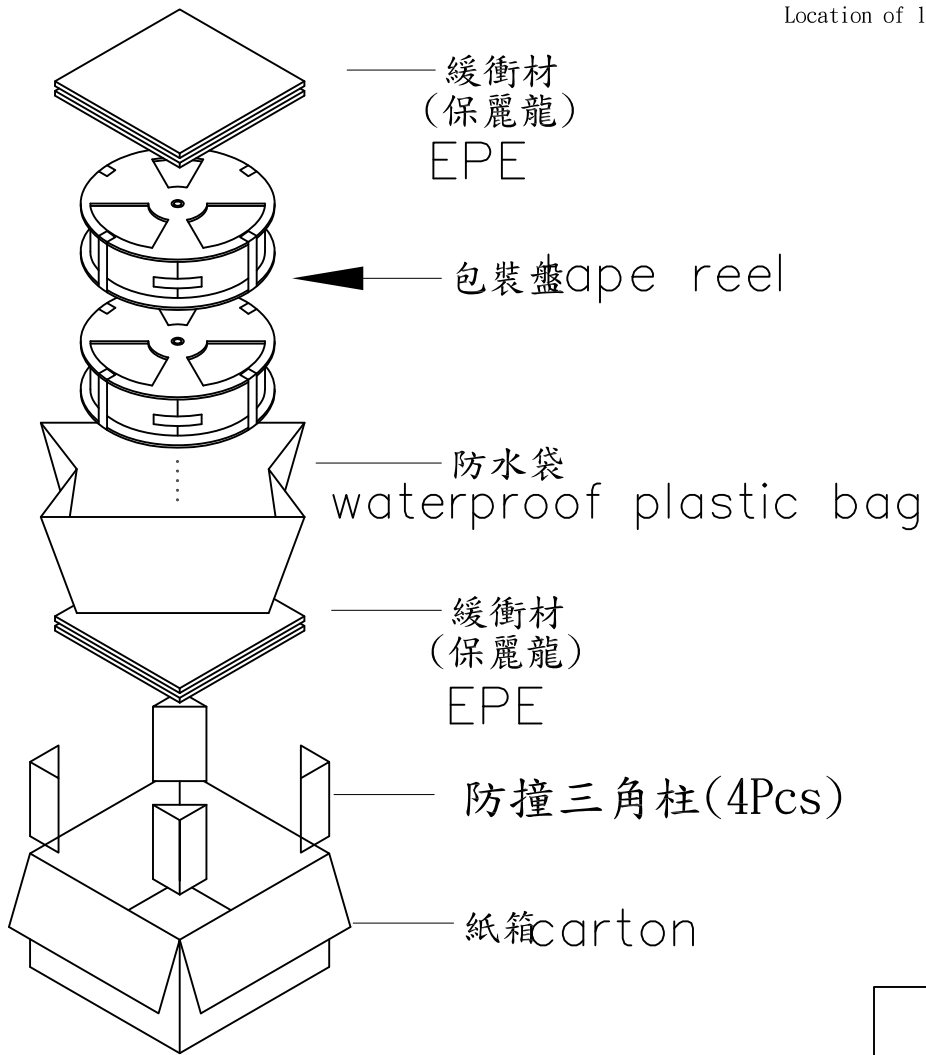

NOTE:
 1. 潘 婦規 講摯潘眊規眊 講 x0恒桶跡.
 (Packing q' ty of each reel & carton as below
 (table shown).
 2. 眊眊糯 葡企恒婦規 ?婦規 婦規
 Use cover tape to cover and hot melt
 machine to seal up.
 3. 潘??眊溫??逆鉄蹬
 Every carton use 2pcs EPE.
 4. 規 家 腔橙履溫 ?眊甜眊糯 猾詣
 Put reels in the carton and use
 adhesive tape to seal up.

产品图 PRODUCT CHART DWG				深圳市精拓金电子有限公司						
公差一览表 TOLERANCE UNLESS OTHERWISE				单位 UNITS	MM	制图 DRAWING	Z-Y-B	制图料号 PRODUCT PART NO.		
X.	±0.25	X.	±5.°	比例 SCALE	1:1	审核 CHKD		产品名称 PRODUCT NO.	USB 3.1 C TYPE FEMALE SINK CONNECTOR SMT+DIP	
.X	±0.20	.X	±2.°	日期 DATE	2014.05.15	核准 APPD		角法 VIEW	版本 VER	AO
.XX	±0.15	.XX	±1.°							
.XXX	±0.10	.XXX	±0.5°							