

目录 MAPX	设置内容 MODIFICATION	日期 DATE
------------	----------------------	------------

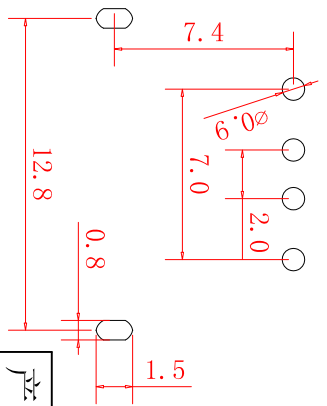
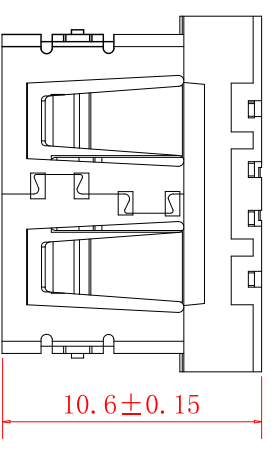
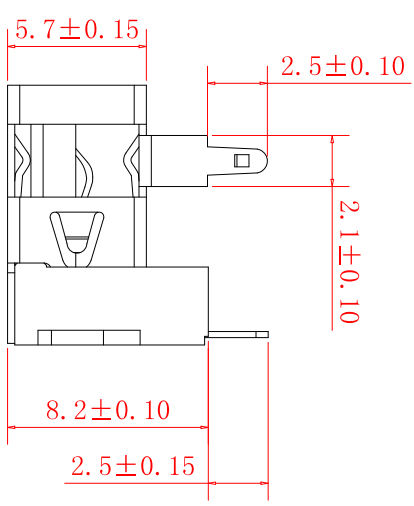
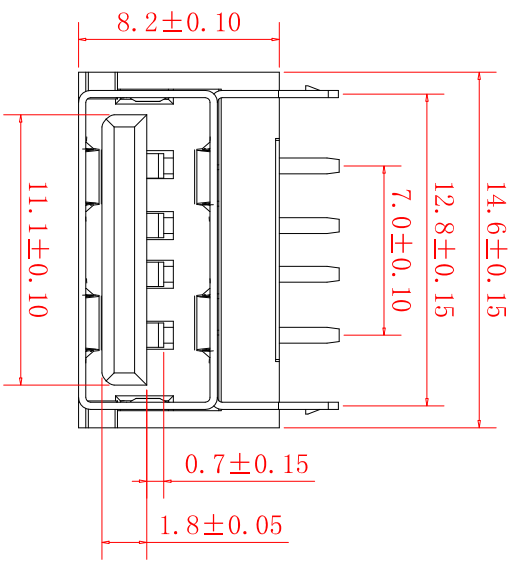
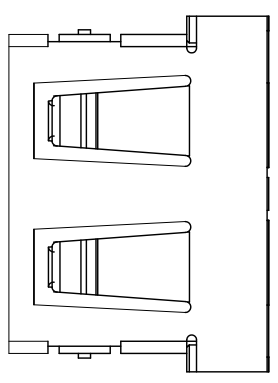
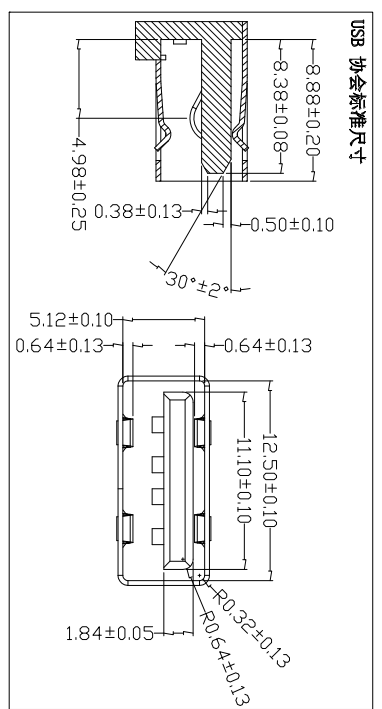

PCB LAYOUT

深圳市精拓金电子有限公司

- 特性: Specifications:**
电气: Electrical:
 1. 接触阻抗: Contact Resistance: 30 milliohms MAX
 2. 耐电压: Dielectric With Standing Voltage: 500 V AC AT Sea Level
 3. 绝缘阻抗: Insulation Resistance: 1000 MEGA ohms MIN
- 机构: Mechanical:**
 1. 结合力: Mating Force: 35 N MAX 最大 35 N
 2. 拔出力: Unmating Force: 8 N MIN 最少 8 N
- 材料: Material:**
 1. 塑胶: 黑色PBT.
 2. 端子: Contact: C2680, T=0.25±0.01
 3. 外壳: Shell: SPCC, T=0.3±0.01
- 电镀: Finish:**
 1. 端子: Contact: Plated Gold in Mating Area:
 Tin/Lead 0n Solder Tails. 接触点镀金1唛, 脚镀锡100唛
 2. 外壳: Shell:
 Nickel Plating . 镀镍80唛
 额定电流2.5A, 盐雾24H, 镀锡部分12H

公差表		公差表	
TOLERANCE		DIMENSIONS	
尺寸	A	B	±C
0-5	±0.02	±0.05	±0.1
5-10	±0.05	±0.1	±0.15
10-50	±0.1	±0.15	±0.2

未标注的公差按一按标准计算

单位	MM	制图	客户料号
UNITS		DRAWING	PRODUCT PART NO.
比例	1:1	审核	产品名称
SCALE		CHKD	PRODUCT NA.
日期	2014/04/23	核准	角法
DATE		APPD	角法
			版本
			VER
			A0