



韩国韩荣部品株式会社
东莞市韩荣电子科技有限公司

承认书

客 户 CUSTOMER			
客户料号 CUSTOMER MODEL:			
品 名 PART NAME	轻触开关		
型 号 MODEL	K2-1103DP		
承认单位 DEPT	检验 INSPECT (QC)	审核 CHECK (R&D)	批准 APPD (R&D)
责 任 人 RESPONSIBLE			
判 定 DETERMINE	OK <input type="checkbox"/> NG <input type="checkbox"/>	OK <input type="checkbox"/> NG <input type="checkbox"/>	OK <input type="checkbox"/> NG <input type="checkbox"/>

韩国韩荣部品株式会社

KOREAN HROPARTS ELECTRONICS CO.,LTD

ADD:118-4 Zhen Chen 3 Xin Buk Chun City Gang Won Do Korea

E-mail: hroparts@smtswitch.com

东莞市韩荣电子科技有限公司

DONGGUAN HRO ELECTRONICS TECHNOLOGY CO.LTD

TEL: 86-769-87818100 87818200 87818300

FAX: 86-769-87818500

Http:www.smtswitch.com

E-mail:sales@smtswitch.com

ADD: 中国广东省东莞市塘厦镇 138 工业区宏业北二横路 1 号

本厂工程部审核:

ENGINEERING DEPT:

东莞市韩荣电
子科技有限
公司工程部

日期: 年 月 日

RoHS

让客户 100%满意的高品质开关插座供应商

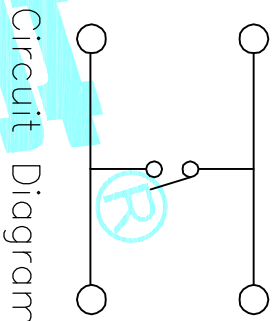
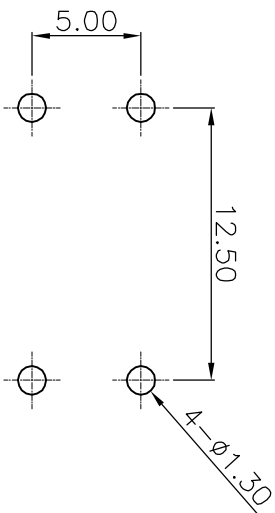
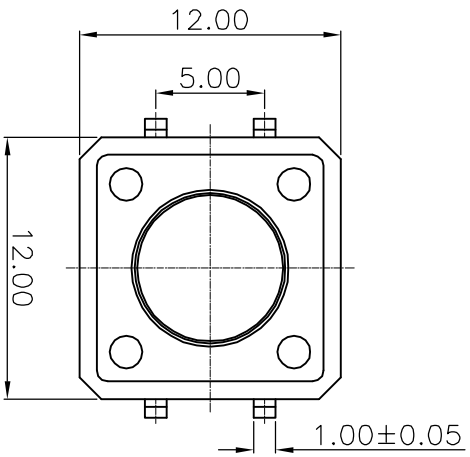

PCB Layout(Pattern side)

Circuit Diagram

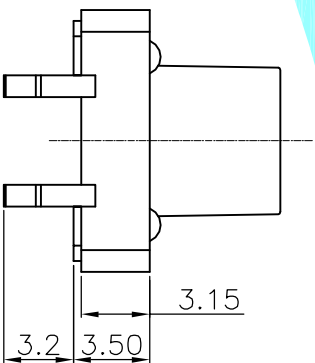
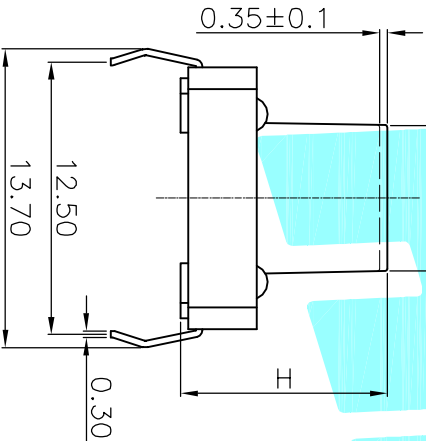

NO.1		NO.1	
PART NO	H	PART NO	H
A	4.3	O	11
B	4.5	P	11.5
C	5	Q	12
D	5.5	R	12.5
E	6	S	13
F	6.5	T	13.5
G	7	U	14
H	7.5	V	15
I	8	W	16
J	8.5	X	17
K	9	Y	18
L	9.5	Z	19
M	10		15.5
N	10.5		

NO.2	
PART NO	vigor
1	90±30
2	130±30
3	180±30
4	250±30
5	350±50

NO.3	
PART NO	MATERIAL/QTY
S	SUS/1PC
C	C5210/1PC
D	SUS/2PCS
F	C5210/2PCS

NO.4-NO.5	
PART NO	NOTE
01~99	SERIAL NUMBER

⑤	Terminal	—	4	Brass(0.3t)	Plating silver	
④	Contact	—	1	F.Ag/C5210	—	
③	Base	—	1	Nylon	Black UL94V-0	
②	Cover	—	1	SPCC/Bross	Plating Sn	
①	Keystoke	—	1	Nylon	Black UL94V-0	
ITEM	PART NAME	TER'NO.	QTY.	MATERIAL	FINISHING	REMARK

APPROVALS		DATE	
DRAWN	J.X.Zhang	DATE	2014/2/18

CHECKED		TITLE:	
APPROVALS		TACT SWITCHS	
TOLERANCES ARE	30~0.1± 10~0.30 5~10 ~5	±0.30 ±0.20 ±0.15 ±0.10	ANGLE UNIT: mm SCALE: 1:1
		±2'	DRAWING NO.
			PROJ. SHEET 1 OF 1

ECN NO.	REV.	DATE.	DESCRIPTION.	CHANGE.	CHECK.	APPRO.
	A		NEW			



ELECTRONICS CO.,LTD

 KOREAN HROPARTS ELECTRONICS CO.,LTD		文件编号 FILE NO.	HR-SPEC-001	页码 PAGE	1/5
		发布日期 DATE OF ISSUE	2016年10月09日		
PRODUCT SPECIFICATION 产品承认书		文件版本 EDITION	第 A 版 第 3 次修订		
Title 名称	轻触开关 TACT SWITCH	产品料号 PART NO.	轻触开关系列 I		

1. General specification 基本事项	
1.1 Switch action 开关种类:	轻触开关 TACT SWITCH
1.2 Switch rating 最大额定值 :	D. C. 12V , 50 mA
1.3 Operation temperature range 使用温度试验范围 :	- 25~ + 80°C
1.4 Preservative temperature range 保存温度范围 :	- 30~ + 85°C
1.5 Appearance and dimensions : 外形及尺寸 :	See outside drawing page 见外形尺寸图
1.6 General test condition (Tests and measurements shall be made under the following standard conditions unless otherwise specified): 正常测试条件(未有特殊说明量测在以下条件进行):	
Ambient temperature 温度:	5 ~ 35°C
Relative humidity 相对湿度:	45 ~ 85%RH
Air pressure 气压:	86 ~ 106kPa(860~1060mbar)
However, if doubt arises on the decision based on the measured Values under the above-mentioned conditions, the following conditions shall be employed: 但是在对判定产生疑义时,按下述状态实施:	
Ambient temperature 温度:	20±2°C
Relative humidity 相对湿度:	65±5%RH
Air pressure 气压:	86 ~ 106kPa(860~1060mbar)

2. Performance 性能	
2.1 Electrical characteristics 电气性能	

NO.	Item 项目	Test condition 试验条件	Performance 规格
2.1.1	Contact resistance 接触电阻	Push force: (Operation force) x 2. 测定时的负荷: 操作方向动作力基准值的2 倍。 Measurement tool : Contact resistance meter 测定器: 微电流接触电阻计(1kHz, 20mV, 5~50mA)	100mΩ MAX 100mΩ 以下
2.1.2	Insulation resistance 绝缘电阻	D. C. 100V(Between terminals) (端子间)	100MΩ min 100MΩ 以上
2.1.3	Withstand voltage 耐电压	A. C 500V for 1 min (Between terminals) (端子间)	No. insulation destruction. 无绝缘破坏

2.2 Mechanical Characteristics 机械性能	
--	--

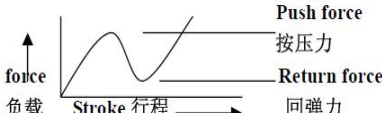
2.2.1	Operation force 动作力	Push by recommended operating condition. 按规定的操作条件施加压力 	Push force: See detail drawing page. 按压力: 见产品图纸
-------	---------------------	---	--

 KOREAN HROPARTS ELECTRONICS CO.,LTD		文件编号 FILE NO.	HR-SPEC-001	页码 PAGE	2/5
		发布日期 DATE OF ISSUE	2016 年 10 月 09 日		
PRODUCT SPECIFICATION 产品承认书		文件版本 EDITION	第 A 版 第 3 次修订		
Title 名称	轻触开关 TACT SWITCH	产品料号 PART NO.	轻触开关系列 I		

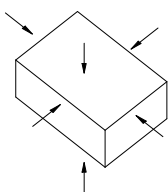
NO.	Item 项目	Test condition 试验条件	Performance 规格
2.2.2	Travel to closure 动作行程	Push by recommended operating condition.(4.2) F=(Operation force) x2 按规定的操作条件施加压力 F=动作力x2	See outside drawing page 见外形尺寸图
2.2.3	Conditions for reflow 回流焊焊接	Soldering area: t/2 of P.W.B. thickness (P.W.B:T=1.6) 焊接面积：印刷基板的1/2 厚度处 (P.W.B:T=1.6) Soldering temperature : 250± 5℃ 焊接温度： 250± 5℃ soldering time : 5 ±1s 焊接时间： 5 ±1 秒 【适用于贴片式产品】	No damage (electrical andmechanical) 无异常。 (电气、机械特性)
2.2.4	Wave-soldering 波峰焊焊接	Terminals shall be dipped in the solder bath at 235±5℃ for 5±1s Max (seconds without additional force for terminals) 端子焊接部分浸入焊炉，锡炉温度 235±5℃，焊接时间最多 5±1 秒。（焊接时不可于端子施加外力）。 插件物料手工焊接时需保证烙铁设置温度在 350℃时，焊接时间 3 秒内，烙铁头接触引脚与元件本体距离要求为 2~4MM 之间； 【适用于插件式产品】	No damage (electrical andmechanical) 无异常。 (电气、机械特性)
2.2.5	Solderbility 可焊性	After sprated flux 涂上助焊剂后 temperature :235± 5℃ 温度： 235± 5℃ soldering time :2±0.5 sec 焊接时间： 2±0.5 秒	90% or more of surface area of the portion immersed in solder shall be covered by new solder 90% 或更多的浸焊面积能被焊锡覆盖。
2.2.6	Shock 耐冲击性	Measure after test at a condition below 在下列条件下进行测试后的量度 Peak acceleration----80G 冲击加速度-80G Test time-6direction ,each 3 times total 18times 测试次数-6 个方向，各3 次共计18 次。 	No.2.1 and 2.2.1 to 2.2.2 shall be satisfied 第2.1 及2.2.1—2.2.2 都应符合要求

 KOREAN HROPARTS ELECTRONICS CO.,LTD		文件编号 FILE NO.	HR-SPEC-001	页码 PAGE	3/5
		发布日期 DATE OF ISSUE	2016 年 10 月 09 日		
PRODUCT SPECIFICATION 产品承认书		文件版本 EDITION	第 A 版 第 3 次修订		
Title 名称	轻触开关 TACT SWITCH	产品料号 PART NO.	轻触开关系列 I		

2.3 Durability characteristics 耐久性

2.3.1	Endurance (switching action) 耐久特性 (开关寿命)	(1) D.C.12V 50mA resistance load D.C 12V 50mA 电阻负荷 (2) Operation speed : 30 times /M 动作速度: 30次/分 (3) Push force : Maximum value of operation force 按力: 动作力规格值的上限 (4) Operation number: 100,000 times 动作次数: 10 万	Contact resistance 200mΩ max 接触电阻 200mΩ 以下 Bouncing: 10 ms max 触点抖动: 10 秒以下 Variation rate of operation force shall be within ±30%to the value before testing 动作力的变化范围在初始值的±30%以内 No. 2. 1. 2 and 2. 2. 2 shall Be satisfied 满足 2. 1. 2 和 2. 2. 2 项
-------	---	--	--

2.4 Climatic characteristics 耐候性能

No.	Item 项目	Test condition 试验条件	Performance 规格
2.4.1	Cold test 耐寒性	(1) Temperature : - 40±2℃ 温度: - 40±2℃ (2) Duration of test: 96h 持续时间: 96 小时 (3) Take off a drop water 去掉水珠 (4) Standard conditions after test : 1h 试验后的放置条件: 1 小时	Contact resistance 200mΩ max No. 2.1.2 to 2.1.4 and No. 2.2.1 to 2.2.2 shall Be satisfied 接触电阻 200mΩ以下 满足2.1.2 到2.1.4 项、2.2.1到2.2.2 项.
2.4.2	Heat test 耐热性	(1) Temperature : 85±2℃ 温度: 85±2℃ (2) Duration of test: 96h 持续时间: 96 小时 (3) Standard conditions after test : 1h 试验后的放置条件: 1 小时	Contact resistance 200mΩmax No. 2.1.2 to 2.1.4 and No. 2.2.1 to 2.2.2 shall Be satisfied 接触电阻 200mΩ以下 满足2.1.2 到2.1.4 项2.2.1到2.2.2 项.

 KOREAN HROPARTS ELECTRONICS CO.,LTD		文件编号 FILE NO.	HR-SPEC-001	页码 PAGE	4/5
		发布日期 DATE OF ISSUE	2016 年 10 月 09 日		
PRODUCT SPECIFICATION 产品承认书		文件版本 EDITION	第 A 版 第 3 次修订		
Title 名称	轻触开关 TACT SWITCH	产品料号 PART NO.	轻触开关系列 I		

NO.	Item 项目	Test condition 试验条件	Performance 规格													
2.4.3	Temperature cycle 温度循环	(1) Test cycles :20 cycles 试验周期: 20 个周期 (2) Standard condition after test :1h 试验后的放置条件: 1 小时 <table border="1" data-bbox="402 667 1007 920"> <thead> <tr> <th></th> <th>temperature 温度</th> <th>duration of test 持续时间</th> </tr> </thead> <tbody> <tr> <td>1 cycle 一次</td> <td>20±5℃</td> <td>1h</td> </tr> <tr> <td rowspan="3">循环</td> <td>-40±2℃</td> <td>1h</td> </tr> <tr> <td>20±5℃</td> <td>1h</td> </tr> <tr> <td>85±5℃</td> <td>1h</td> </tr> </tbody> </table>		temperature 温度	duration of test 持续时间	1 cycle 一次	20±5℃	1h	循环	-40±2℃	1h	20±5℃	1h	85±5℃	1h	No damage Electricalandmechanical 无异常 电气、机械性能
	temperature 温度	duration of test 持续时间														
1 cycle 一次	20±5℃	1h														
循环	-40±2℃	1h														
	20±5℃	1h														
	85±5℃	1h														
2.4.4	Humidity test 耐湿性	(1) Temperature : 60±2℃ 温度: 60±2℃ (2) relative humidity: 90~95% 相对湿度:90~95% (3) Duration of test: 96h 持续时间: 96 小时 (3) Take off a drop water 去掉水珠 (4) Standard conditions after test : 1h 试验后的放置条件: 1 小时	Contact resistance 200mΩ max No. 2.1.2 to 2.1.4 and No. 2.2.1 to 2.2.2 shall Be satisfied 接触电阻 200mΩ以下 满足2.1.2 到2.1.4 项、2.2.1 到2.2.2 项.													
2.4.5	Salt mist 盐雾实验	The switch shall be subjugted to a fime mist of salt solution at a temperature of 35±2℃ for 24H continuously (salt solution concentration 5±1% by weight) 温度: 35±2℃ 浓度: 5±1% 时间: 24H	Without excessive rust Contact resistance 200mΩ max													

 KOREAN HROPARTS ELECTRONICS CO.,LTD		文件编号 FILE NO.	HR-SPEC-001	页码 PAGE	5/5
		发布日期 DATE OF ISSUE	2016年10月09日		
PRODUCT SPECIFICATION 产品承认书		文件版本 EDITION	第 A 版 第 3 次修订		
Title 名称	轻触开关 TACT SWITCH	产品料号 PART NO.	轻触开关系列 I		

3. Precaution 注意事项 3.1 Soldering condition 浸焊条件

ITEM项目	CONDITION条件
Preheat temperature 预热温度	110°C max (Embilomental temperature of soldering surface of P. W. E) 110°C 以下(印刷基板焊锡面周围的温度)
Preheat time 预热时间	60 sec, max 60 秒以内
Area of flux 助焊剂的面积	1/2 max of P. W. B. thickness 印刷基板厚度的 1/2 以内
Temperature of solder 焊锡温度	250°C max 250°C 以下
Time of immersion 浸焊时间	Within 5 sec 5 秒以内
Soldering number 浸焊次数	Within 2 times (But should bring down heat of the first soldering) 2 次以内 (但应把第一次焊锡的温度降下来)
Printed wiring board 印刷基板	Single sided copper-clad laminates 单面铜箔

(1) After switches were soldered, please be careful not to clean switches with solvent
开关浸焊后,注意不要用溶剂清洗.

(2) In the case of using soldering iron, soldering conditions shall be 350°C max and 3 sec. max
在使用烙铁的情况下,焊锡温度应在350°C 以下、3 秒以内.

(3) Right after switches were soldered; please be careful not to load on the knobs of switches.
浸焊后,注意不要在顶部施加负荷.

3.2 Design instructions(设计中应注意的事项)

(1) Follow recommended P. W. B. piercing plan in outside drawing page. 印刷基板的安装孔尺寸参见产品图.

(2) Design key top as fig. Design inclination of key top 4 deg. max as fig. (Recommended operating condition.)
击键部设计如图,击键部倾斜度如图在4 度以内. (参见操作条件).

3.3 Note(注意点)

(1) Please be cautious not to give excessive static load or shock to switches.
注意不要施加超负荷的压力或晃动开关.

(2) Please be careful not to pile up P. W. B. after switches were soldered.
开关焊接以后,印刷基板注意不要叠放.

(3) Preservation under high temperature and high humidity or corrosive gas should be avoided especially. When you need to preserve for a long period, do not open the carton.
保管时尤其应注意避开高湿高温和有腐蚀性气体的环境.如需长时间保存,请不要打开包装袋.

制表: 胡梅

审核: 徐其峰

核准: 卢建昆