



SGM2554

Power Distribution Switch

GENERAL DESCRIPTION

The SGM2554 is an integrated 100mΩ (TYP) power switch for self-powered and bus-powered Universal Series Bus (USB) applications. A built-in charge pump is used to drive the N-Channel MOSFET that is free of parasitic body diode to eliminate any reversed current flow across the switch when it is powered off. Low quiescent supply current and small package are particularly suitable in battery-powered portable equipment.

Several protection functions include soft-start to limit inrush current during plug-in, current limiting at 1.85A to meet USB power requirement, and thermal shutdown to protect damage under over current conditions.

The SGM2554 is available in a Green SOT-23-5 package and is rated over the -40°C to +85°C temperature range.

FEATURES

- 100mΩ (TYP) High-side N-Channel MOSFET
- Guaranteed 1.2A Continuous Current
- 1.85A Current Limit
- Soft-Start Function
- Thermal Shutdown Protection
- Low 21μA Supply Current
- Less than 1μA in Shutdown Mode
- Under-Voltage Lockout Protection for V_{IN}
- Input Voltage Range: 2.2V to 5.5V
- No Reversed Leakage Current
- Available in Green SOT-23-5 Package

APPLICATIONS

Motherboard USB Power Switch
 USB Device Power Switch
 Hot-Plug Power Supplies
 Load Switch

TYPICAL APPLICATION

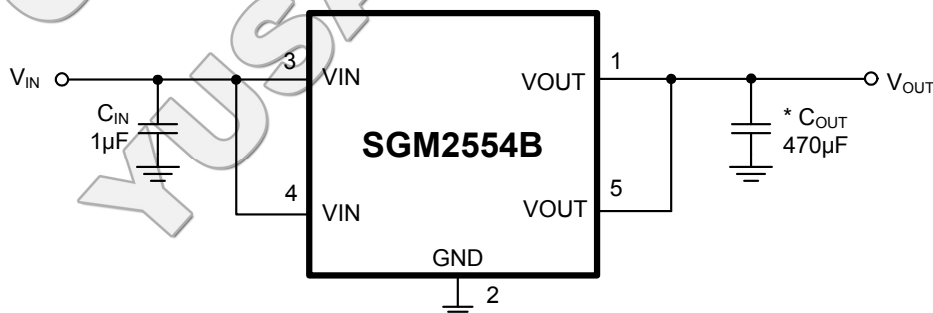

* 470μF, Low ESR Electrolytic

PACKAGE/ORDERING INFORMATION

MODEL	PIN-PACKAGE	SPECIFIED TEMPERATURE RANGE	ORDERING NUMBER	PACKAGE MARKING	PACKAGE OPTION
SGM2554A	SOT-23-5	-40°C to +85°C	SGM2554AYN5G/TR	SI4XX	Tape and Reel, 3000
SGM2554B	SOT-23-5	-40°C to +85°C	SGM2554BYN5G/TR	SI5XX	Tape and Reel, 3000

NOTE: XX = Date Code.

MARKING INFORMATION

SYX X X

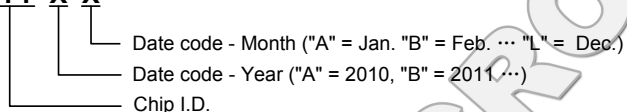

For example: SI4CA (2012, January)

ABSOLUTE MAXIMUM RATINGS

Input Supply Voltage.....	6V
EN Pin.....	-0.3V to 6V
Operating Temperature Range.....	-40°C to +85°C
Storage Temperature Range.....	-65°C to +150°C
Power Dissipation, P _D @ T _A = 25°C	
SOT-23-5.....	0.25W
Package Thermal Resistance	
SOT-23-5, θ _{JA}	250°C/W
Lead Temperature (Soldering, 10s).....	260°C
ESD Susceptibility	
HBM.....	V
MM.....	V

CAUTION

This integrated circuit can be damaged by ESD if you don't pay attention to ESD protection. SGMICRO recommends that all integrated circuits be handled with appropriate precautions. Failure to observe proper handling and installation procedures can cause damage. ESD damage can range from subtle performance degradation to complete device failure. Precision integrated circuits may be more susceptible to damage because very small parametric changes could cause the device not to meet its published specifications.

SGMICRO reserves the right to make any change in circuit design, specification or other related things if necessary without notice at any time. Please contact SGMICRO sales office to get the latest datasheet.

NOTE:

Stresses beyond those listed under "Absolute Maximum Ratings" may cause permanent damage to the device. These are stress ratings only, and functional operation of the device at these or any other conditions beyond those indicated in the operational sections of the specifications is not implied. Exposure to absolute maximum rating conditions for extended periods may affect device reliability.

PIN CONFIGURATIONS (TOP VIEW)

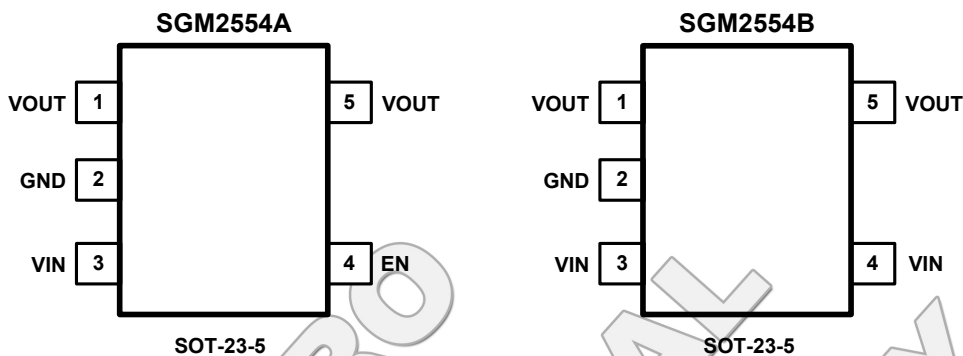

PIN DESCRIPTION

PIN		NAME	FUNCTION
SGM2554A	SGM2554B		
1, 5	1, 5	VOUT	Output Voltage.
2	2	GND	Ground.
3	3, 4	VIN	Power Input Voltage.
4	—	EN	Chip Enable. When EN = "High", chip is enabled.

FUNCTION BLOCK DIAGRAM

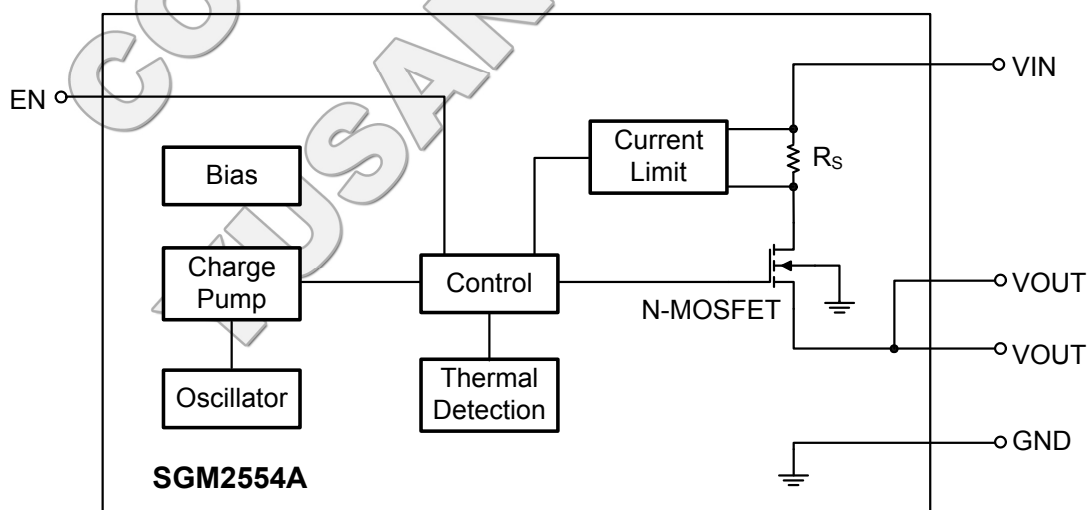

ELECTRICAL CHARACTERISTICS(V_{IN} = 5V, C_{IN} = C_{OUT} = 1μF, T_A = 25°C, unless otherwise noted.)

PARAMETER	SYMBOL	CONDITIONS	MIN	TYP	MAX	UNITS
Input Voltage Range	V _{IN}		2.2		5.5	V
R _{DS(ON)} of N-MOSFET	SGM2554A	I _L = 1A		100		mΩ
	SGM2554B	I _L = 1A		100		
Quiescent Supply Current	I _Q	V _{IN} = 3V		18		μA
		V _{IN} = 5V		21		
Shutdown Supply Current (SGM2554A)	I _{SD}	V _{EN} = 0V		0.1		μA
Output Turn-On Rising Time	T _R	R _L = 30Ω, 90% Settling		1.1		ms
Current Limit Threshold	I _{LIMIT}	R _L = 2Ω		1.85		A
Short-Circuit Fold Back Current	I _{SHORT}	V _{OUT} = 0V, V _{IN} = 3V		1.3		A
EN Input High Threshold (SGM2554A)	V _{EN}		1.5			V
EN Input Low Threshold (SGM2554A)					0.5	
Output Leakage Current (SGM2554A)	I _{LEAKAGE}	V _{EN} = 0V, V _{OUT} = 0V		0.2		μA
Under-Voltage Lockout Threshold	UVLO			1.65		V
Under-Voltage Lockout Threshold Hysteresis				50		mV
Thermal Shutdown Temperature				125		°C
Thermal Shutdown Temperature Hysteresis				20		°C

TYPICAL PERFORMANCE CHARACTERISTICS

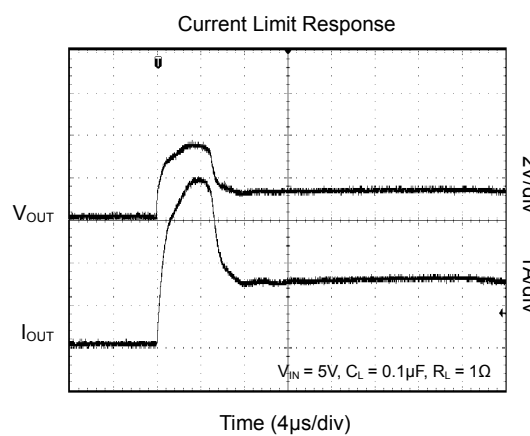
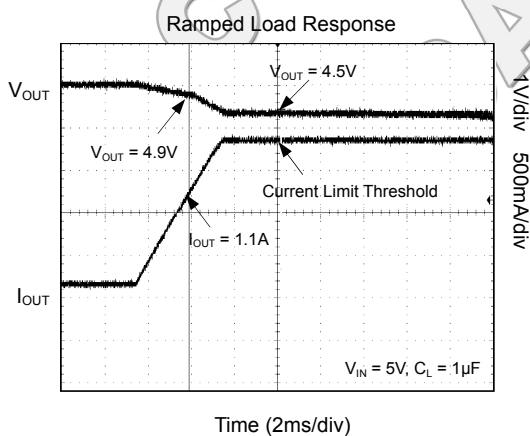
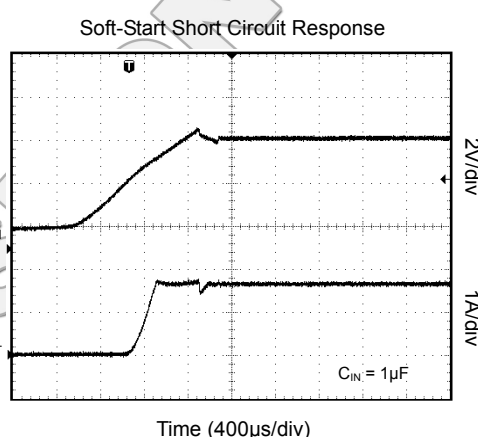
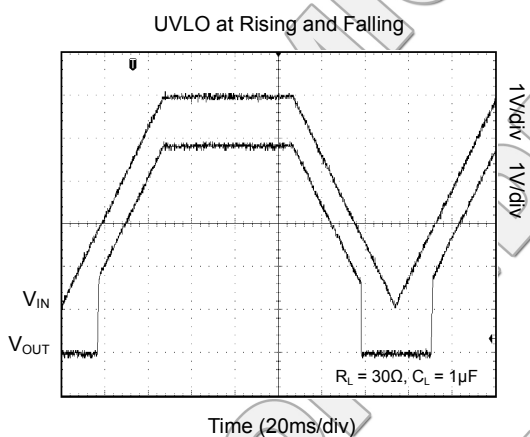
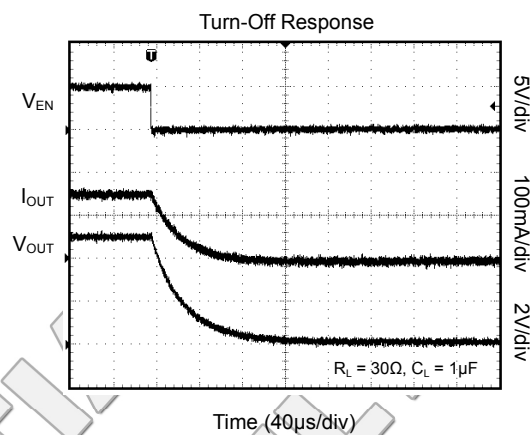
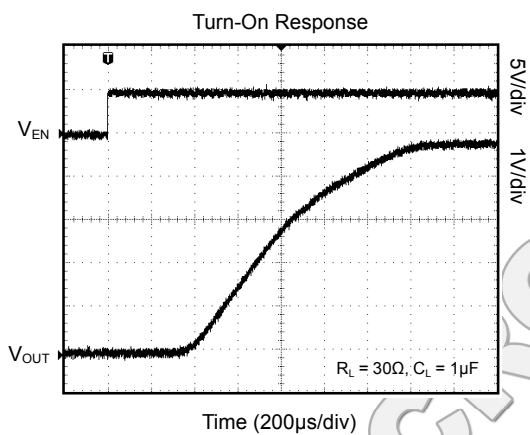

TYPICAL PERFORMANCE CHARACTERISTICS

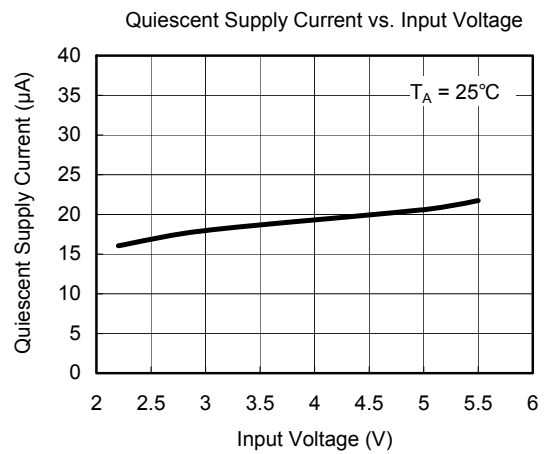
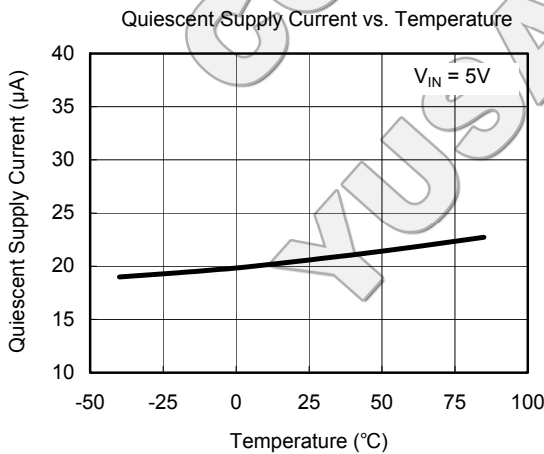
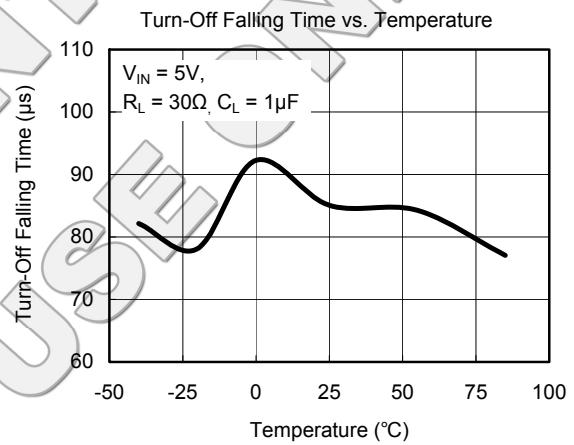
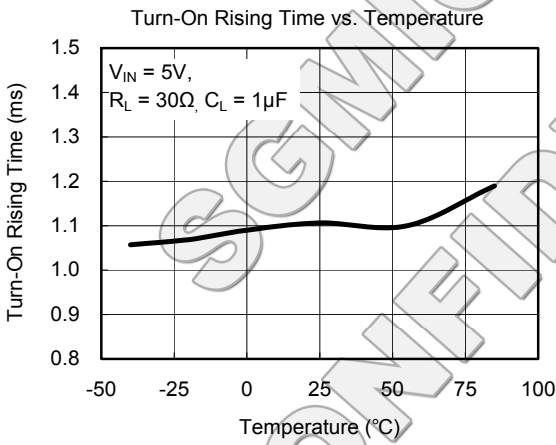
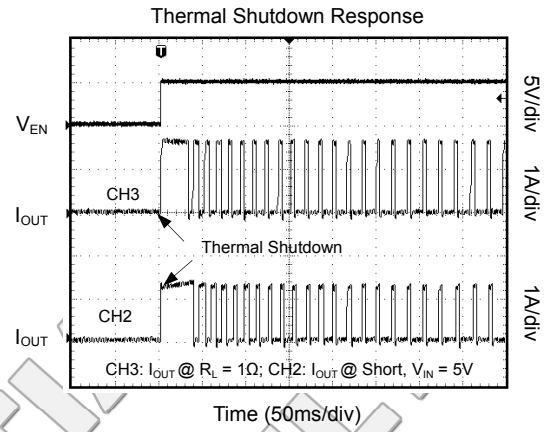
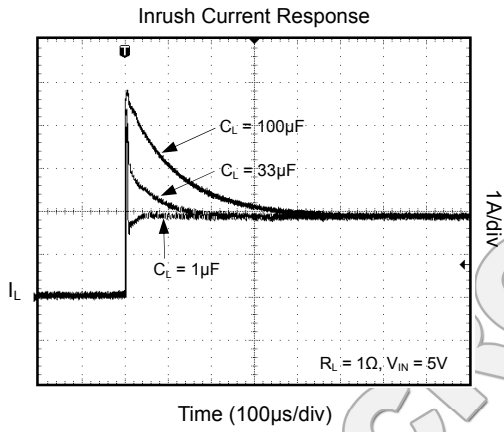

TYPICAL PERFORMANCE CHARACTERISTICS

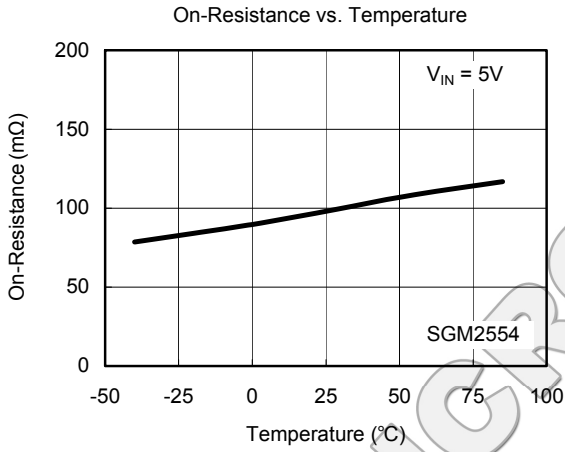

SGMICRO
CONFIDENTIAL
YUSAN USE ONLY

TEST CIRCUITS

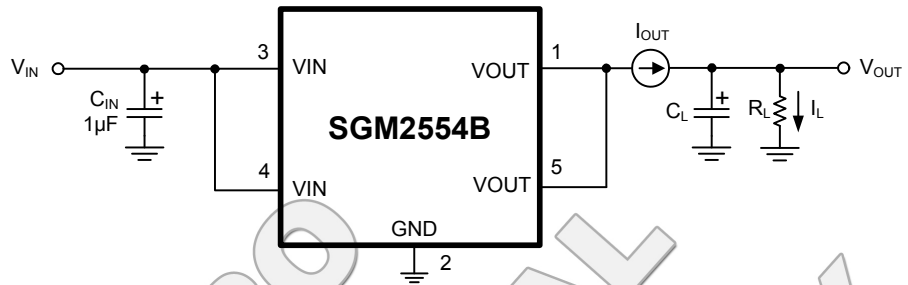

Test Circuit 1

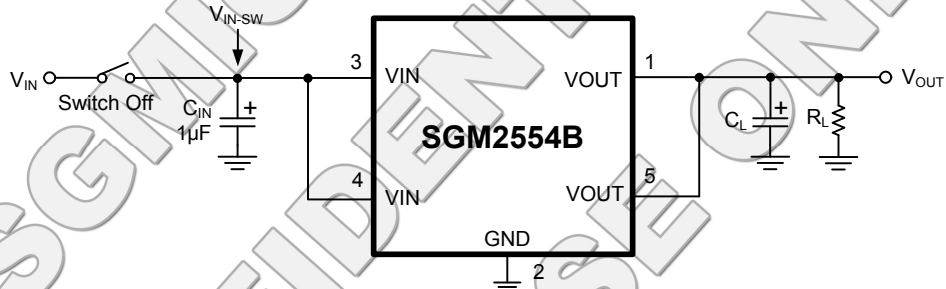

Test Circuit 2

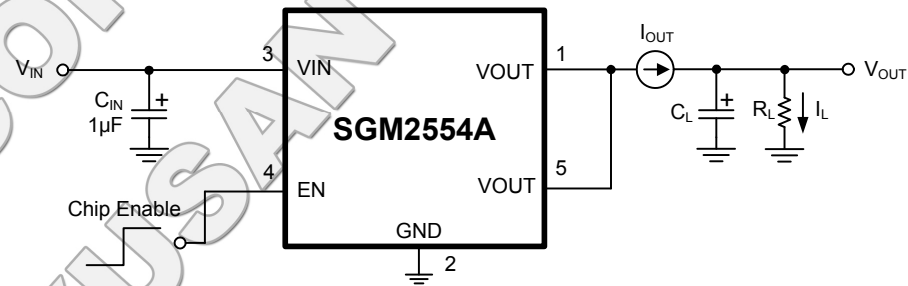

Test Circuit 3

NOTE: Test Circuit 2 is performed by charging an external tank of bulk capacitor to the input then applying this voltage to the input of the unit.

APPLICATION INFORMATION

The SGM2554 is a high-side single N-Channel MOSFET switch and SGM2554A has active-high enable input.

Input and Output

VIN (input) is the power supply connection to the circuitry and the drain of the output MOSFET. VOUT (output) is the source of the output MOSFET. In a typical circuit, current flows through the switch from VIN to VOUT toward the load. Both VOUT pins must be short on the board and connected to the load and so do both VIN pins but connected to the power source.

Thermal Shutdown

Thermal shutdown shuts off the output MOSFET if the die temperature exceeds 125°C until the die temperature drops to 105°C.

Soft-Start

In order to eliminate the upstream voltage droop caused by the large inrush current during hot-plug events, the “soft-start” feature effectively isolates power supplies from such highly capacitive loads.

Under-Voltage Lockout (UVLO)

UVLO prevents the MOSFET switch from turning on until input voltage exceeds 1.65V (typical). If input voltage drops below 1.6V (typical), UVLO shuts off the MOSFET switch.

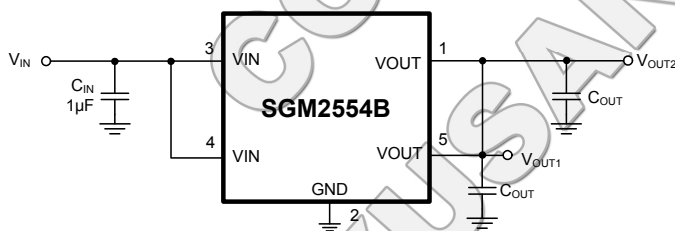

C_{IN} = 1µF, C_{OUT} = 470µF (Low ESR) on M/B
 C_{IN} = 1µF, C_{OUT} = 330µF (Low ESR) on Notebook
 C_{IN} = 10µF, C_{OUT} = 1µF on USB Device

Figure 1. High-side Power Switch

Current Limiting and Short Protection

The current limit circuit is designed to protect the system supply. The current limit threshold is set internally to allow a minimum of 1.3A through the MOSFET but limits the output current to approximately 1.85A (typical). When the output is shorted to ground, it will be limited to a constant current of 1.2A until thermal shutdown or short condition is removed.

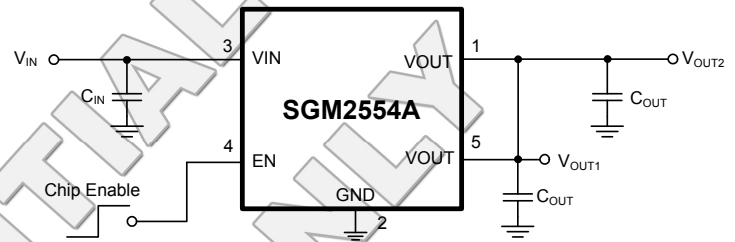

Figure 2. High-side Power Switch with Chip Enable Control

Reverse Voltage Protection

The reverse voltage protection feature turns off the N-Channel MOSFET switch whenever the output voltage exceeds the input voltage by 70mV (typical). The SGM2554 keeps the N-Channel MOSFET turned off until the output voltage is lower than the input voltage by 30mV (typical) or the chip enable is toggled.

APPLICATION INFORMATION

Filtering

To limit the input voltage drop during hot-plug events, connect a 1 μ F ceramic capacitor from VIN to GND. However, higher capacitor values will further reduce the voltage drop at the input.

Connect a sufficiently large capacitor from VOUT to GND. This capacitor helps to prevent inductive parasitics from pulling VOUT negative during turn-off or EMI damage to other components during the hot-detachment. It is also necessary for meeting the USB specification during hot plug-in operation. If SGM2554 is implanted in device end application, minimum 1 μ F capacitor from VOUT to GND is recommended and higher capacitor values are also preferred.

In choosing these capacitors, special attention must be paid to the Effective Series Resistance (ESR) of the capacitors, to minimize the IR drop across the capacitor ESR. A lower ESR on this capacitor can get a lower IR drop during the operation.

Ferrite beads in series with all power and ground lines are recommended to eliminate or significantly reduce EMI. In selecting a ferrite bead, the DC resistance of the wire used must be kept to a minimum to reduce the voltage drop.

Layout and Thermal Dissipation

- Place the switch as close to the USB connector as possible. Keep all traces as short as possible to reduce the effect of undesirable parasitic inductance.
- Place the output capacitor and ferrite beads as close as possible to the USB connector.
- If ferrite beads are used, use wires with minimum resistance and large solder pads to minimize connection resistance.
- If the package is with dual VOUT or VIN pins, short both the same function pins as Figure 1 or Figure 2 to reduce the internal turn-on resistance. If the output power will be delivered to two individual ports, it is specially necessary to short both VOUT pins at the switch output side in order to protect the switch when each port is plug-in separately.
- Under normal operating conditions, the package can dissipate the channel heat away. Wide power-bus planes connected to VIN and VOUT and a ground plane in contact with the device will help dissipate additional heat.

PACKAGE OUTLINE DIMENSIONS

SOT-23-5

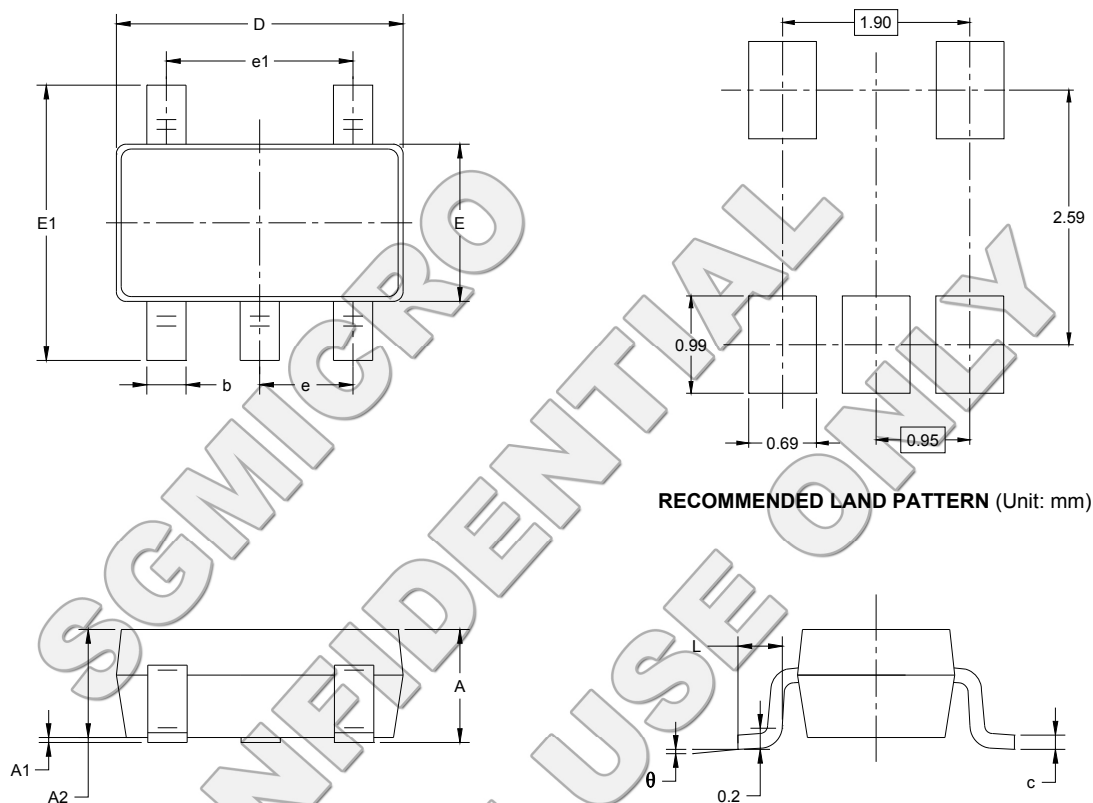

RECOMMENDED LAND PATTERN (Unit: mm)

Symbol	Dimensions In Millimeters		Dimensions In Inches	
	MIN	MAX	MIN	MAX
A	1.050	1.250	0.041	0.049
A1	0.000	0.100	0.000	0.004
A2	1.050	1.150	0.041	0.045
b	0.300	0.500	0.012	0.020
c	0.100	0.200	0.004	0.008
D	2.820	3.020	0.111	0.119
E	1.500	1.700	0.059	0.067
E1	2.650	2.950	0.104	0.116
e	0.950 BSC		0.037 BSC	
e1	1.900 BSC		0.075 BSC	
L	0.300	0.600	0.012	0.024
θ	0°	8°	0°	8°

TAPE AND REEL INFORMATION

REEL DIMENSIONS

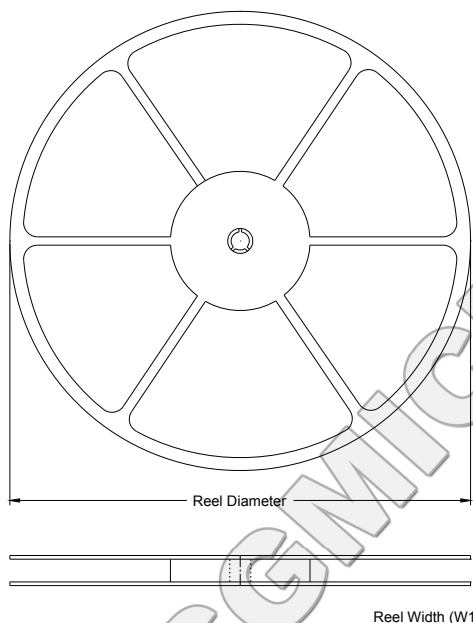

TAPE DIMENSIONS

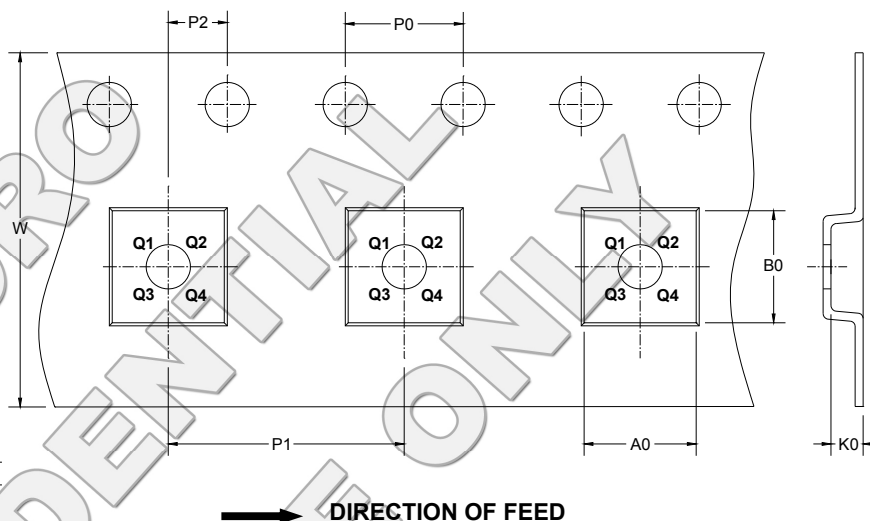

NOTE: The picture is only for reference. Please make the object as the standard.

KEY PARAMETER LIST OF TAPE AND REEL

Package Type	Reel Diameter	Reel Width W1 (mm)	A0 (mm)	B0 (mm)	K0 (mm)	P0 (mm)	P1 (mm)	P2 (mm)	W (mm)	Pin1 Quadrant
SOT-23-5	7"	9.5	3.17	3.23	1.37	4.0	4.0	2.0	8.0	Q3

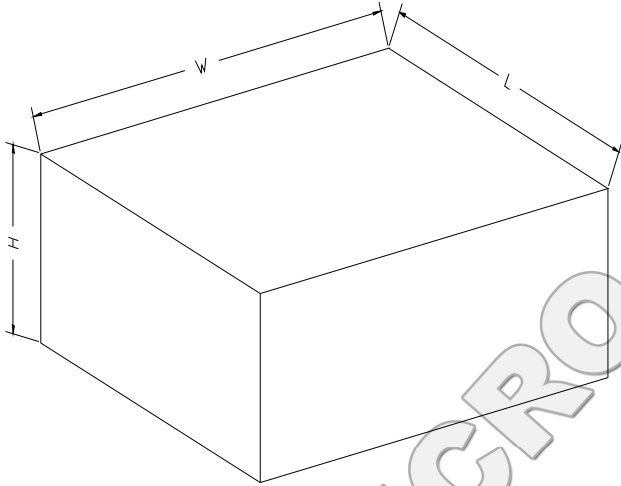
CARTON BOX DIMENSIONS

NOTE: The picture is only for reference. Please make the object as the standard.

KEY PARAMETER LIST OF CARTON BOX

Reel Type	Length (mm)	Width (mm)	Height (mm)	Pizza/Carton
7" (Option)	368	227	224	8
7"	442	410	224	18