

TPS1101, TPS1101Y SINGLE P-CHANNEL ENHANCEMENT-MODE MOSFETS

SLVS079C – DECEMBER 1993 – REVISED AUGUST 1995

- Low $r_{DS(on)}$. . . 0.09 Ω Typ at $V_{GS} = -10$ V
- 3 V Compatible
- Requires No External V_{CC}
- TTL and CMOS Compatible Inputs
- $V_{GS(th)} = -1.5$ V Max
- Available in Ultrathin TSSOP Package (PW)
- ESD Protection Up to 2 kV per MIL-STD-883C, Method 3015

description

The TPS1101 is a single, low- $r_{DS(on)}$, P-channel, enhancement-mode MOSFET. The device has been optimized for 3-V or 5-V power distribution in battery-powered systems by means of the Texas Instruments LinBiCMOS™ process. With a maximum $V_{GS(th)}$ of -1.5 V and an I_{DSS} of only 0.5 μ A, the TPS1101 is the ideal high-side switch for low-voltage, portable battery-management systems where maximizing battery life is a primary concern. The low $r_{DS(on)}$ and excellent ac characteristics (rise time 5.5 ns typical) of the TPS1101 make it the logical choice for low-voltage switching applications such as power switches for pulse-width-modulated (PWM) controllers or motor/bridge drivers.

The ultrathin thin shrink small-outline package or TSSOP (PW) version fits in height-restricted places where other P-channel MOSFETs cannot. The size advantage is especially important where board height restrictions do not allow for a small-outline integrated circuit (SOIC) package. Such applications include notebook computers, personal digital assistants (PDAs), cellular telephones, and PCMCIA cards. For existing designs, the D-packaged version has a pinout common with other P-channel MOSFETs in SOIC packages.

D PACKAGE
(TOP VIEW)

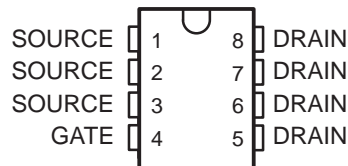

D PACKAGE

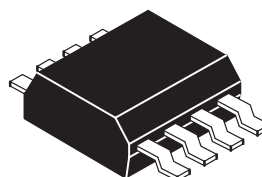

PW PACKAGE

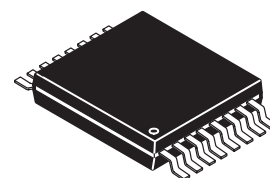

PW PACKAGE
(TOP VIEW)

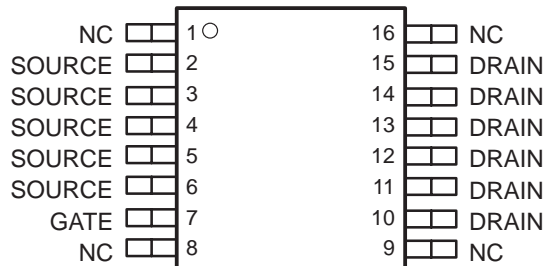

NC – No internal connection

AVAILABLE OPTIONS

T _J	PACKAGED DEVICES†		CHIP FORM (Y)
	SMALL OUTLINE (D)	TSSOP (PW)	
-40°C to 150°C	TPS1101D	TPS1101PWLE	TPS1101Y

† The D package is available taped and reeled. Add an R suffix to device type (e.g., TPS1101DR). The PW package is only available left-end taped and reeled (indicated by the LE suffix on the device type; e.g., TPS1101PWLE). The chip form is tested at 25°C.



Please be aware that an important notice concerning availability, standard warranty, and use in critical applications of Texas Instruments semiconductor products and disclaimers thereto appears at the end of this data sheet.

LinBiCMOS is a trademark of Texas Instruments Incorporated.

PRODUCTION DATA information is current as of publication date. Products conform to specifications per the terms of Texas Instruments standard warranty. Production processing does not necessarily include testing of all parameters.

 **TEXAS
INSTRUMENTS**

POST OFFICE BOX 655303 • DALLAS, TEXAS 75265

Copyright © 1995, Texas Instruments Incorporated

TPS1101, TPS1101Y SINGLE P-CHANNEL ENHANCEMENT-MODE MOSFETS

SLVS079C – DECEMBER 1993 – REVISED AUGUST 1995

schematic

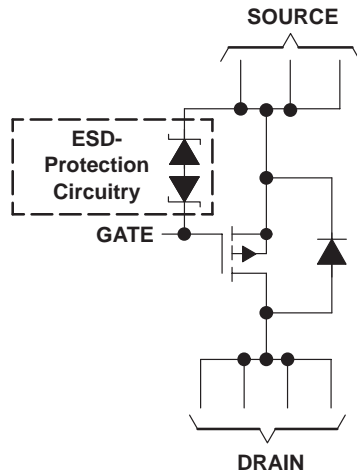

NOTE A: For all applications, all source terminals should be connected and all drain terminals should be connected.

TPS1101Y chip information

This chip, when properly assembled, displays characteristics similar to the TPS1101. Thermal compression or ultrasonic bonding may be used on the doped aluminum bonding pads. The chips may be mounted with conductive epoxy or a gold-silicon preform.

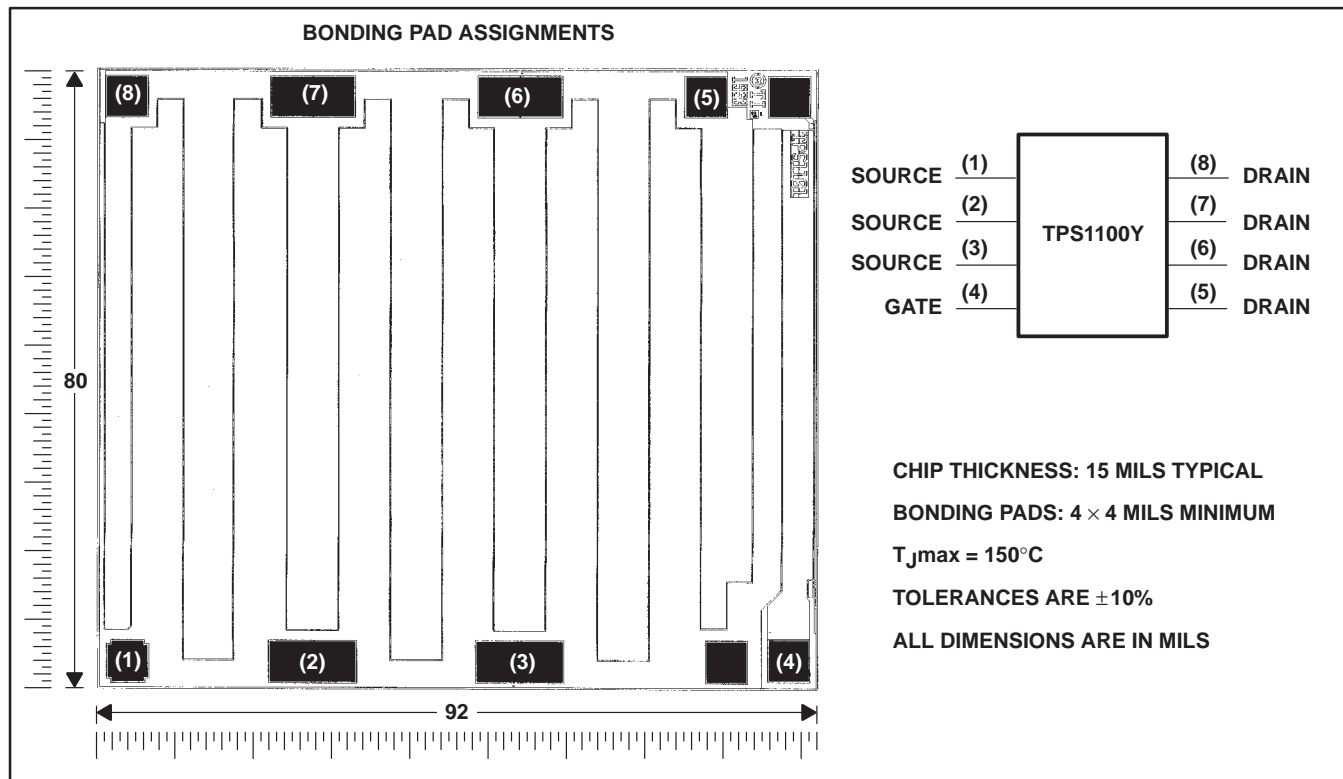

TPS1101, TPS1101Y

SINGLE P-CHANNEL ENHANCEMENT-MODE MOSFETS

SLVS079C – DECEMBER 1993 – REVISED AUGUST 1995

absolute maximum ratings over operating free-air temperature (unless otherwise noted)[†]

				UNIT	
Drain-to-source voltage, V_{DS}				- 15	V
Gate-to-source voltage, V_{GS}				2 or - 15	V
Continuous drain current ($T_J = 150^\circ\text{C}$), $I_{D\ddagger}$	$V_{GS} = -2.7\text{ V}$	D package	$T_A = 25^\circ\text{C}$	± 0.62	A
			$T_A = 125^\circ\text{C}$	± 0.39	
		PW package	$T_A = 25^\circ\text{C}$	± 0.61	
			$T_A = 125^\circ\text{C}$	± 0.38	
	$V_{GS} = -3\text{ V}$	D package	$T_A = 25^\circ\text{C}$	± 0.88	
			$T_A = 125^\circ\text{C}$	± 0.47	
		PW package	$T_A = 25^\circ\text{C}$	± 0.86	
			$T_A = 125^\circ\text{C}$	± 0.45	
	$V_{GS} = -4.5\text{ V}$	D package	$T_A = 25^\circ\text{C}$	± 1.52	
			$T_A = 125^\circ\text{C}$	± 0.71	
		PW package	$T_A = 25^\circ\text{C}$	± 1.44	
			$T_A = 125^\circ\text{C}$	± 0.67	
$V_{GS} = -10\text{ V}$	D package	$T_A = 25^\circ\text{C}$	± 2.30		
		$T_A = 125^\circ\text{C}$	± 1.04		
	PW package	$T_A = 25^\circ\text{C}$	± 2.18		
		$T_A = 125^\circ\text{C}$	± 0.98		
Pulsed drain current, $I_{D\ddagger}$			$T_A = 25^\circ\text{C}$	± 10	A
Continuous source current (diode conduction), I_S			$T_A = 25^\circ\text{C}$	- 1.1	A
Storage temperature range, T_{stg}				-55 to 150	$^\circ\text{C}$
Operating junction temperature range, T_J				-40 to 150	$^\circ\text{C}$
Operating free-air temperature range, T_A				-40 to 125	$^\circ\text{C}$
Lead temperature 1,6 mm (1/16 inch) from case for 10 seconds				260	$^\circ\text{C}$

[†] Stresses beyond those listed under “absolute maximum ratings” may cause permanent damage to the device. These are stress ratings only, and functional operation of the device at these or any other conditions beyond those indicated under “recommended operating conditions” is not implied. Exposure to absolute-maximum-rated conditions for extended periods may affect device reliability.

[‡] Maximum values are calculated using a derating factor based on $R_{\theta JA} = 158^\circ\text{C}/\text{W}$ for the D package and $R_{\theta JA} = 176^\circ\text{C}/\text{W}$ for the PW package. These devices are mounted on an FR4 board with no special thermal considerations.

DISSIPATION RATING TABLE

PACKAGE	$T_A \leq 25^\circ\text{C}$ POWER RATING	DERATING FACTOR [‡] ABOVE $T_A = 25^\circ\text{C}$	$T_A = 70^\circ\text{C}$ POWER RATING	$T_A = 85^\circ\text{C}$ POWER RATING	$T_A = 125^\circ\text{C}$ POWER RATING
D	791 mW	6.33 mW/ $^\circ\text{C}$	506 mW	411 mW	158 mW
PW	710 mW	5.68 mW/ $^\circ\text{C}$	454 mW	369 mW	142 mW

[‡] Maximum values are calculated using a derating factor based on $R_{\theta JA} = 158^\circ\text{C}/\text{W}$ for the D package and $R_{\theta JA} = 176^\circ\text{C}/\text{W}$ for the PW package. These devices are mounted on an FR4 board with no special thermal considerations.

TPS1101, TPS1101Y SINGLE P-CHANNEL ENHANCEMENT-MODE MOSFETS

SLVS079C – DECEMBER 1993 – REVISED AUGUST 1995

electrical characteristics at $T_J = 25^\circ\text{C}$ (unless otherwise noted)

static

PARAMETER	TEST CONDITIONS	TPS1101			TPS1101Y			UNIT
		MIN	TYP	MAX	MIN	TYP	MAX	
$V_{GS(th)}$ Gate-to-source threshold voltage	$V_{DS} = V_{GS}$, $I_D = -250 \mu\text{A}$	-1	-1.25	-1.5		-1.25		V
V_{SD} Source-to-drain voltage (diode-forward voltage) [†]	$I_S = -1 \text{ A}$, $V_{GS} = 0 \text{ V}$		-1.04			-1.04		V
I_{GSS} Reverse gate current, drain short circuited to source	$V_{DS} = 0 \text{ V}$, $V_{GS} = -12 \text{ V}$			± 100				nA
I_{DSS} Zero-gate-voltage drain current	$V_{DS} = -12 \text{ V}$, $V_{GS} = 0 \text{ V}$	$T_J = 25^\circ\text{C}$		-0.5				μA
		$T_J = 125^\circ\text{C}$		-10				
$r_{DS(on)}$ Static drain-to-source on-state resistance [†]	$V_{GS} = -10 \text{ V}$	$I_D = -2.5 \text{ A}$		90		90		m Ω
	$V_{GS} = -4.5 \text{ V}$	$I_D = -1.5 \text{ A}$		134	190	134		
	$V_{GS} = -3 \text{ V}$	$I_D = -0.5 \text{ A}$		198	310	198		
	$V_{GS} = -2.7 \text{ V}$			232	400	232		
g_{fs} Forward transconductance [†]	$V_{DS} = -10 \text{ V}$, $I_D = -2 \text{ A}$		4.3			4.3		S

[†] Pulse test: pulse duration $\leq 300 \mu\text{s}$, duty cycle $\leq 2\%$

dynamic

PARAMETER	TEST CONDITIONS	TPS1101, TPS1101Y			UNIT
		MIN	TYP	MAX	
Q_g Total gate charge	$V_{DS} = -10 \text{ V}$, $V_{GS} = -10 \text{ V}$, $I_D = -1 \text{ A}$		11.25		nC
Q_{gs} Gate-to-source charge			1.5		
Q_{gd} Gate-to-drain charge			2.6		
$t_{d(on)}$ Turn-on delay time	$V_{DD} = -10 \text{ V}$, $R_L = 10 \Omega$, $I_D = -1 \text{ A}$, $R_G = 6 \Omega$, See Figures 1 and 2		6.5		ns
$t_{d(off)}$ Turn-off delay time			19		ns
t_r Rise time			5.5		ns
t_f Fall time			13		
$t_{rr(SD)}$ Source-to-drain reverse recovery time		$I_F = 5.3 \text{ A}$, $di/dt = 100 \text{ A}/\mu\text{s}$		16	

PARAMETER MEASUREMENT INFORMATION

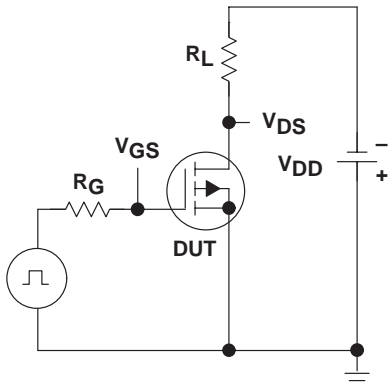

Figure 1. Switching-Time Test Circuit

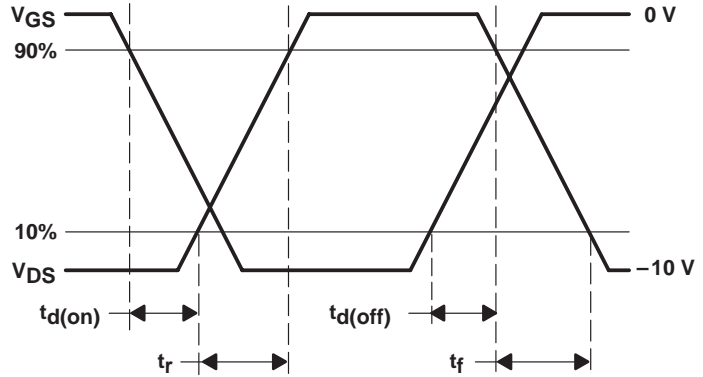

Figure 2. Switching-Time Waveforms

TYPICAL CHARACTERISTICS

Table of Graphs

		FIGURE
Drain current	vs Drain-to-source voltage	3
Drain current	vs Gate-to-source voltage	4
Static drain-to-source on-state resistance	vs Drain current	5
Capacitance	vs Drain-to-source voltage	6
Static drain-to-source on-state resistance (normalized)	vs Junction temperature	7
Source-to-drain diode current	vs Source-to-drain voltage	8
Static drain-to-source on-state resistance	vs Gate-to-source voltage	9
Gate-to-source threshold voltage	vs Junction temperature	10
Gate-to-source voltage	vs Gate charge	11

TPS1101, TPS1101Y SINGLE P-CHANNEL ENHANCEMENT-MODE MOSFETS

SLVS079C – DECEMBER 1993 – REVISED AUGUST 1995

TYPICAL CHARACTERISTICS

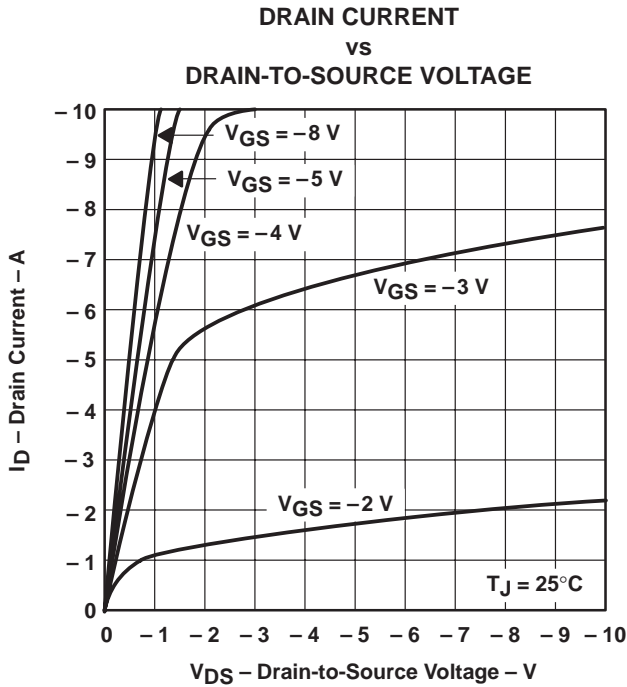

Figure 3

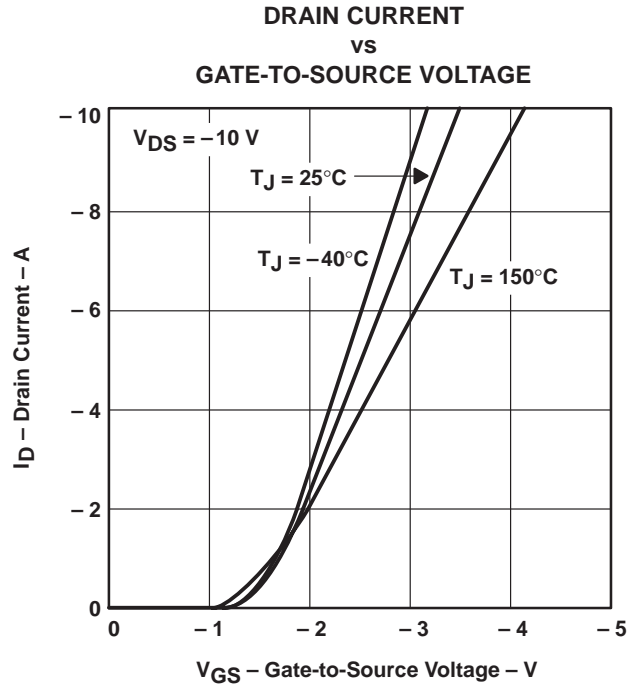

Figure 4

STATIC DRAIN-TO-SOURCE ON-STATE RESISTANCE vs DRAIN CURRENT

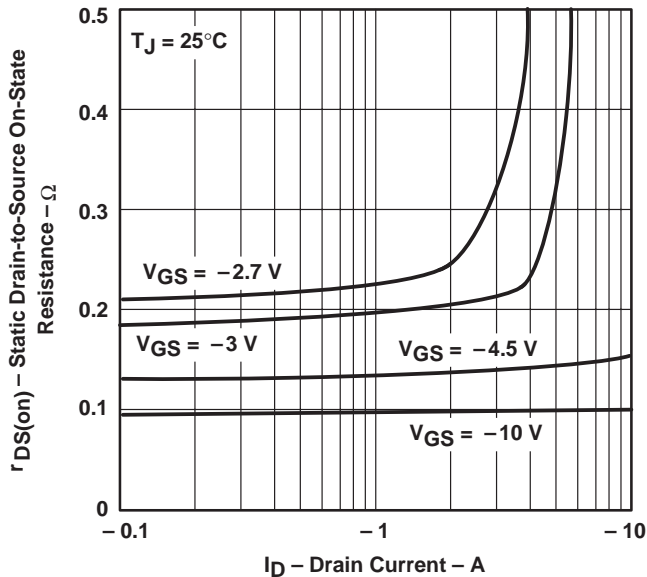
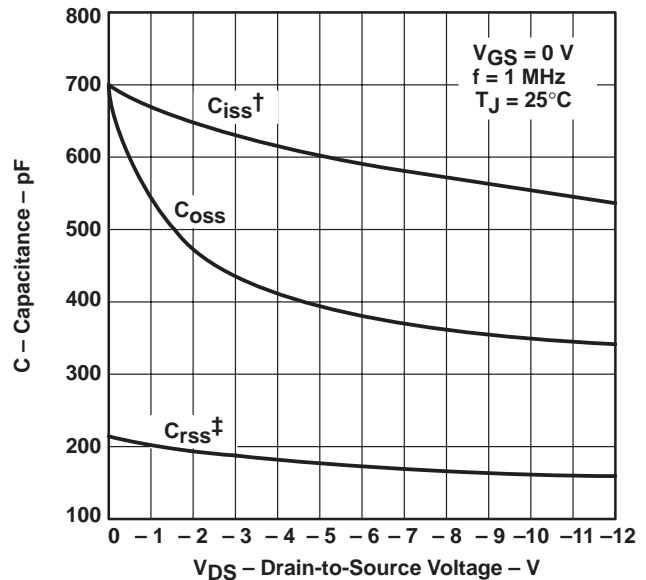

Figure 5

CAPACITANCE† vs DRAIN-TO-SOURCE VOLTAGE



$$\dagger C_{iss} = C_{gs} + C_{gd}, C_{ds(\text{shorted})}$$

$$\ddagger C_{rss} = C_{gd}, C_{oss} = C_{ds} + \frac{C_{gs} C_{gd}}{C_{gs} + C_{gd}} \approx C_{ds} + C_{gd}$$

Figure 6

TYPICAL CHARACTERISTICS

STATIC DRAIN-TO-SOURCE
ON-STATE RESISTANCE (NORMALIZED)
vs
JUNCTION TEMPERATURE

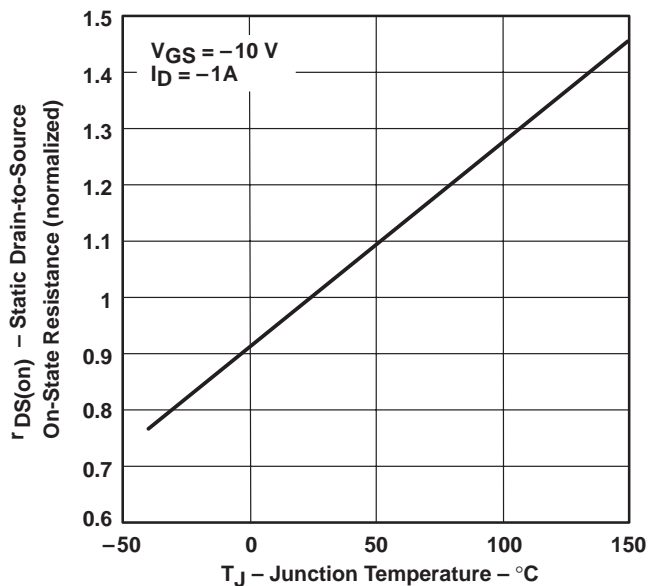

Figure 7

SOURCE-TO-DRAIN DIODE CURRENT
vs
SOURCE-TO-DRAIN VOLTAGE

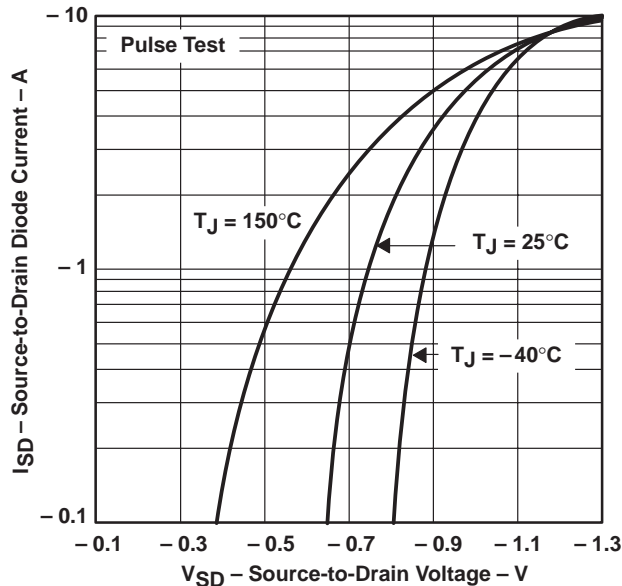

Figure 8

STATIC DRAIN-TO-SOURCE ON-STATE RESISTANCE
vs
GATE-TO-SOURCE VOLTAGE

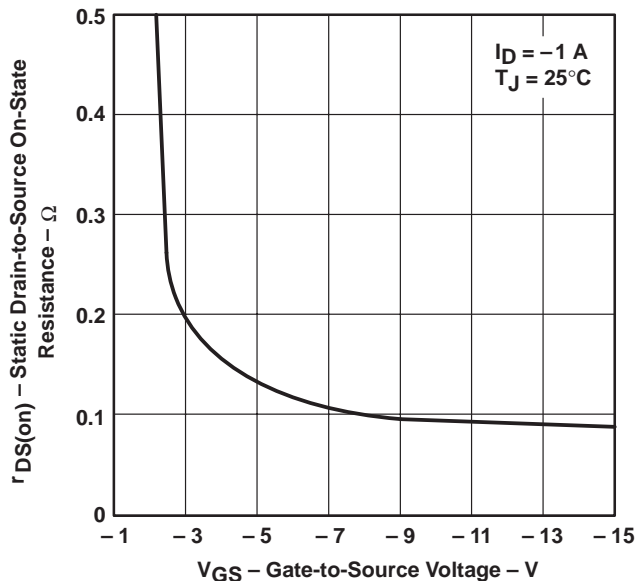

Figure 9

GATE-TO-SOURCE THRESHOLD VOLTAGE
vs
JUNCTION TEMPERATURE

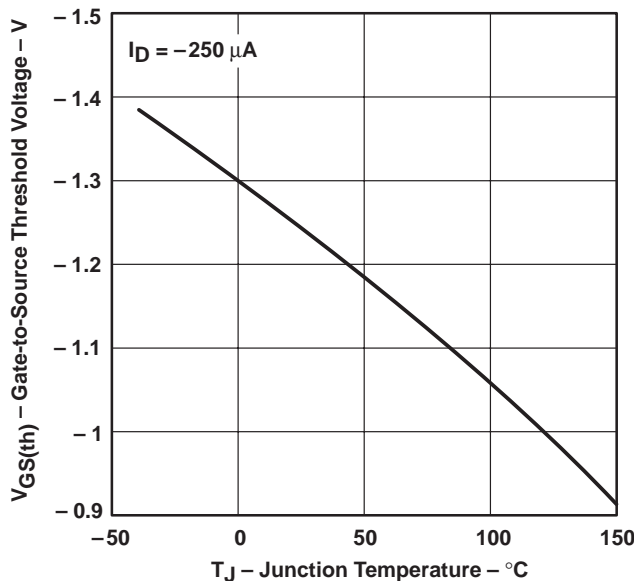

Figure 10

TPS1101, TPS1101Y SINGLE P-CHANNEL ENHANCEMENT-MODE MOSFETS

SLVS079C – DECEMBER 1993 – REVISED AUGUST 1995

TYPICAL CHARACTERISTICS

GATE-TO-SOURCE VOLTAGE
vs
GATE CHARGE

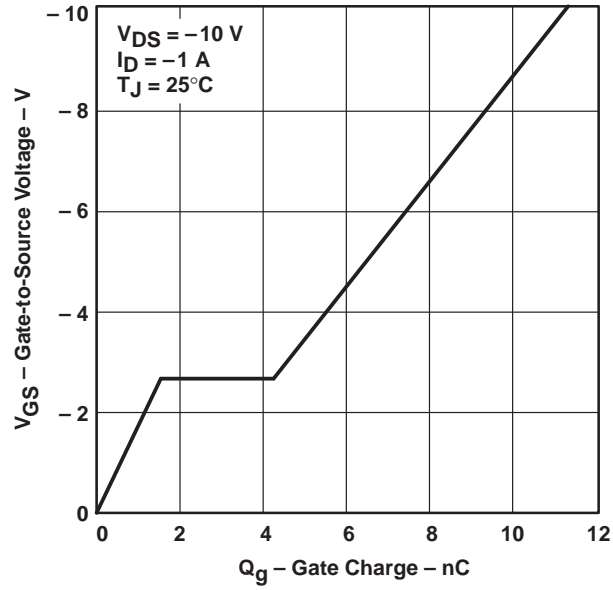
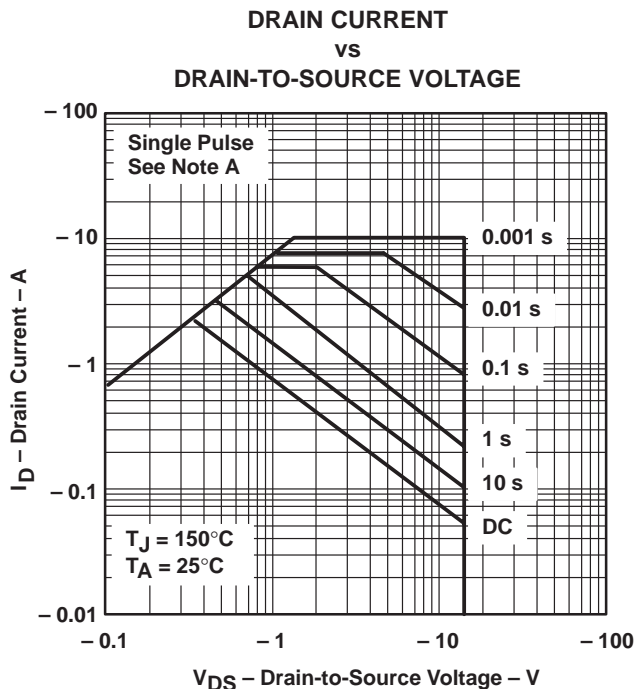

Figure 11

THERMAL INFORMATION



NOTE A: Values are for the D package and are FR4-board-mounted only.

Figure 12

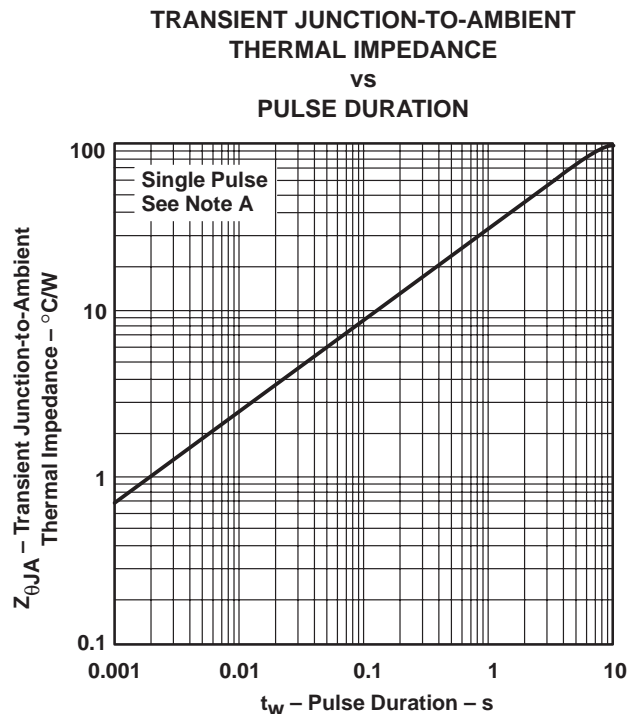

NOTE A: Values are for the D package and are FR4-board-mounted only.

Figure 13

APPLICATION INFORMATION

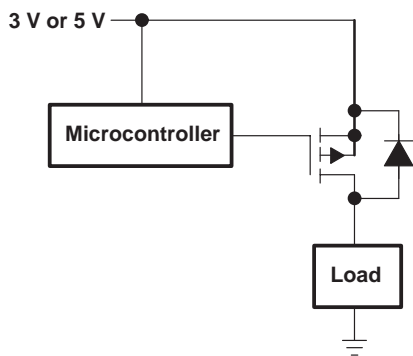

Figure 14. Notebook Load Management

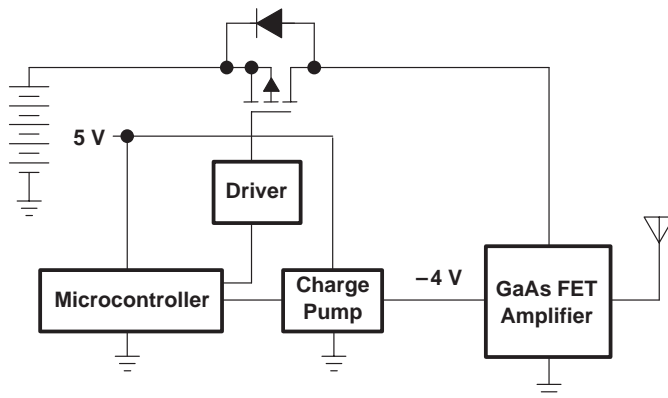

Figure 15. Cellular Phone Output Drive

PACKAGING INFORMATION

Orderable Device	Status (1)	Package Type	Package Drawing	Pins	Package Qty	Eco Plan (2)	Lead/Ball Finish (6)	MSL Peak Temp (3)	Op Temp (°C)	Device Marking (4/5)	Samples
TPS1101D	ACTIVE	SOIC	D	8	75	Green (RoHS & no Sb/Br)	CU NIPDAU	Level-1-260C-UNLIM		1101	Samples
TPS1101DG4	ACTIVE	SOIC	D	8	75	Green (RoHS & no Sb/Br)	CU NIPDAU	Level-1-260C-UNLIM		1101	Samples
TPS1101DR	ACTIVE	SOIC	D	8	2500	Green (RoHS & no Sb/Br)	CU NIPDAU	Level-1-260C-UNLIM		1101	Samples
TPS1101DRG4	ACTIVE	SOIC	D	8	2500	Green (RoHS & no Sb/Br)	CU NIPDAU	Level-1-260C-UNLIM		1101	Samples
TPS1101PWR	ACTIVE	TSSOP	PW	16	2000	Green (RoHS & no Sb/Br)	CU NIPDAU	Level-1-260C-UNLIM		PS1101	Samples

(1) The marketing status values are defined as follows:

ACTIVE: Product device recommended for new designs.

LIFEBUY: TI has announced that the device will be discontinued, and a lifetime-buy period is in effect.

NRND: Not recommended for new designs. Device is in production to support existing customers, but TI does not recommend using this part in a new design.

PREVIEW: Device has been announced but is not in production. Samples may or may not be available.

OBSOLETE: TI has discontinued the production of the device.

(2) Eco Plan - The planned eco-friendly classification: Pb-Free (RoHS), Pb-Free (RoHS Exempt), or Green (RoHS & no Sb/Br) - please check <http://www.ti.com/productcontent> for the latest availability information and additional product content details.

TBD: The Pb-Free/Green conversion plan has not been defined.

Pb-Free (RoHS): TI's terms "Lead-Free" or "Pb-Free" mean semiconductor products that are compatible with the current RoHS requirements for all 6 substances, including the requirement that lead not exceed 0.1% by weight in homogeneous materials. Where designed to be soldered at high temperatures, TI Pb-Free products are suitable for use in specified lead-free processes.

Pb-Free (RoHS Exempt): This component has a RoHS exemption for either 1) lead-based flip-chip solder bumps used between the die and package, or 2) lead-based die adhesive used between the die and leadframe. The component is otherwise considered Pb-Free (RoHS compatible) as defined above.

Green (RoHS & no Sb/Br): TI defines "Green" to mean Pb-Free (RoHS compatible), and free of Bromine (Br) and Antimony (Sb) based flame retardants (Br or Sb do not exceed 0.1% by weight in homogeneous material)

(3) MSL, Peak Temp. - The Moisture Sensitivity Level rating according to the JEDEC industry standard classifications, and peak solder temperature.

(4) There may be additional marking, which relates to the logo, the lot trace code information, or the environmental category on the device.

(5) Multiple Device Markings will be inside parentheses. Only one Device Marking contained in parentheses and separated by a "~" will appear on a device. If a line is indented then it is a continuation of the previous line and the two combined represent the entire Device Marking for that device.

⁽⁶⁾ Lead/Ball Finish - Orderable Devices may have multiple material finish options. Finish options are separated by a vertical ruled line. Lead/Ball Finish values may wrap to two lines if the finish value exceeds the maximum column width.

Important Information and Disclaimer:The information provided on this page represents TI's knowledge and belief as of the date that it is provided. TI bases its knowledge and belief on information provided by third parties, and makes no representation or warranty as to the accuracy of such information. Efforts are underway to better integrate information from third parties. TI has taken and continues to take reasonable steps to provide representative and accurate information but may not have conducted destructive testing or chemical analysis on incoming materials and chemicals. TI and TI suppliers consider certain information to be proprietary, and thus CAS numbers and other limited information may not be available for release.

In no event shall TI's liability arising out of such information exceed the total purchase price of the TI part(s) at issue in this document sold by TI to Customer on an annual basis.

TAPE AND REEL INFORMATION
REEL DIMENSIONS

TAPE DIMENSIONS

A0	Dimension designed to accommodate the component width
B0	Dimension designed to accommodate the component length
K0	Dimension designed to accommodate the component thickness
W	Overall width of the carrier tape
P1	Pitch between successive cavity centers

TAPE AND REEL INFORMATION

*All dimensions are nominal

Device	Package Type	Package Drawing	Pins	SPQ	Reel Diameter (mm)	Reel Width W1 (mm)	A0 (mm)	B0 (mm)	K0 (mm)	P1 (mm)	W (mm)	Pin1 Quadrant
TPS1101DR	SOIC	D	8	2500	330.0	12.4	6.4	5.2	2.1	8.0	12.0	Q1
TPS1101PWR	TSSOP	PW	16	2000	330.0	12.4	6.9	5.6	1.6	8.0	12.0	Q1

TAPE AND REEL BOX DIMENSIONS

*All dimensions are nominal

Device	Package Type	Package Drawing	Pins	SPQ	Length (mm)	Width (mm)	Height (mm)
TPS1101DR	SOIC	D	8	2500	340.5	338.1	20.6
TPS1101PWR	TSSOP	PW	16	2000	367.0	367.0	35.0

IMPORTANT NOTICE

Texas Instruments Incorporated (TI) reserves the right to make corrections, enhancements, improvements and other changes to its semiconductor products and services per JESD46, latest issue, and to discontinue any product or service per JESD48, latest issue. Buyers should obtain the latest relevant information before placing orders and should verify that such information is current and complete.

TI's published terms of sale for semiconductor products (<http://www.ti.com/sc/docs/stdterms.htm>) apply to the sale of packaged integrated circuit products that TI has qualified and released to market. Additional terms may apply to the use or sale of other types of TI products and services.

Reproduction of significant portions of TI information in TI data sheets is permissible only if reproduction is without alteration and is accompanied by all associated warranties, conditions, limitations, and notices. TI is not responsible or liable for such reproduced documentation. Information of third parties may be subject to additional restrictions. Resale of TI products or services with statements different from or beyond the parameters stated by TI for that product or service voids all express and any implied warranties for the associated TI product or service and is an unfair and deceptive business practice. TI is not responsible or liable for any such statements.

Buyers and others who are developing systems that incorporate TI products (collectively, "Designers") understand and agree that Designers remain responsible for using their independent analysis, evaluation and judgment in designing their applications and that Designers have full and exclusive responsibility to assure the safety of Designers' applications and compliance of their applications (and of all TI products used in or for Designers' applications) with all applicable regulations, laws and other applicable requirements. Designer represents that, with respect to their applications, Designer has all the necessary expertise to create and implement safeguards that (1) anticipate dangerous consequences of failures, (2) monitor failures and their consequences, and (3) lessen the likelihood of failures that might cause harm and take appropriate actions. Designer agrees that prior to using or distributing any applications that include TI products, Designer will thoroughly test such applications and the functionality of such TI products as used in such applications.

TI's provision of technical, application or other design advice, quality characterization, reliability data or other services or information, including, but not limited to, reference designs and materials relating to evaluation modules, (collectively, "TI Resources") are intended to assist designers who are developing applications that incorporate TI products; by downloading, accessing or using TI Resources in any way, Designer (individually or, if Designer is acting on behalf of a company, Designer's company) agrees to use any particular TI Resource solely for this purpose and subject to the terms of this Notice.

TI's provision of TI Resources does not expand or otherwise alter TI's applicable published warranties or warranty disclaimers for TI products, and no additional obligations or liabilities arise from TI providing such TI Resources. TI reserves the right to make corrections, enhancements, improvements and other changes to its TI Resources. TI has not conducted any testing other than that specifically described in the published documentation for a particular TI Resource.

Designer is authorized to use, copy and modify any individual TI Resource only in connection with the development of applications that include the TI product(s) identified in such TI Resource. NO OTHER LICENSE, EXPRESS OR IMPLIED, BY ESTOPPEL OR OTHERWISE TO ANY OTHER TI INTELLECTUAL PROPERTY RIGHT, AND NO LICENSE TO ANY TECHNOLOGY OR INTELLECTUAL PROPERTY RIGHT OF TI OR ANY THIRD PARTY IS GRANTED HEREIN, including but not limited to any patent right, copyright, mask work right, or other intellectual property right relating to any combination, machine, or process in which TI products or services are used. Information regarding or referencing third-party products or services does not constitute a license to use such products or services, or a warranty or endorsement thereof. Use of TI Resources may require a license from a third party under the patents or other intellectual property of the third party, or a license from TI under the patents or other intellectual property of TI.

TI RESOURCES ARE PROVIDED "AS IS" AND WITH ALL FAULTS. TI DISCLAIMS ALL OTHER WARRANTIES OR REPRESENTATIONS, EXPRESS OR IMPLIED, REGARDING RESOURCES OR USE THEREOF, INCLUDING BUT NOT LIMITED TO ACCURACY OR COMPLETENESS, TITLE, ANY EPIDEMIC FAILURE WARRANTY AND ANY IMPLIED WARRANTIES OF MERCHANTABILITY, FITNESS FOR A PARTICULAR PURPOSE, AND NON-INFRINGEMENT OF ANY THIRD PARTY INTELLECTUAL PROPERTY RIGHTS. TI SHALL NOT BE LIABLE FOR AND SHALL NOT DEFEND OR INDEMNIFY DESIGNER AGAINST ANY CLAIM, INCLUDING BUT NOT LIMITED TO ANY INFRINGEMENT CLAIM THAT RELATES TO OR IS BASED ON ANY COMBINATION OF PRODUCTS EVEN IF DESCRIBED IN TI RESOURCES OR OTHERWISE. IN NO EVENT SHALL TI BE LIABLE FOR ANY ACTUAL, DIRECT, SPECIAL, COLLATERAL, INDIRECT, PUNITIVE, INCIDENTAL, CONSEQUENTIAL OR EXEMPLARY DAMAGES IN CONNECTION WITH OR ARISING OUT OF TI RESOURCES OR USE THEREOF, AND REGARDLESS OF WHETHER TI HAS BEEN ADVISED OF THE POSSIBILITY OF SUCH DAMAGES.

Unless TI has explicitly designated an individual product as meeting the requirements of a particular industry standard (e.g., ISO/TS 16949 and ISO 26262), TI is not responsible for any failure to meet such industry standard requirements.

Where TI specifically promotes products as facilitating functional safety or as compliant with industry functional safety standards, such products are intended to help enable customers to design and create their own applications that meet applicable functional safety standards and requirements. Using products in an application does not by itself establish any safety features in the application. Designers must ensure compliance with safety-related requirements and standards applicable to their applications. Designer may not use any TI products in life-critical medical equipment unless authorized officers of the parties have executed a special contract specifically governing such use. Life-critical medical equipment is medical equipment where failure of such equipment would cause serious bodily injury or death (e.g., life support, pacemakers, defibrillators, heart pumps, neurostimulators, and implantables). Such equipment includes, without limitation, all medical devices identified by the U.S. Food and Drug Administration as Class III devices and equivalent classifications outside the U.S.

TI may expressly designate certain products as completing a particular qualification (e.g., Q100, Military Grade, or Enhanced Product). Designers agree that it has the necessary expertise to select the product with the appropriate qualification designation for their applications and that proper product selection is at Designers' own risk. Designers are solely responsible for compliance with all legal and regulatory requirements in connection with such selection.

Designer will fully indemnify TI and its representatives against any damages, costs, losses, and/or liabilities arising out of Designer's non-compliance with the terms and provisions of this Notice.