

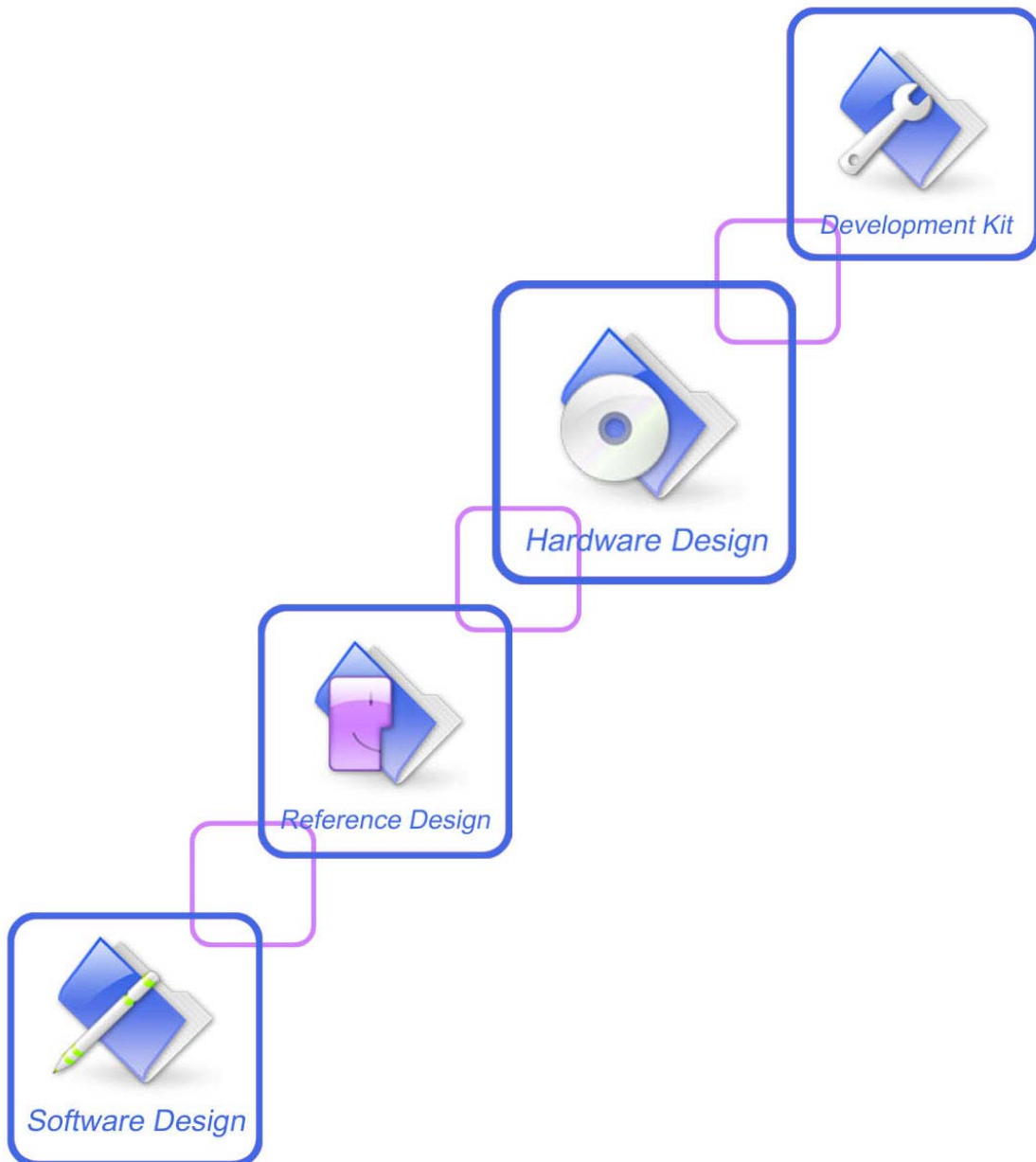

SIM6320x_Hardware Design_V1.01



Document Title	SIM6320x Hardware Design
Version	1.01
Date	2014-07-29
Status	Release
Document Control ID	SIM6320x_Hardware Design_V1.01

General Notes

SIMCom offers this information as a service to its customers, to support application and engineering efforts that use the products designed by SIMCom. The information provided is based upon requirements specifically provided to SIMCom by the customers. SIMCom has not undertaken any independent search for additional relevant information, including any information that may be in the customer's possession. Furthermore, system validation of this product designed by SIMCom within a larger electronic system remains the responsibility of the customer or the customer's system integrator. All specifications supplied herein are subject to change.

Copyright

This document contains proprietary technical information which is the property of SIMCom Limited, copying of this document and giving it to others and the using or communication of the contents thereof, are forbidden without express authority. Offenders are liable to the payment of damages. All rights reserved in the event of grant of a patent or the registration of a utility model or design. All specification supplied herein are subject to change without notice at any time.

Copyright © Shanghai SIMCom Wireless Solutions Ltd. 2014

Contents

Revision History	9
1 Introduction	10
1.1 Product Outline	10
1.2 Hardware Interface Overview	10
1.3 SIM6320x information	11
1.4 Hardware Diagram.....	11
1.5 Functional Overview.....	12
2 Package Information	13
2.1 Pin Configuration.....	13
2.2 Pin description	15
2.3 Package Dimensions.....	17
2.4 Footprint Recommendation	19
3 Application Interface Specification.....	20
3.1 Power Supply.....	20
3.1.1 Power Supply Pin.....	20
3.1.2 Design Guide	20
3.1.3 RTC Backup.....	22
3.2 Power on/off Time Sequence	23
3.2.1 Power on Sequence	23
3.2.2 Power off Sequence	25
3.3 UART Interface.....	26
3.3.1 Pin Description.....	28
3.3.2 UART Multiplexing Function.....	28
3.3.3 Application Guide	28
3.4 Audio Interfaces.....	29
3.4.1 Pin Description.....	30
3.4.2 Design Guide	30
3.4.3 Audio Parameter Characteristic	31
3.5 UIM Interface	32
3.5.1 Pin description	32
3.5.2 Application Guide.....	33
3.5.3 Recommend Components	34
3.6 I2C Interface	34
3.6.1 Pin Description.....	35
3.6.2 Signal Description.....	35
3.6.3 Design Guide	35
3.7 Keypad Interface.....	35
3.7.1 Pin Description.....	35
3.7.2 Application Guide.....	36
3.8 USB Interface	37
3.8.1 Application Guide.....	37

3.9	SPI Interface	38
3.9.1	Pin Description.....	38
3.10	GPIO Interface	38
3.10.1	Pin Description	38
3.10.2	Application Guide	39
3.11	PCM Interface	41
3.11.1	Pin Description	41
3.11.2	Signal Description	42
3.11.3	PCM Multiplexing Function.....	45
3.12	Sink Current Source	45
3.13	Reset Function.....	46
3.14	ADC	46
3.15	LDO.....	48
3.16	GPS (Only SIM6320).....	48
3.16.1	Technical specification	48
3.16.2	Operate Mode	48
3.16.3	Application Guide	49
4	RF Specification.....	51
4.1	RF Specification	51
4.2	Antenna Design Guide.....	51
5	Reliability and Operating Characteristics.....	53
5.1	Electronic Characteristics	53
5.2	Operating Mode.....	54
5.2.1	Operating Modes Overview.....	54
5.2.2	Minimize Power Consumption	55
5.3	EMC and ESD Notes	56
5.4	Current Consumption.....	57
6	Guide for Production.....	58
6.1	Top and Bottom View of SIM6320x.....	58
6.2	Typical Solder Reflow Profile	58
6.3	Moisture Sensitivity Level (MSL).....	59
6.4	Stencil Foil Design Recommendation	59
Appendix	60
A.	System Design.....	60
B.	SIM6320x GPIOs List.....	61
C.	Terms and Abbreviations	62
D.	Related Documents	64
E.	Safety Caution	65

Table Index

Table 1: Module information	11
Table 2: General Feature.....	12
Table 3: Pin definition	14
Table 4: Pin description	15
Table 5: Pin description	20
Table 6: Power on timing.....	24
Table 7: Power off timing	25
Table 8: Pin description	28
Table 9: Logic level	28
Table 10: UART multiplexing function	28
Table 11: Pin description	30
Table 12: MIC input characteristics.....	30
Table 13: Audio output characteristics.....	30
Table 14: Speaker output characteristics	30
Table 15: Audio parameter.....	31
Table 16: Electronic characteristic.....	32
Table 17: Pin description	33
Table 18: Amphenol UIM socket pin description.....	34
Table 19: Pin description	35
Table 20: Pin description	35
Table 21: Keypad Multiplexing Function.....	36
Table 22: USB Pin Description.....	37
Table 23: Pin Description	38
Table 24: Electronic characteristic.....	38
Table 25: Pin description	38
Table 26: GPIOs Electronic characteristic.....	39
Table 27: LED status	40
Table 28: Control status.....	40
Table 29: Pin description	41
Table 30: Electronic characteristic.....	41
Table 31: Timing parameters	43
Table 32: Timing parameters	44
Table 33: PCM multiplexing function	45
Table 34: Electronic characteristic.....	45
Table 35: Electronic Characteristics	46
Table 36: Electronic characteristic.....	48
Table 37: Conducted transmission power.....	51
Table 38: Operating frequencies.....	51
Table 39: Conducted receive sensitivity	51
Table 40: Absolute maximum ratings.....	53
Table 41: Recommended operating conditions.....	53
Table 42: Operating temperature	53

Table 43: Digital I/O characteristics	54
Table 44: Overview of operating modes	55
Table 46: The ESD performance measurement table (Temperature: 25°C, Humidity: 45%)	56
Table 45: Current consumption(VBAT=3.8V)	57
Table 47: Moisture sensitivity level and floor life	59
Table 48: SIM6320x GPIOs list	61
Table 49: Terms and Abbreviations	62
Table 50: Related documents	64
Table 51: Safety caution	65

Figure Index

Figure 1: SIM6320x functional architecture.....	11
Figure 2: Pin view.....	13
Figure 3: Top dimensions (Unit: mm)	18
Figure 4: Side dimensions (Unit: mm)	18
Figure 5: Bottom dimensions (Unit: mm).....	19
Figure 6: Footprint recommendation (Unit: mm).....	19
Figure 7: VBAT input application circuit	20
Figure 8: Reference circuit of the LDO power supply	21
Figure 9: Reference circuit of the DCDC power supply.....	21
Figure 10: RTC supply from capacitor	22
Figure 11: RTC supply from non-chargeable battery	22
Figure 12: RTC supply from rechargeable battery	22
Figure 13: Power on Timing Sequence.....	23
Figure 14: Application circuit.....	24
Figure 15: Power off timing sequence.....	25
Figure 16: Full modem	27
Figure 17: Null modem.....	27
Figure 18: RI behaviour in NULL Modem.....	29
Figure 19: RI behaviour in FULL Modem	29
Figure 20: Speaker interface configuration	31
Figure 21: Microphone interface configuration.....	31
Figure 22: UIM interface reference circuit.....	33
Figure 23: Amphenol C707 10M006 5122 UIM card holder	34
Figure 24: Reference circuit	36
Figure 25: USB interface.....	37
Figure 26: Application circuit.....	40
Figure 27: Flight mode switch.....	40
Figure 28: Synchrony timing.....	42
Figure 29: EXT CODEC to MODULE timing.....	42
Figure 30: MODULE to EXT CODEC timing.....	43
Figure 31: Synchrony timing.....	43
Figure 32: EXT CODEC to MODULE timing.....	44
Figure 33: MODULE to EXT CODEC timing	44
Figure 34: Current drive	46
Figure 35: Reset circuit.....	46
Figure 36: ADC1 Reference circuit	47
Figure 37: ADC2 Reference circuit	47
Figure 38: Active antenna circuit.....	50
Figure 39: Passive antenna circuit (Default).....	50
Figure 40: Antenna matching circuit	51
Figure 41: Top and bottom view of SIM6320x	58
Figure 42: The ramp-soak-spike reflow profile of SIM6320x.....	59

Figure 43: System design 60

SIMCOM CONFIDENTIAL FILE

Revision History

Data	Version	Description of change	Author
2014.07.29	1.01	Add GPS	Song.jialin

SIMCOM CONFIDENTIAL FILE

1 Introduction

This document describes electronic specifications, RF specifications, function interface, mechanical characteristic and testing conclusions of the SIMCom SIM6320x module. With the help of this document and other SIM6320x software application notes, customer guides, customers can quickly understand and use SIM6320x module to design and develop applications quickly.

1.1 Product Outline

Designed for global market, SIM6320x is a single-band CDMA2000 that works on 800MHz frequencies of CDMA 2000.

With a tiny configuration of 30*30*2.9mm and integrated functions, SIM6320x can meet almost any space requirement in customers' application, such as Smart phone, PDA phone, industrial handhelds, machine-to-machine, vehicle applications, etc..

There are 80 pins on SIM6320x, which provide most application interfaces for customers' board.

1.2 Hardware Interface Overview

Sub-interfaces are described in detail in the next chapter, which includes:

- **Power Supply**
- **USB Interface**
- **Serial Interface**
- **Analog Audio Interfaces**
- **UIM Interface**
- **GPIO**
- **ADC**
- **LDO Power Output**
- **Sink Current Source**
- **PCM Interface**
- **Keypad Interface**
- **SPI Interface**
- **RTC**
- **I2C Interface**

1.3 SIM6320x information

Table 1: Module information

	SIM6320	SIM6320C
CDMA2000 800MHz	Support	Support
GPS	Support	Not support
FLASH	1Gbit	1Gbit
DDR	256Mbit	256Mbit

1.4 Hardware Diagram

The global architecture of the SIM6320x Embedded module is described in the figure below.

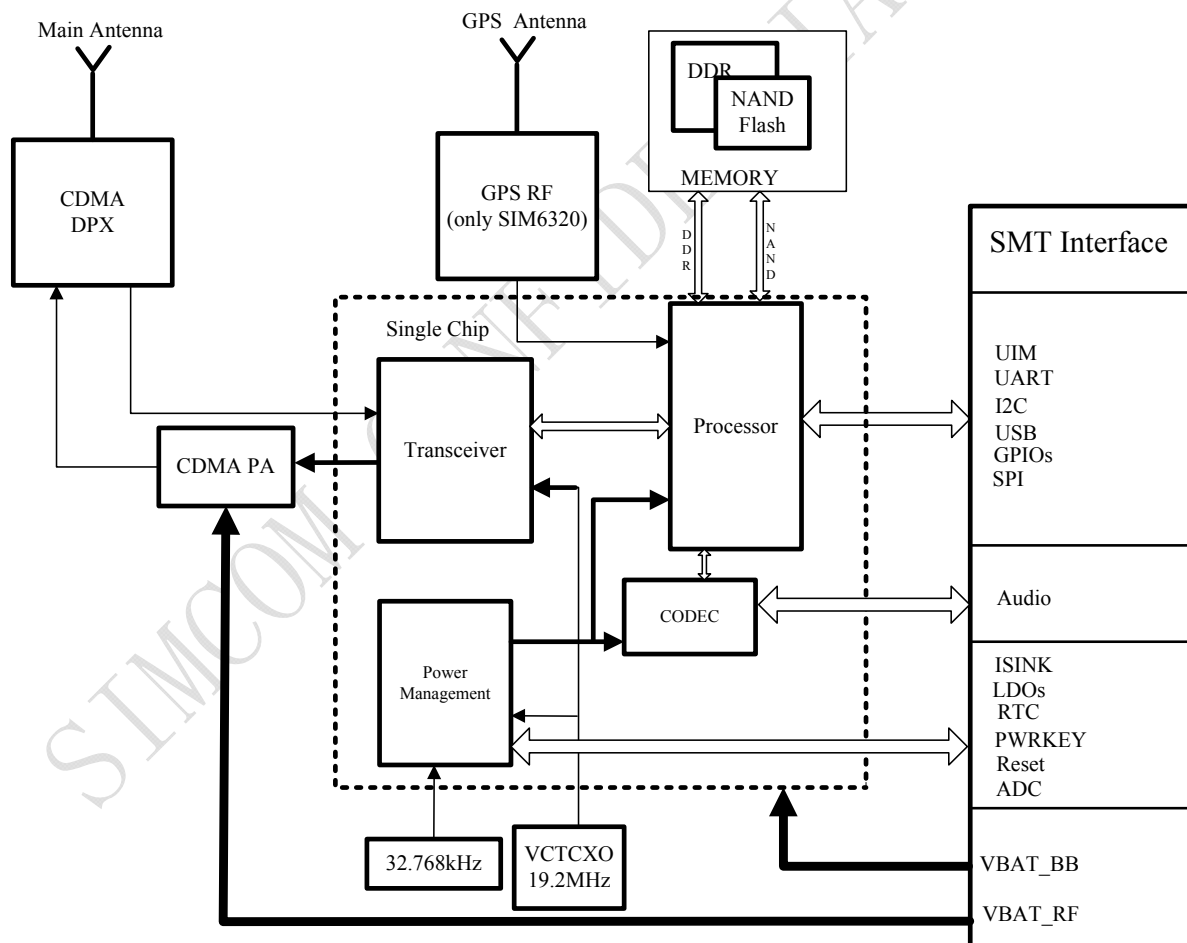

Figure 1: SIM6320x functional architecture

1.5 Functional Overview

Table 2: General Feature

Feature	Implementation
Power supply	Single supply voltage 3.3~4.2V
Transmission data	CDMA2000 EV-DO rev. A <ul style="list-style-type: none"> ● Max.3.1Mbps(DL) ● Max 1.8Mbps(UL)
SMS	<ul style="list-style-type: none"> ● Point to point MO and MT ● Support ASCII and UNICODE
UIM interface	Support identity card: 1.8V, 3V.
CDMA Protocol	<ul style="list-style-type: none"> ● IS95-A/B: Protocol Between MS & BTS ● IS-96A: Voice Signal Coding ● IS-98A:Base MS Function ● IS-126:Voice Loop-Back ● IS-637:Short Message Service ● IS-707:Data Service ● IS-657: Packet Data
Serial interface	<ul style="list-style-type: none"> ● Serial Port standard or null mode on Serial Port Interface ● Serial Port can be used to control module by sending AT command
USB	Support USB2.0 Slave mode
Phonebook management	Support phonebook types: SM, DC,FD,LD,MC,ME,RC,EN.
UIM application toolkit	<ul style="list-style-type: none"> ● Shared interface for UIM applications, thereby further supporting CDMA networks ● Selectable clock source
Real Time Clock	Support RTC
Timer function	Programmable by AT command
Physical characteristics	Size:30*30*2.9mm Weight:5.6g
Firmware upgrade	Firmware upgrade over USB interface
PCM	Multiplex on GPIOs. 3 kinds of coding formats: 8 bit (-law or A-law) and 16 bit (linear).
Temperature range	<ul style="list-style-type: none"> ● Normal operation temperature: -30°C to +80°C ● Extended operation temperature: -40°C to +85°C ● Storage temperature -40°C to +90°C

2 Package Information

2.1 Pin Configuration

All hardware interfaces which connect SIM6320x to customers' application platform are through 80 pins pads (Metal half hole). Figure 2 is SIM6320x outline diagram.

[1]:GPS_ANT(only SIM6320)

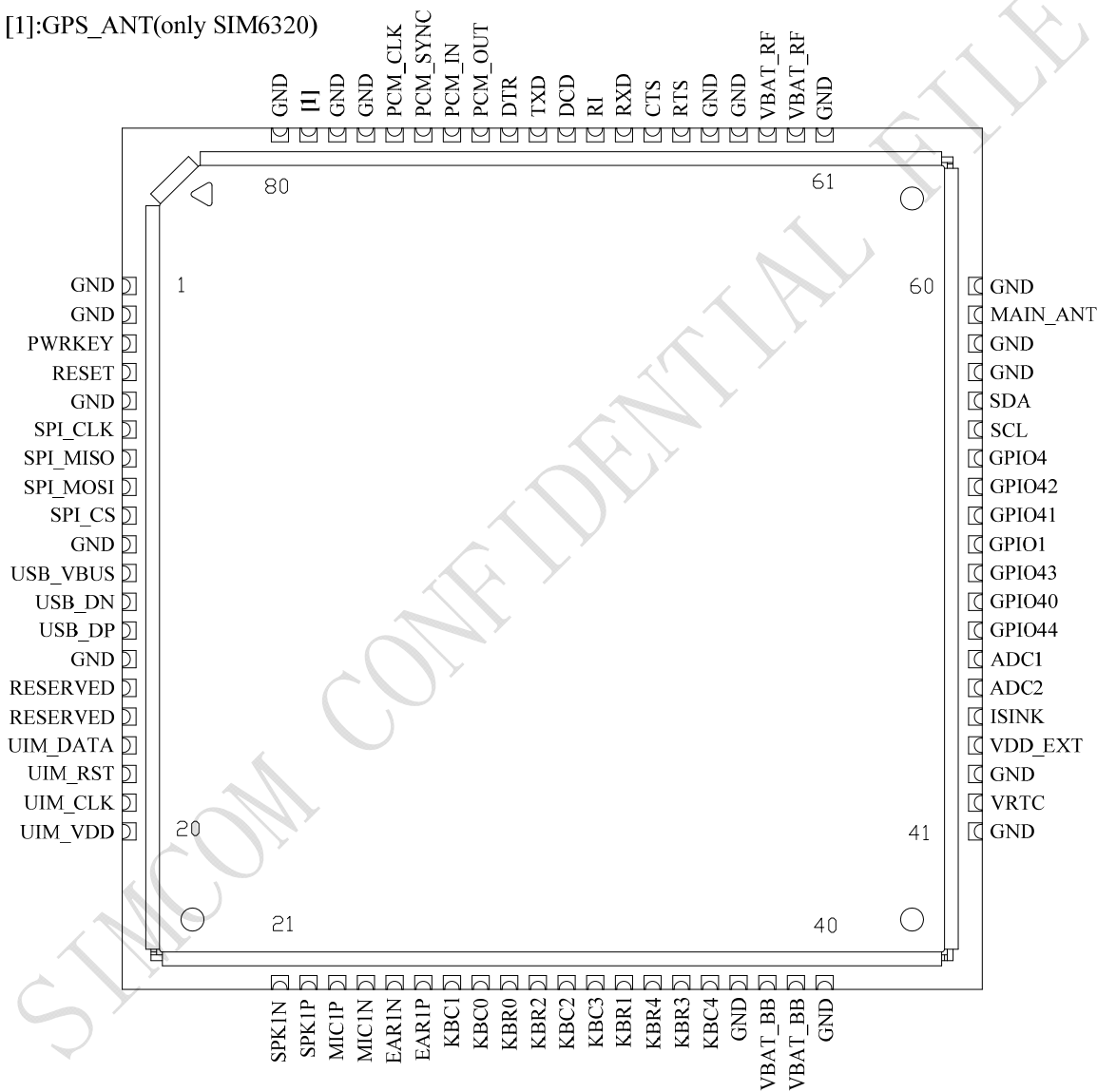

Figure 2: Pin view

Table 3: Pin definition

Pin No.	Define	Pin No.	Define
1	GND	2	GND
3	PWRKEY	4	RESET
5	GND	6	SPI_CLK
7	SPI_MISO	8	SPI_MOSI
9	SPI_CS	10	GND
11	USB_VBUS	12	USB_DN
13	USB_DP	14	GND
15	RESERVED	16	RESERVED
17	UIM_DATA	18	UIM_RST
19	UIM_CLK	20	UIM_VDD
21	SPK1N	22	SPK1P
23	MIC1P	24	MIC1N
25	EAR1N	26	EAR1P
27	KBC1	28	KBC0
29	KBR0	30	KBR2
31	KBC2	32	KBC3
33	KBR1	34	KBR4
35	KBR3	36	KBC4
37	GND	38	VBAT_BB
39	VBAT_BB	40	GND
41	GND	42	VRTC
43	GND	44	VDD_EXT
45	ISINK	46	ADC2
47	ADC1	48	GPIO44
49	GPIO40	50	GPIO43
51	GPIO1	52	GPIO41
53	GPIO42	54	GPIO4
55	SCL	56	SDA
57	GND	58	GND
59	MAIN_ANT	60	GND
61	GND	62	VBAT_RF
63	VBAT_RF	64	GND
65	GND	66	RTS

67	CTS	68	RXD
69	RI	70	DCD
71	TXD	72	DTR
73	PCM_OUT	74	PCM_IN
75	PCM_SYNC	76	PCM_CLK
77	GND	78	GND
79	GPS_ANT(only SIM6320)	80	GND

2.2 Pin description

Table 4: Pin description

Pin name	I/O	Description	Comment
Power Supply			
VBAT_RF,VBAT_BB		Power supply voltage	
VRTC	I/O	Power supply for RTC	If it is unused, keep open.
VDD_EXT	O	LDO power output	
GND		Ground	
Power on/off			
PWRKEY	I	PWRKEY should be pulled low for more than 30ms to power on or at least 1000ms to power off the module.	
Audio interface			
MIC1P	I	Differential audio input	If it is unused, connect to ground through a 100nf capacitor.
MIC1N			
EAR1P	O	Differential audio output	If these pins are unused, keep open.
EAR1N			
SPK1P	O		
SPK1N			
UIM interface			
UIM_VDD	O	Voltage Supply for SIM card Support 1.8V or 3V SIM card	All signals of SIM interface should be protected against ESD/EMC.
UIM_DATA	I/O	SIM Data Output/Input	
UIM_CLK	O	SIM Clock	
UIM_RST	O	SIM Reset	
SPI interface			
SPI_CLK	O	SPI clock	If it is unused, keep open.
SPI_CS	O	SPI chip-select	

SPI_MOSI	O	SPI (master only) master out/slave in data	
SPI_MISO	I	SPI (master only) master in/slave out data	
USB			
USB_VBUS	I	USB power supply input	
USB_DP	I/O	USB differential data I/O, (+) side.	They are compliant with the USB 2.0 specification. If it is unused, keep open.
USB_DN	I/O	USB differential data I/O, (-) side.	
Serial interface			
RXD	I	Receive Data	If it is unused, keep open.
TXD	O	Transmit Data	
RTS	O	Request to send	
CTS	I	Clear to Send	
RI	O	Ring Indicator	
DTR	I	DTE get ready	
DCD	O	Carrier detects	
I2C interface			
SDA	I/O	I2C data	Pulled up with a 2.2kR resistor to 2.6V internally. If it is unused, keep open.
SCL	O	I2C clock output	
Keypad interface			
KBR0	O	Driven keypad line	All Keypad pins can be configured as GPIOs. If it is unused, keep open.
KBR1	O	Driven keypad line	
KBR2	O	Driven keypad line	
KBR3	O	Driven keypad line	
KBR4	O	Driven keypad line	
KBC0	I	Sensed keypad line	
KBC1	I	Sensed keypad line	
KBC2	I	Sensed keypad line	
KBC3	I	Sensed keypad line	
KBC4	I	Sensed keypad line	
PCM interface			
PCM_IN	I	General Input PIN with module wake/interrupt. It also can be multiplexed as the PCM_IN pin.	If it is unused, keep open.
PCM_SYNC	I	General Input PIN. It also can be multiplexed as the PCM_SYNC pin.	
PCM_CLK	O	General Output PIN. It also can be multiplexed as the PCM_CLK pin.	
PCM_OUT	O	General Output PIN. It also can be	

		multiplexed as the PCM_OUT pin.	
GPIOs			
GPIO1	O	Output PIN as LED control for network status.	If it is unused, keep open.
GPIO4	I	Input PIN as RF operating control.	
GPIO40	O	Output PIN as operating status indicating of module.	
GPIO41	I/O	General input/output PIN. It can be used as wake/interrupt signal to host from module	
GPIO43	I/O	General input/output PIN. It can be used as wake/interrupt signal to module from host.	
GPIO44	I/O	General input/output PIN.	
GPIO42	I/O	General input/output PIN.	
Other interface			
RESET	I	System reset in, active low.	If it is unused, keep open.
ISINK	I	Current source of ground-referenced current sink	If it is unused, keep open.
ADC1	I	Analog Digital Converter Input	If it is unused, keep open.
ADC2	I	Battery temperature ADC input pin	
MAIN_ANT	I/O	ANT soldering pad	
GPS_ANT	I/O	GPS Antenna	Only SIM6320

2.3 Package Dimensions

The following figure shows mechanical dimensions of SIM6320x.

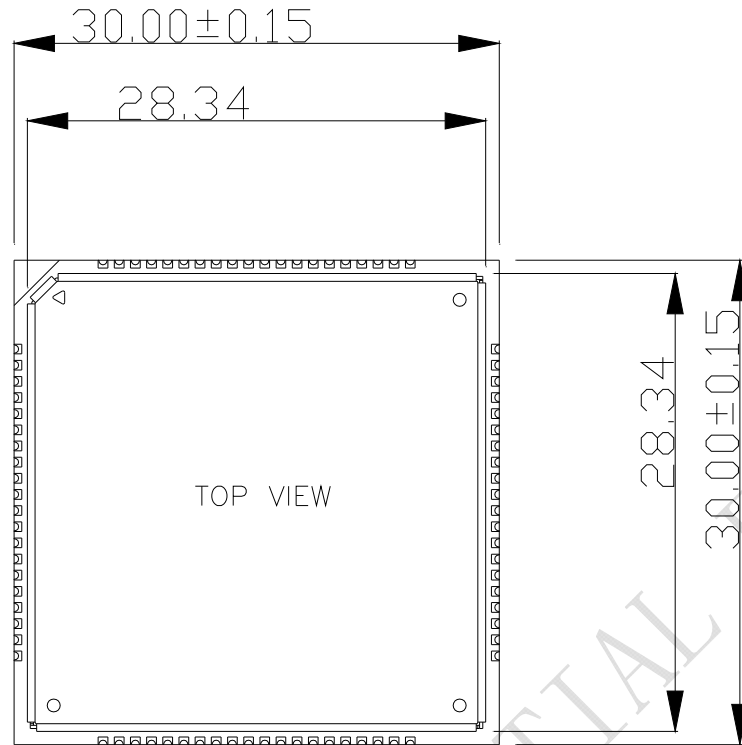

Figure 3: Top dimensions (Unit: mm)

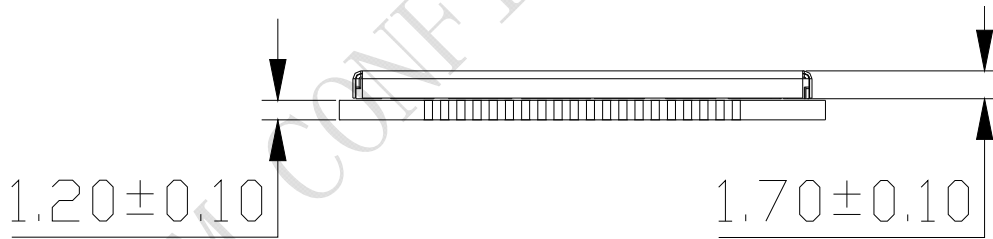

Figure 4: Side dimensions (Unit: mm)

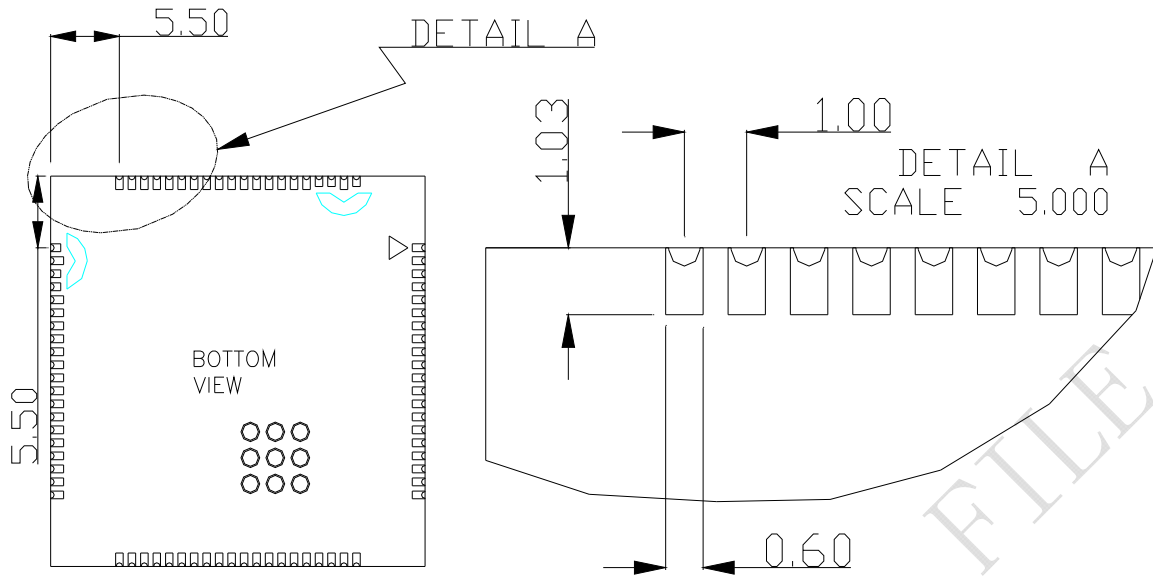
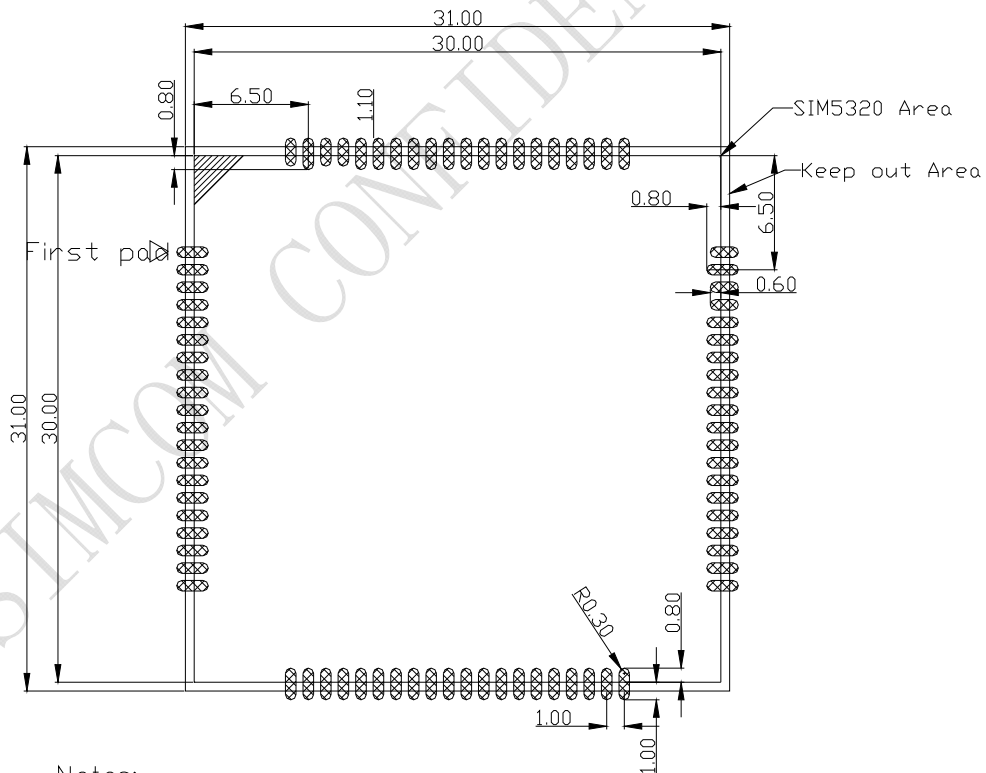

Figure 5: Bottom dimensions (Unit: mm)

2.4 Footprint Recommendation



Notes:
Silk screen and copper exposure are not allowed in the Keep out Area.

Figure 6: Footprint recommendation (Unit: mm)

3 Application Interface Specification

3.1 Power Supply

The power supply pins of SIM6320x include VBAT_RF and VBAT_BB. VBAT_RF directly supplies the power to RF PA; VBAT_BB supplies the power to the baseband system. VBAT_RF power supply must be able to provide sufficient current up to 1A.

3.1.1 Power Supply Pin

Two VBAT_RF and two VBAT_BB pins are dedicated to connect the supply voltage.

Table 5: Pin description

Pin type	Pin name	Min	Typ	Max	Unit
POWER	VBAT_RF	3.3	3.8	4.2	V
	VBAT_BB	3.3	3.8	4.2	V

Note: Though the VBAT_RF and VBAT_BB are supplied by the same voltage level, they are different pins. VBAT_RF is for RF section and VBAT_BB is for baseband system.

3.1.2 Design Guide

Mostly, customer connects the VBAT_RF and VBAT_BB pins with one power supply. For the consideration of RF performance and system stability, another large capacitor (above 100uF) should be located at the VBAT_RF pin and some multi-layer ceramic chip (MLCC) capacitors (0.1uF) need to be used for EMC because of their low ESR in high frequencies. (Note that capacitors should be put beside VBAT_RF pins as close as possible) Also Customer should minimize the PCB trace impedance from the power supply to the VBAT pins through widening the trace to 80 mil or more on the board. The following figure is the recommended circuit.

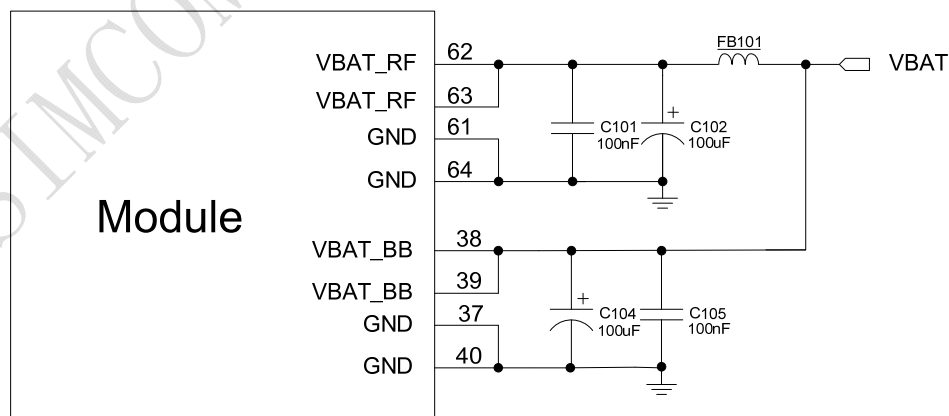

Figure 7: VBAT input application circuit

Power supply circuit

We recommend DCDC or LDO is used for the power supply of the module, make sure that the peak current of power components can rise up to 1A. The following figure is the reference design of +5V input power supply. The designed output for the power supply is 3.8V, here a linear regulator can be used.

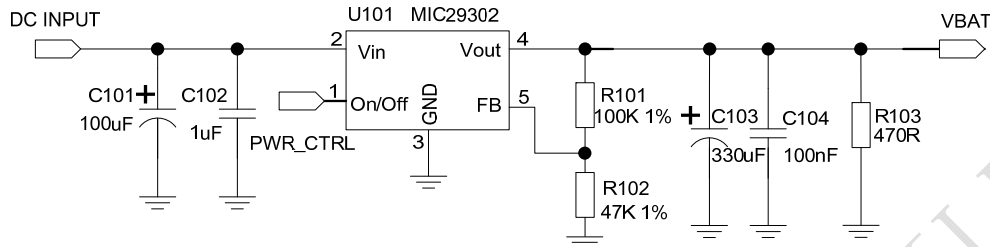

Figure 8: Reference circuit of the LDO power supply

If there is a big difference between the input voltage and the desired output (VBAT), a switching converter power will be preferable because of its better efficiency, especially at the high current situation. The following figure is the reference circuit.

Note: that DCDC may deprave RF performance because of ripple current intrinsically.

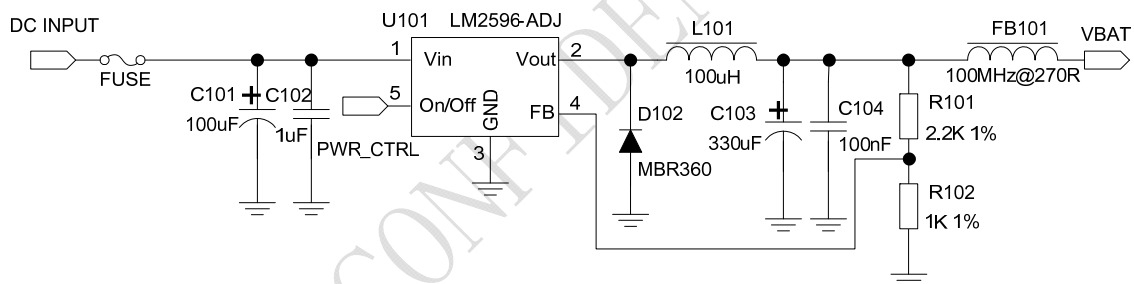

Figure 9: Reference circuit of the DCDC power supply

Voltage monitor

To monitor the power supply voltage, customer can use the AT command “AT+CBC”, this command has two parameters: the battery status and the voltage value (mV). It will return the capacity percentage and actual value of battery (at the VBAT_BB pin). The voltage is continuously measured at intervals, whenever the measured battery voltage is lower than a specific value set by the AT command “AT+CVALARM”. For example, if the voltage value is set to be 3.4V, the following URC will be presented: “warning! voltage is low: 3.3v”.

If the voltage is lower than a specific value which is set by the AT command “AT+CPMVT”, the module will be powered off automatically and AT commands cannot be executed any more.

Note: Under-voltage warning function is disabled by default, customer can enable it by the AT command “AT+CVALARM”. Auto power off feature is disabled by default, customer should set it by the AT command “AT+CPMVT” to an appropriate value. Please refer to Document [1].

3.1.3 RTC Backup

The module uses RTC (Real Time Clock) to update and maintain inherent time and keeps system alive at no power supply status. The RTC power supply of module can be provided by an external capacitor or a battery (non-chargeable or rechargeable) through the VRTC. The following figures show various reference circuits for RTC back up. The discharge current is less than 10uA. If this feature is used, please refer to the AT commands “AT+CTZU” and “AT+CTZR”.

- **External capacitor backup**

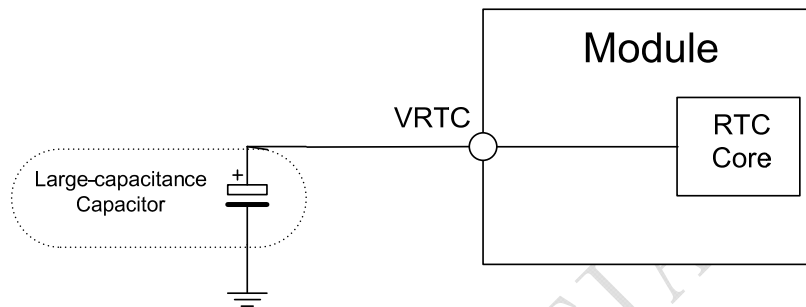

Figure 10: RTC supply from capacitor

- **Non-chargeable battery backup**

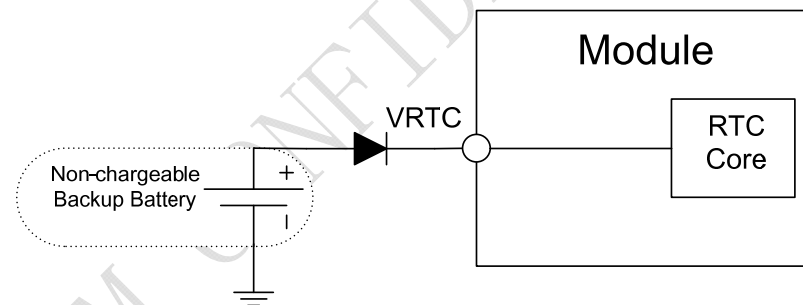

Figure 11: RTC supply from non-chargeable battery

- **Rechargeable battery backup**

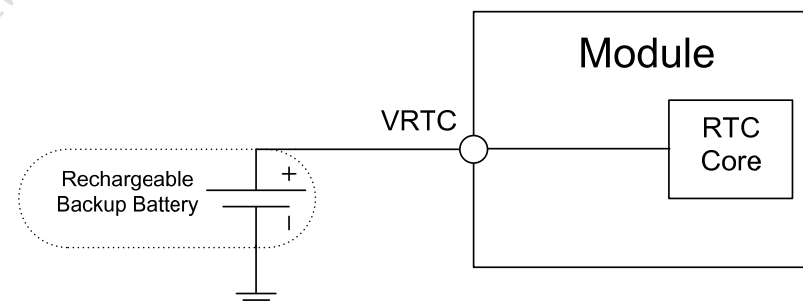

Figure 12: RTC supply from rechargeable battery

Note: The VRTC can be disabled, jus disconnect it in application circuit.

3.2 Power on/off Time Sequence

3.2.1 Power on Sequence

SIM6320x can be powered on by PWRKEY pin, which starts normal operating mode. PWRKEY pin is pulled up with a 200k resistor to 2.8V in module. Customer can power on the SIM6320x by pulling the PWRKEY pin down for a short time. The power on scenarios are illustrated in the following figures.

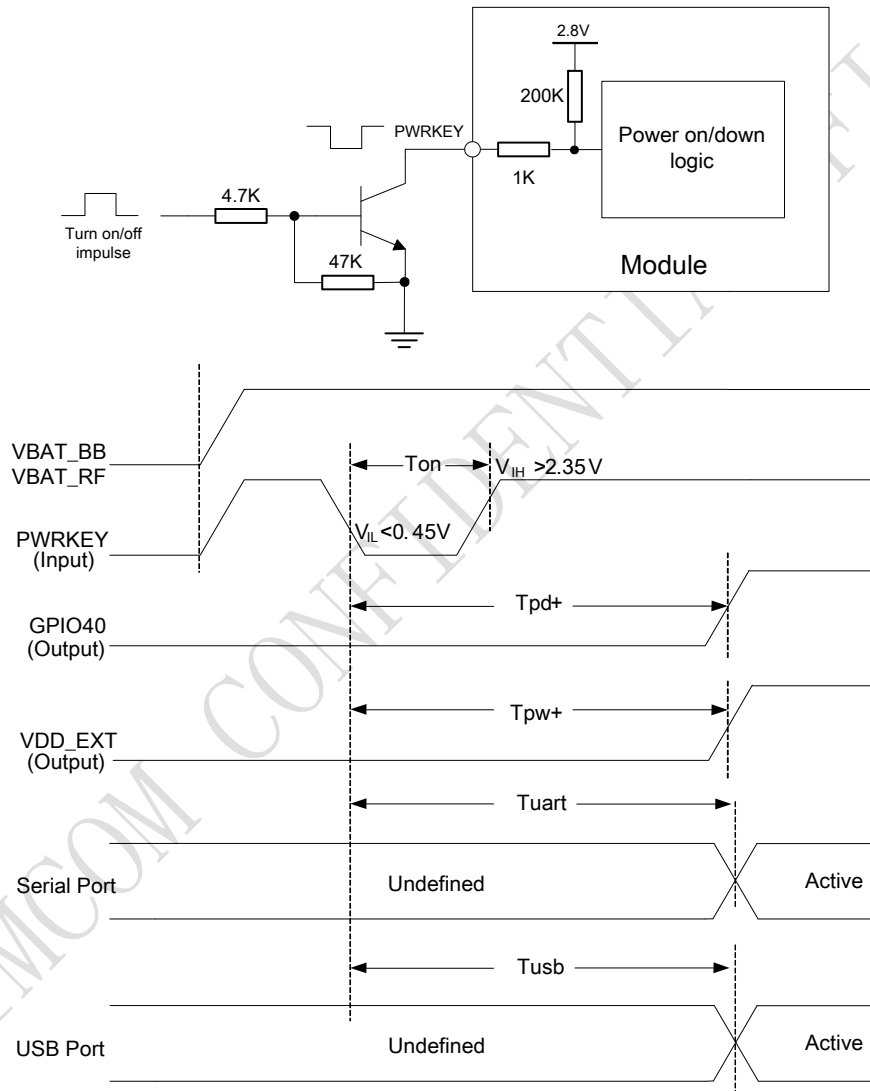

Figure 13: Power on Timing Sequence

Table 6: Power on timing

Parameter	Description	Time value	Unit
Ton	The time to pull PWRKEY down to power on	>30	ms
TpD+	The time to indicate connecting with the network	>5.5	s
Tpw+	The time to indicate the module is powered on completely	>4.5	s
Tuart	The time to enable UART	>4.7	s
Tusb	The time to enable USB	>9	s

Automatic power on

If customer needs to power on SIM6320x automatically whenever the VBAT pins are connected to the power supply, then PWRKEY pin is just pulled to ground by a resistance in circuit directly. The following is the reference circuit.

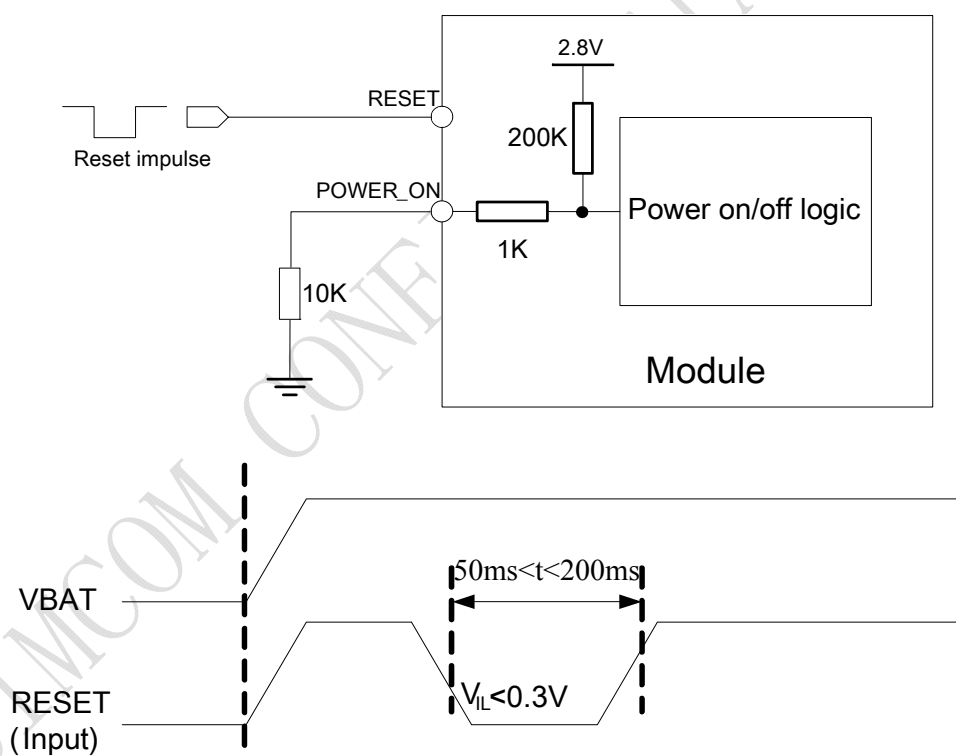

Figure 14: Application circuit

Note:

1. After automatically powering on the module by pulling down PWRKEY pin to ground anytime, USB/UART may not communicate normally with host, so it is suggested that SIM6320x should be reset by RESET pin.
2. Please refer to the chapter 3.13 in detail about the reset function.

3.2.2 Power off Sequence

The following methods can be used to power down SIM6320x. These procedures will make module disconnect from the network and allow the software to enter a safe state, and then save data before completely powering the module off.

- Power off SIM6320x by pulling the PWRKEY pin down
- Power off SIM6320x by AT command
- Abnormal power down: under-voltage automatic power down.
- Abnormal power down: over-temperature or under-temperature automatic power down.

Note: Under-voltage warning function and auto power off feature is disabled by default.

Customer can power off the SIM6320x by pulling PWRKEY down for a specific time. The power off scenario is illustrated in the following figure.

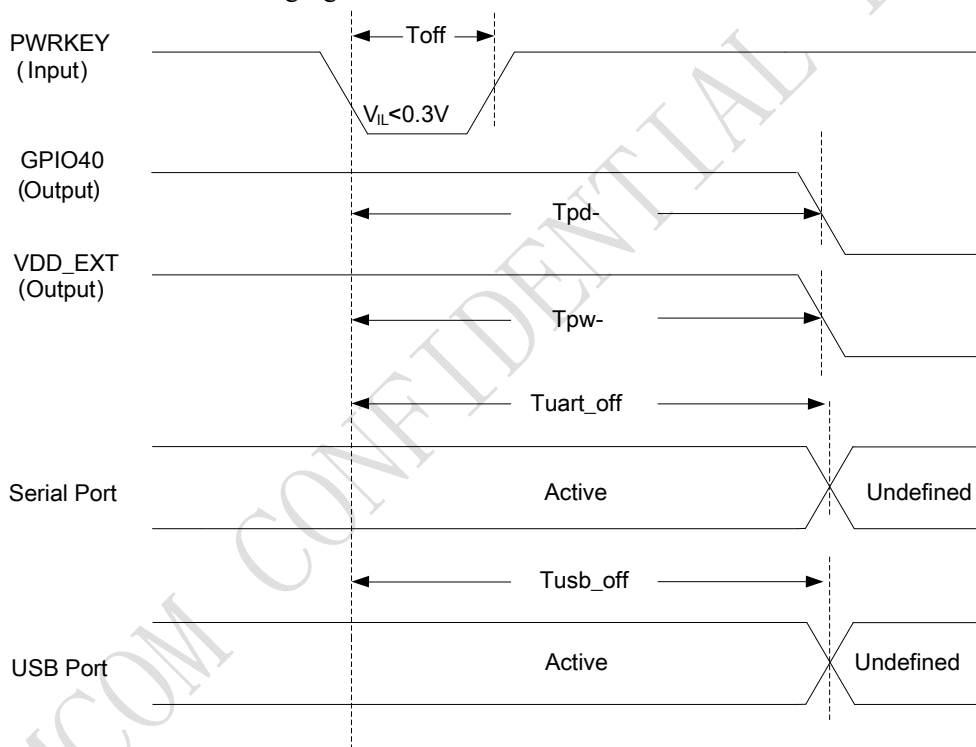

Figure 15: Power off timing sequence

Table 7: Power off timing

Parameter	Description	Time value	Unit
T_{off}	The time pulling PWRKEY down to power off	$1 < T_{off} < 5$	s
T_{pd-}	The time to indicate disconnecting from the network	> 7	s
T_{pw-}	The time to indicate the module power off completely	> 7.5	s
T_{uart_off}	The time to disable UART	> 6	s
T_{usb_off}	The time to disable USB	> 7.5	s

Customer can also use the AT command “AT+CPOF” to power down the module. After that, the AT

commands cannot be executed any longer. The module enters the POWER DOWN mode, only the RTC is still active. For details, refer to *Document [1]*.

3.2.2.1 Under-voltage Power down

The module software monitors the VBAT voltage constantly.

If the voltage $\leq 3.3V$, the following URC will be reported:

UNDER-VOLTAGE WARNING

If the voltage $< 2.8V$, the module will be automatically powered down.

At this moment, AT commands can not be executed any more, and only the RTC is still active. Power down mode can also be indicated by GPIO40(STATUS) pin, which is at low level at this time.

3.2.2.2 Over-temperature or Under-temperature Power down

The module will constantly monitor the temperature of the module.

If the temperature $> +75^{\circ}C$, the following URC will be reported:

+CMTE: 1

If the temperature $< -25^{\circ}C$, the following URC will be reported:

+CMTE:-1

If the temperature $> +80^{\circ}C$, the following URC will be reported, and the module will be automatically powered down.

+CMTE: 2

If the temperature $< -30^{\circ}C$, the following URC will be reported, and the module will be automatically powered down.

+CMTE:-2

The AT command "AT+CMTE" could be used to read the temperature when the module is running.

For details refer to *document [1]*.

3.3 UART Interface

SIM6320x provides a UART (universal asynchronous serial transmission) port. It consists of a flexible 7-wire serial interface. The module is as the DCE (Data Communication Equipment) and the client PC is as the DTE (Data Terminal Equipment). AT commands are entered and serial communication is performed through UART interface. The application circuit is in the following figures.

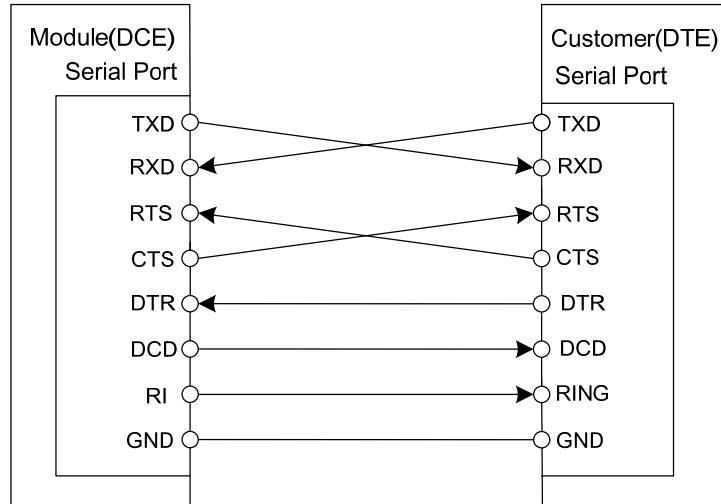

Figure 16: Full modem

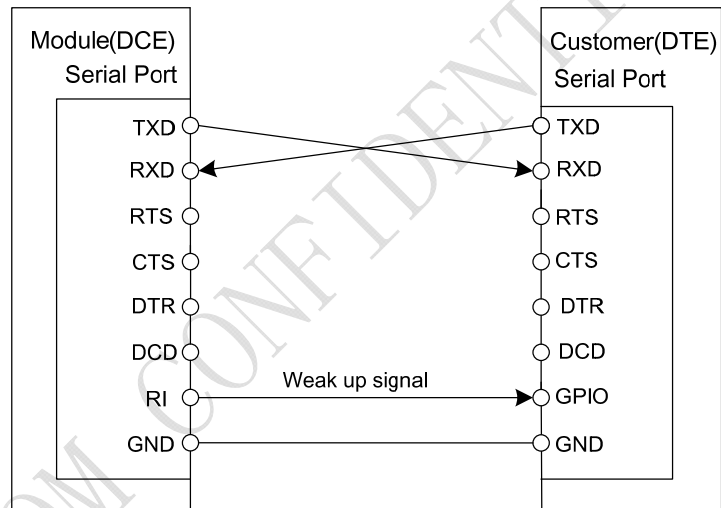

Figure 17: Null modem

3.3.1 Pin Description

Table 8: Pin description

Pin type	Pin name	Pin No.	I/O	Reset Status
UART	RXD	68	I	
	TXD	71	O	
	RTS	66	O	Pull-Up
	CTS	67	I	Pull-Down
	DTR	72	I	Pull-Up
	DCD	70	O	Pull-Down
	RI	69	O	Pull-Down

Table 9: Logic level

Parameter	Parameter	Min	Typ	Max	Unit
V _{IL}	Low-level input voltage	-0.3	-	0.91	V
V _{IH}	High-level input voltage	1.69	-	2.9	V
V _{OL}	Low-level output voltage	0	-	0.45	V
V _{OH}	High-level output voltage	2.15	-	2.6	V

3.3.2 UART Multiplexing Function

Table 10: UART multiplexing function

Pin name	Pin number	Mode 0(default)	Mode 1
CTS	67	CTS	GPIO33
RTS	66	RTS	GPIO34
DTR	72	DTR	GPIO35
DCD	70	DCD	GPIO36
RI	69	RI	GPIO37

3.3.3 Application Guide

If UART port is used in Null Modem, the pin “RI” can be used as an interrupt signal to HOST. Normally it will keep high logic level until certain condition such as receiving SMS, voice call (CSD, video) or URC reporting, then “RI” will change to low logic level to inform the master (client PC). It will stay low until the master clears the interrupt event with AT command.

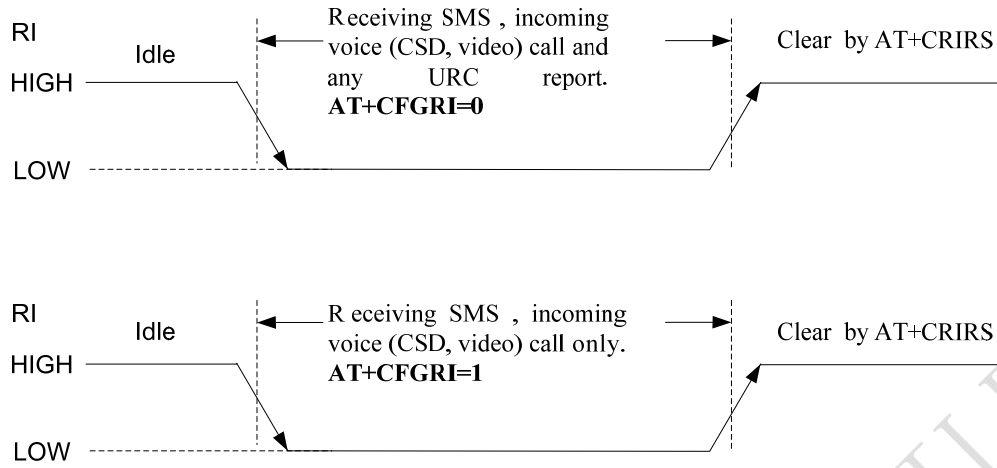

Figure 18: RI behaviour in NULL Modem

If Full Modem is used to establish communication between devices, the pin “RI” is another operation status. Initially it keeps high, when a voice call or CSD call comes, the pin “RI” will change to low for about 5900ms, then it will return to high level for 100ms. It will repeat this procedure until this call is answered or hung up.

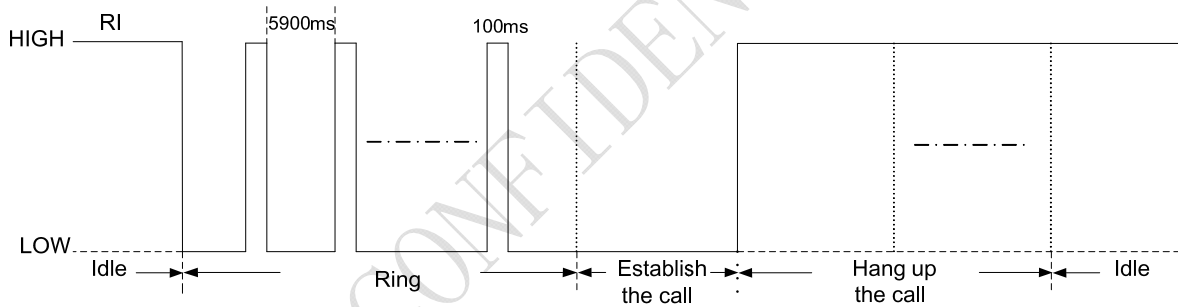

Figure 19: RI behaviour in FULL Modem

To comply with RS-232 protocol, the RS-232 level shifter chip should be used to connect SIM6320x to the RS-232-C interface. In this connection, the TTL level and RS-232 level are converted mutually. SIMCom recommends that customer uses the SP3238ECA chip with a full modem. For more information please refers to the RS-232 chip datasheet.

Note: SIM6320x supports the communication rate: 300, 600, 1200, 2400, 4800, 9600, 19200, 38400, 57600, 115200, 230400, 460800, 921600, 3200000, 3686400, 4000000bps. Default rate is 115200bps.

3.4 Audio Interfaces

SIM6320x provides two analog signal outputs and one analog input. MIC1P/N is used as microphone, EAR1P/N and SPK1P/N are used as audio output. Regarding audio parameters configuration, please refer

to document [1].

3.4.1 Pin Description

Table 11: Pin description

Audio channel	Pin name	Pin No.	Function
Normal	MIC1P	23	MIC positive input
	MIC1N	24	MIC negative input
	EAR1P	26	Receiver positive output
	EAR1N	25	Receiver negative output
Hand-free	MIC1P	23	MIC positive input
	MIC1N	24	MIC negative input
	SPK1P	22	Loudspeaker positive output
	SPK1N	21	Loudspeaker negative output

Table 12: MIC input characteristics

Parameter	Min	Typ	Max	Unit
Microphone biasing voltage	-	1.8	-	V
MIC bias current	0.02	-	1.5	mA
External Microphone Load Resistance	1.2	2.2		k Ω

Table 13: Audio output characteristics

Parameter		Min	Typ	Max	Unit	
Normal (EAR_P,EAR_N)	Differential	Load resistance	27	32	-	Ω
		Output power	-	50	-	mW

SIM6320x internal has Class-D audio amplifier, the following table is Class-D performance:

Table 14: Speaker output characteristics

Parameter	Min	Typ	Max	Unit
Input frequency range	0.02	-	20	kHz
Quiescent Current	-	-	4.2	mA
Load resistance	-	8	-	Ω
Output power(1kHz)	-	500	-	mW

3.4.2 Design Guide

There are three audio channels in SIM6320x, including speaker output , receiver output and microphone input.

SPEAKER circuit in SIM6320x is a Class-D amplifier, optional EMI filter is shown in the following figure; these components (two ferrite beads and two capacitors) can reduce electromagnetic interference. If used, they should be located beside SPK1P and SPK1N pins. Considerable current flows in the channels,

so wider PCB traces are recommended (20 mils).

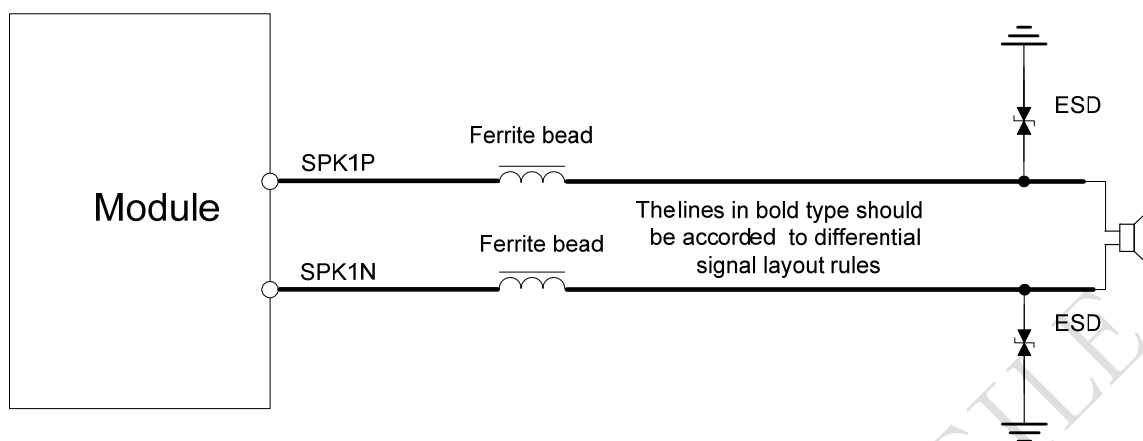

Figure 20: Speaker interface configuration

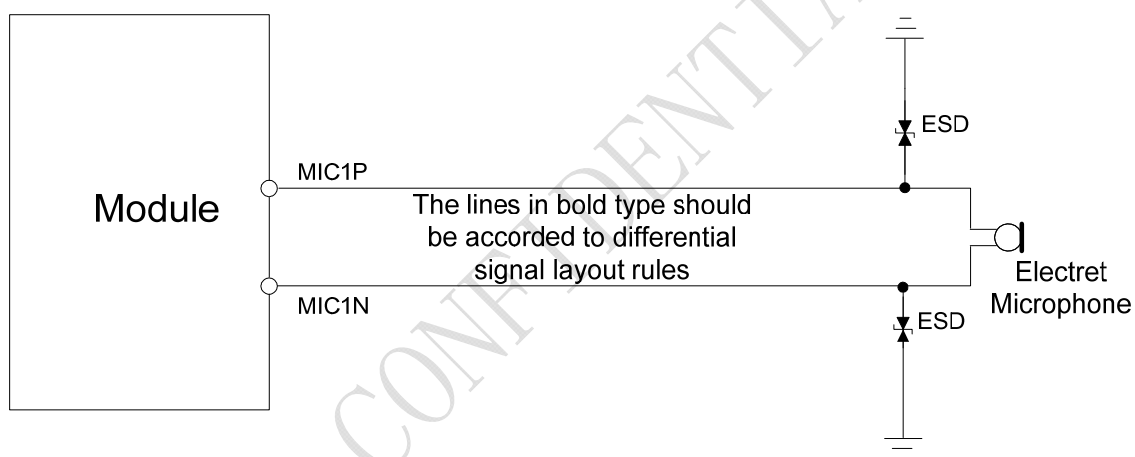

Figure 21: Microphone interface configuration

Note: SIM6320x has integrated MIC bias circuit. There is no need to pull the MIC1P and MIC1N up to the external power, just connect it to microphone. MIC1P and MIC1N must be differential lines.

3.4.3 Audio Parameter Characteristic

Main audio parameters can be changed to satisfy customers' requirement. Here primary register parameters and related description are listed. Customer can adjust them through AT command. For more detail please refers to Audio Application Document.

Table 15: Audio parameter

Parameter	Influence to	Range	Gain range	Calculation	AT command
micAmp1	MICP/MICN analogue amplifier gain before ADC	0...1	0...24dB	2 steps	AT+CMICAMP1
txVol	Digital gain of input signal after ADC	0, 1...65535	Mute, -84...+12dB	$20 * \log(\text{txVol}/16384)$	AT+CTXVOL
txGain	Digital gain of input signal after summation of side tone	0, 1...65535	Mute, -84...+12dB	$20 * \log(\text{txGain}/16384)$	AT+CTXGAIN
txFilter	Input PCM 13-tap filter parameters, 7 values	0...65535	---	MATLAB calculate	AT+CTXFTR
rxGain	Digital gain of output signal after summation of sidetone	0, 1...65535	Mute, -84...+12dB	$20 * \log(\text{rxGain}/16384)$	AT+CRXGAIN
rxVol	Digital Volume of output signal after speech decoder, before summation of sidetone and DAC	-300...300	dBm	-300...300dBm	AT+CLVL AT+CVLVL AT+CRXVOL
stGain	Digital attenuation of sidetone	0, 1...65535	Mute, -96...0dB	$20 * \log(\text{stGain}/16384) - 12$	AT+SIDET
rxFilter	Output PCM 13-tap filter parameters, 7 values	0...65535	---	MATLAB calculate	AT+CRXFTR

Note: If customers require better experience on audio, customers should modify these parameters according to their own electronic and mechanical design.

3.5 UIM Interface

The UIM provides the required subscription verification information to allow the mobile equipment to attach to a CDMA2000 network. Both 1.8V and 3.0V UIM Cards are supported.

3.5.1 Pin description

Table 16: Electronic characteristic

Pin name	3.0V mode			1.8V mode			Unit
	Min	Typ	Max	Min	Typ	Max	
UIM_VDD	2.75	2.85	2.95	1.65	1.8	2.0	V
V _{IH}	0.65* UIM_VDD	-	UIM_VDD +0.3	0.65* UIM_VDD	-	UIM_VDD +0.3	V
V _{IL}	-0.3	-	0.35* UIM_VDD	-0.3	-	0.35* UIM_VDD	V
V _{OH}	UIM_VDD -0.45	-	UIM_VDD	UIM_VDD -0.45	-	UIM_VDD	V
V _{OL}	0	-	0.45	0	-	0.45	V

Table 17: Pin description

Pin name	Pin	Description
UIM_CLK	19	UIM Card Clock
UIM_RST	18	UIM Card Reset
UIM_DATA	17	UIM Card data I/O, which has been pulled up with a 22kR resistor to UIM_VDD in module. Do not pull up or pull down in customers' application circuit.
UIM_VDD	20	UIM Card Power output depends automatically on UIM mode, one is 3.0V±10%, another is 1.8V±10%. Current is less than 50mA.

3.5.2 Application Guide

It is recommended to use an ESD protection component such as ST (www.st.com) ESDA6V-1W5 or ON SEMI (www.onsemi.com) SMF05C. Note that the UIM peripheral circuit should be close to the UIM card socket. The reference circuit of the 6-pin UIM card holder is illustrated in the following figure.

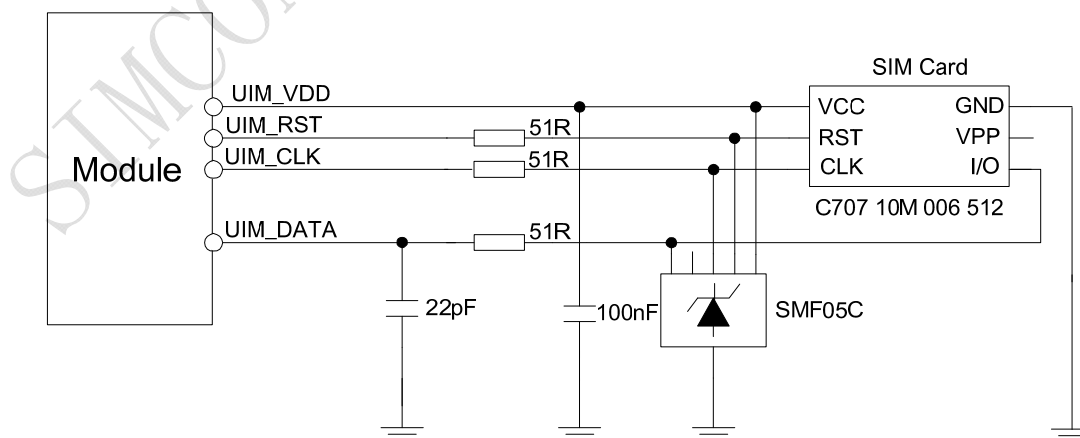

Figure 22: UIM interface reference circuit

Note: UIM_DATA has been pulled up with a 15kR resistor to UIM_VDD in module. A 100nF shut

capacitor on UIM_VDD is used to reduce interference. Use AT Commands to get information in UIM card. For more detail, refer to document [1].

3.5.3 Recommend Components

For 6 pins UIM socket, SIMCom recommend to use Amphenol **C707 10M006 512 2**. Customer can visit <http://www.amphenol.com> for more information about the holder.

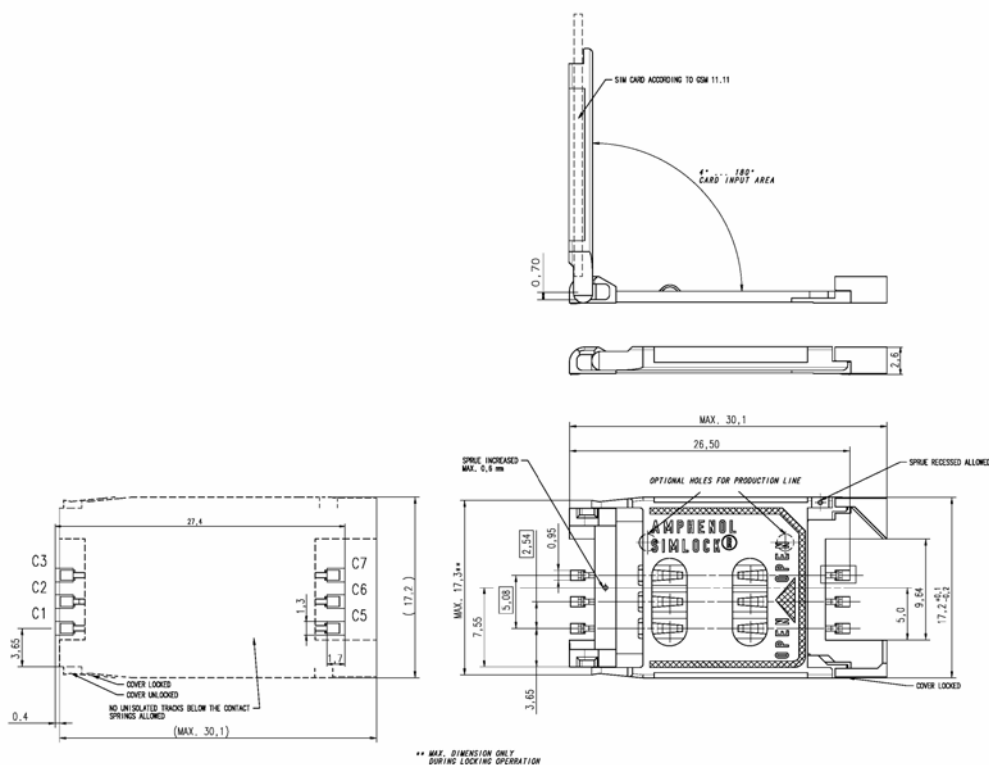

Figure 23: Amphenol C707 10M006 5122 UIM card holder

Table 18: Amphenol UIM socket pin description

Pin	Signal	Description
C1	UIM_VDD	UIM Card Power supply, it can identify automatically the UIM Card power mode, one is 3.0V±10%, another is 1.8V±10%.
C2	UIM_RST	UIM Card Reset.
C3	UIM_CLK	UIM Card Clock.
C5	GND	Connect to GND.
C6	VPP	NC
C7	UIM_DATA	UIM Card data I/O.

3.6 I2C Interface

I2C is used to communicate with peripheral equipments and can be operated as either a transmitter or receiver, depending on the device function. Use AT Commands "AT+CRIC" and "AT+CWIIC" to

read/write register values of related peripheral equipments connected with I2C interface.

3.6.1 Pin Description

Table 19: Pin description

Pin name	Pin No.	Function
SDA	56	Serial interface data input and output
SCL	55	Serial interface clock input

3.6.2 Signal Description

Both SDA and SCL are bidirectional lines, connected to a positive supply via a pull-up resistor respectively. When the bus is free, both lines are high.

3.6.3 Design Guide

For SIM6320x, the data on the I2C bus can be transferred at rates up to 400kbps. The number of peripheral devices connected to the bus is solely dependent on the bus capacitance limit of 400pF. Note that PCB traces length and bending are in customers' control to minimize load capacitance.

Note: SDA and SCL have been pulled up with two 2.2k resistors to 2.6V level in module. So there is no need to pull them up in customers' application circuit.

3.7 Keypad Interface

SIM6320x module provides a keypad interface that supports five sense lines, or columns, and five keypad rows. The interface generates an interrupt when any key is pressed. Its operation voltage is 2.6V.

3.7.1 Pin Description

Table 20: Pin description

Pin name	Pin No.	Function
KBC0	28	Sensed keypad line
KBC1	27	
KBC2	31	
KBC3	32	
KBC4	36	
KBR0	30	Driven keypad line
KBR1	29	
KBR2	30	
KBR3	35	
KBR4	34	

3.7.2 Application Guide

All keypad pins can be configured for GPIOs. These GPIOs also support interruption operation if used as input pins. A typical circuit about the keypad (5*5 keypad matrix) is shown in the following figure.

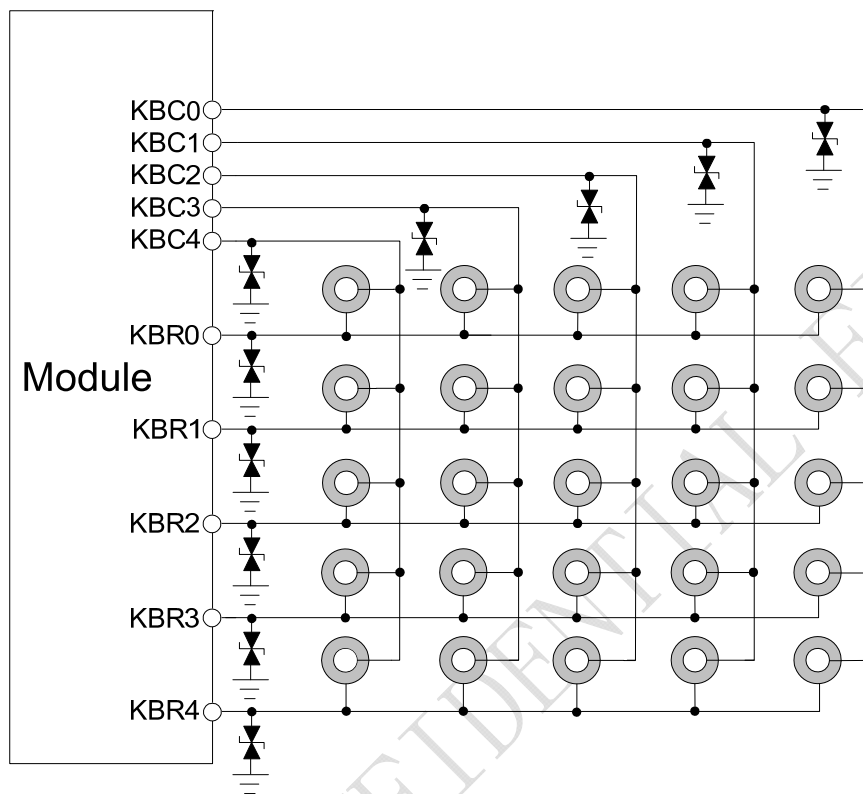

Figure 24: Reference circuit

If these pins are configured for GPIOs, the sequence is listed in the following table.

Table 21: Keypad Multiplexing Function

Pin name	Pin number	Mode 0(default)	Mode 1
KBR4	34	KBR4	GPIO6
KBR3	35	KBR3	GPIO7
KBR2	30	KBR2	GPIO8
KBR1	33	KBR1	GPIO9
KBR0	29	KBR0	GPIO10
KBC4	36	KBC4	GPIO11
KBC3	32	KBC3	GPIO12
KBC2	31	KBC2	GPIO13
KBC1	27	KBC1	GPIO14
KBC0	28	KBC0	GPIO15

3.8 USB Interface

SIM6320x module contains a USB interface. This interface is compliant with the USB2.0 specification. The USB2.0 specification requires hosts such as the computer to support USB full-speed (12Mbps), USB charging and USB-OTG is not supported.

Table 22: USB Pin Description

Pin name	Pin No.	Input voltage scope(V)		
		Min	Typ	Max
USB_VBUS	11	4.4	5.0	5.6
USB_DP	13	USB differential data I/O, (+) side		
USB_DN	12	USB differential data I/O, (-) side		

3.8.1 Application Guide

Currently SIM6320x supports the USB suspend and resume mechanism which can help to save power. If no transaction is on USB bus, SIM6320x will enter suspend mode. When some events such as voice call or receiving SMS happen, SIM6320x will resume normal mode automatically.

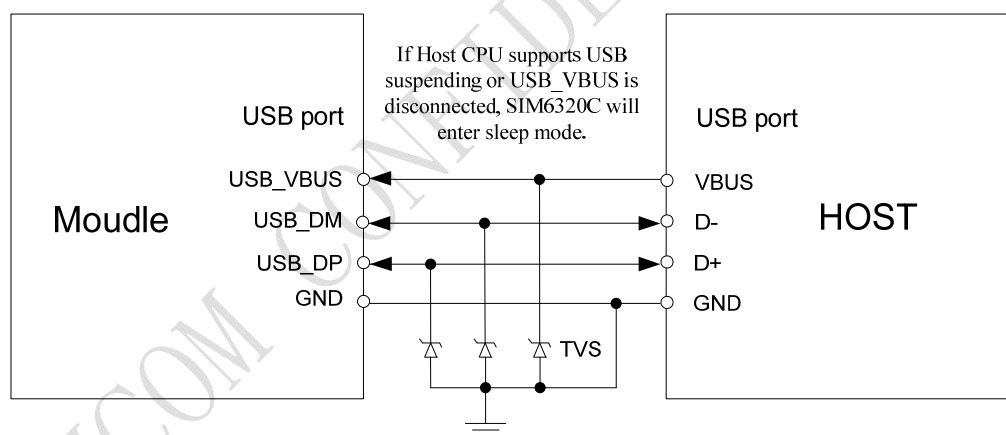

Figure 25: USB interface

Because of high bit rate on USB bus, customer needs to pay attention to influence of junction capacitance of ESD component on USB data lines. Typically, the capacitance should be less than 4pF @1MHz.

Note: The SIM6320x has two kinds of interface (UART and USB) to connect to host CPU. USB interface is mapped to five virtual ports: “SIMTECH USB Modem”, “SIMTECH NMEA Device”, “SIMTECH ATCOM Device”, “SIMTECH Diagnostics interface” and “SIMTECH Wireless Ethernet Adapter”.

3.9 SPI Interface

SPI interface of SIM6320x is master only. It provides a duplex, synchronous, serial communication link with peripheral devices. Its operation voltage is 1.8V, with clock rates up to 26 MHz.

3.9.1 Pin Description

Table 23: Pin Description

Pin name	Pin No.	Function
SPI_CS	9	SPI chip-select; not mandatory in a point-to-point connection
SPI_MISO	7	SPI master in/slave out data
SPI_CLK	6	SPI clock
SPI_MOSI	8	SPI master out/slave in data

Table 24: Electronic characteristic

Symbol	Parameter	Min	Typ	Max	Unit
V _{IH}	High-level input voltage	1.26	1.8	2.1	V
V _{IL}	Low-level input voltage	-0.3	0	0.63	V
V _{OH}	High-level output voltage	1.35	1.8	1.8	V
V _{OL}	Low-level output voltage	0	0	0.45	V

3.10 GPIO Interface

SIM6320x provides a limited number of GPIO pins. All GPIOs can be configured as inputs or outputs. Customer can use AT Commands to read or write GPIOs status. Refer to ATC document for details.

3.10.1 Pin Description

Table 25: Pin description

Pin name	Pin No.	I/O	Function
GPIO1	51	O	Output PIN as LED control for network status. If it is unused, left open.

GPIO4	54	I	Input PIN as RF operating control. H: Normal Mode L:Flight Mode If it is unused, left open.
GPIO40	49	O	Output PIN as operating status indicating of module. H: Power on L: Power off If it is unused, left open.
GPIO41	52	I/O	General input/output PIN. It can be used as wake/interrupt signal to host from module If it is unused, left open.
GPIO42	53	I/O	General Purpose Input/Output Port.
GPIO43	50	I/O	General Purpose Input/Output Port. It can be used as wake/interrupt signal to module from host. If it is unused, left open.
GPIO44	48	I/O	General Purpose Input/Output Port

Note: If more GPIOs need to be used, customers can configure GPIO on other multiple function interfaces, such as PCM. Please refer to GPIO list.

Table 26: GPIOs Electronic characteristic

Symbol	Parameter	Min	Typ	Max	Unit
V _{IH}	High-level input voltage	1.69	2.6	2.9	V
V _{IL}	Low-level input voltage	-0.3	-	0.91	V
V _{OH}	High-level output voltage	2.15	2.6	2.6	V
V _{OL}	Low-level output voltage	0	-	0.45	V

Note: The output driver current of GPIOs is 2mA.

3.10.2 Application Guide

Network status

GPIO1 is used to control Network Status LED; application circuit is shown below.

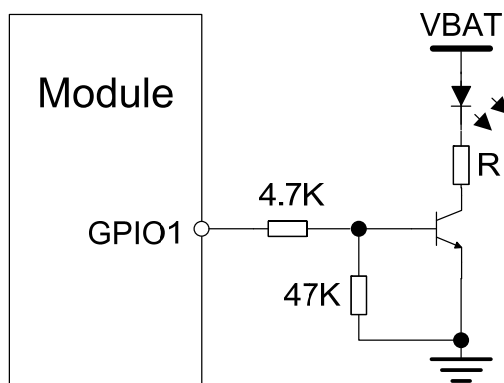

Figure 26: Application circuit

Note: The value of resistor R depends on LED characteristic.

Table 27: LED status

LED Status	Module Status
Always On	Searching Network/Call Connect
200ms ON, 200ms OFF	Data Transmit
800ms ON, 800ms OFF	Registered network
Off	Power off / Sleep

Flight mode control

GPIO4 controls SIM6320x module to enter or exit the Flight mode. In Flight mode, SIM6320x closes RF function to prevent interference with other equipments or minimize current consumption. Bidirectional ESD protection component is suggested to add on GPIO4.

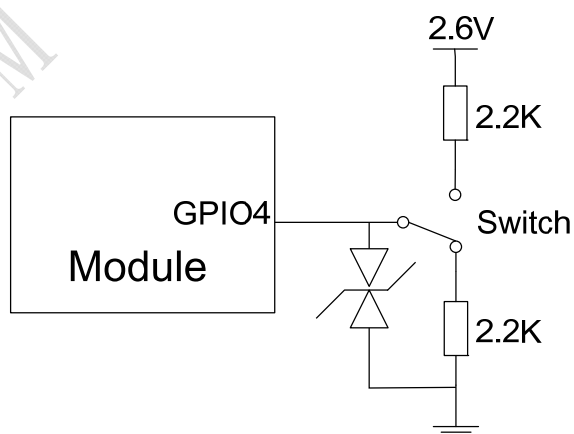

Figure 27: Flight mode switch

Table 28: Control status

GPIO4 Status	Module operation
Low Level	Flight Mode: RF is closed.
High Level	Normal Mode: RF is working.

Note: 1. For SIM6320x, GPIO0, GPIO2, GPIO3 and GPIO5 have multiplex function, customer can use them as PCM interface to connect extend codec. Refer to section 3.10 and document [1] for details.

2. When the module is powered off, make sure all digital interfaces (PCM UART, etc) connected with peripheral devices have no voltage higher than 0.3V. If customers' design cannot meet above conditions, high level voltages maybe occur in GPIO pins because current leakage from above digital interfaces may occur.

3.11 PCM Interface

SIM6320x provides hardware PCM interface for external codec. The PCM interface enables communication with an external codec to support hands-free applications. SIM6320x PCM interface can be used in two modes: the default mode is auxiliary PCM (8 kHz long sync mode at 128 kHz PCM CLK); the other mode is primary PCM (8 kHz short sync mode at 2048 kHz PCM CLK). In short-sync (primary PCM) mode, SIM6320x can be a master or a slave. In long-sync (auxiliary PCM) mode, SIM6320x is always a master. SIM6320x also supports 3 kinds of coding formats: 8 bits (μ-law or A-law) and 16 bits (linear).

Note: PCM interface is multiplexed from GPIO (default setting). The AT command "AT+CPCM" is used to switch between PCM and GPIO functions. Please refer to document [14] and document [1] for details.

3.11.1 Pin Description

Table 29: Pin description

Pins	Pin No.	Description
PCM_OUT	73	PCM data output
PCM_IN	74	PCM data input
PCM_SYNC	75	PCM data synchrony
PCM_CLK	76	PCM data clock

Table 30: Electronic characteristic

Symbol	Parameter	Min	Typ	Max	Unit
V _{IH}	High-level input voltage	1.69	2.6	2.9	V
V _{IL}	Low-level input voltage	-0.3	-	0.91	V
V _{OH}	High-level output voltage	2.15	2.6	2.6	V
V _{OL}	Low-level output voltage	0	-	0.45	V

3.11.2 Signal Description

The default PCM interface in SIM6320x is the auxiliary PCM interface. The data changes on the high level of PCM_CLK and is sampled at the falling edge of PCM_CLK in one period. Primary PCM is disabled after every power-on or every reset event. So customer must use AT command to enable the primary PCM mode after powering on or resetting the module every time if customer wants to use Primary PCM. SIM6320x PCM Interface can be operated in Master or Slave mode if it is configured to primary PCM. In Master Mode, the Module drives the clock and sync signals that are sent to the external codec. When it is in Slave Mode, the external codec drives the clock and sync signals which are sent to the module. Both PCM modes are discussed in this section followed by additional PCM topics.

Auxiliary PCM (128 kHz PCM clock)

-law coding is supported by the auxiliary PCM. The auxiliary codec port operates with standard long-sync timing and a 128 kHz clock. The AUX_PCM_SYNC runs at 8 kHz with 50% duty cycle. Most -law codec support the 128 kHz clock.

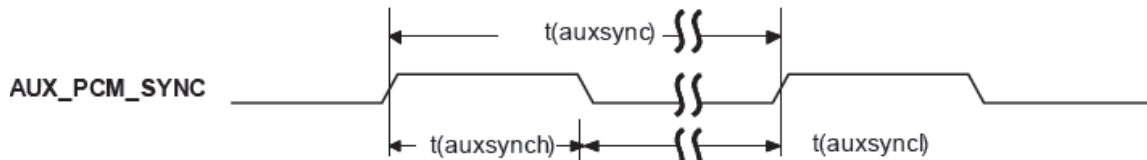

Figure 28: Synchrony timing

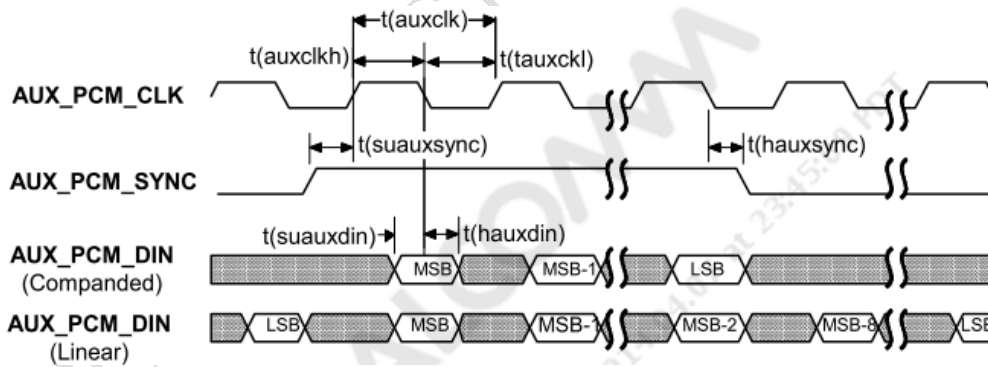

Figure 29: EXT CODEC to MODULE timing

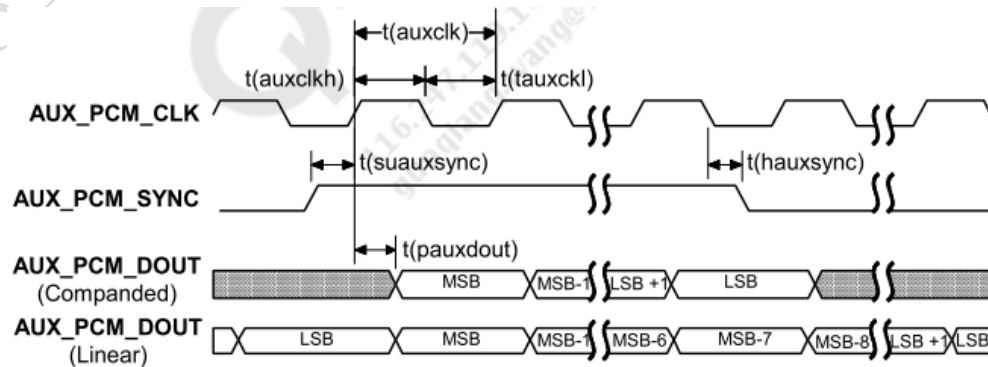

Figure 30: MODULE to EXT CODEC timing

Table 31: Timing parameters

Parameter	Description	Min	Typ	Max	Unit
T(auxsync)	AUX_PCM_SYNC cycle time	–	125	-	μs
T(auxsynch)	AUX_PCM_SYNC high time	62.4	62.5	-	μs
T(auxsyncl)	AUX_PCM_SYNC low time	62.4	62.5	-	μs
T(auxclk)*	AUX_PCM_CLK cycle time	-	7.8	–	μs
T(auxclkh)	AUX_PCM_CLK high time	3.8	3.9	–	μs
T(auxckl)	AUX_PCM_CLK low time	3.8	3.9	–	μs
T(suauxsync)	AUX_PCM_SYNC setup time high before falling edge of PCM_CLK	1.95	–	–	μs
T(hauxsync)	AUX_PCM_SYNC hold time after falling edge of PCM_CLK	1.95	–	–	μs
T(suauxdin)	AUX_PCM_IN setup time before falling edge of AUX_PCM_CLK	70	–	–	ns
T(hauxdin)	AUX_PCM_IN hold time after falling edge of AUX_PCM_CLK	20	–	–	ns
T(pauxdout)	Delay from AUX_PCM_CLK rising to AUX_PCM_OUT valid	–	–	50	ns

*Note: T(auxclk) = 1/(128 kHz).

Primary PCM (2048 kHz PCM clock)

SIM6320x also supports 2.048 MHz PCM data and sync timing for -law codec. This is called the primary PCM interface. Customer can use AT command to take the mode you want as discussed above.

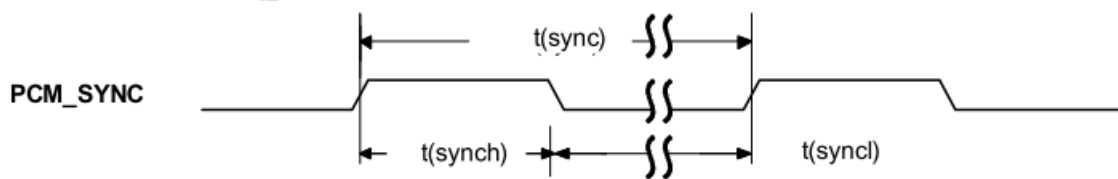

Figure 31: Synchrony timing

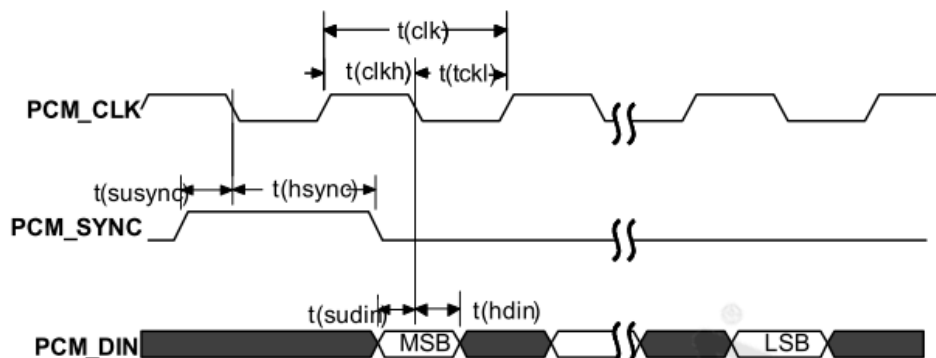

Figure 32: EXT CODEC to MODULE timing

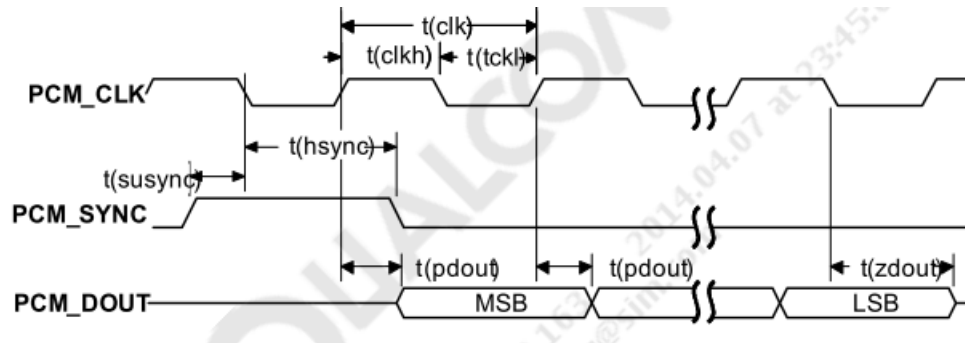

Figure 33: MODULE to EXT CODEC timing

Table 32: Timing parameters

Parameter	Description	Min	Typ	Max	Unit
T(sync)	PCM_SYNC cycle time	–	125	–	μs
T(synch)	PCM_SYNC high time	400	500	–	ns
T(syncnl)	PCM_SYNC low time	–	124.5	–	μs
T(clk)	PCM_CLK cycle time	–	488	–	ns
T(clkh)	PCM_CLK high time	–	244	–	ns
T(clkl)	PCM_CLK low time	–	244	–	ns
T(susync)	PCM_SYNC setup time high before falling edge of PCM_CLK	60	–	–	ns
T(hsync)	PCM_SYNC hold time after falling edge of PCM_CLK	60	–	–	ns
T(sudin)	PCM_IN setup time before falling edge of PCM_CLK	50	–	–	ns
T(hdin)	PCM_IN hold time after falling edge of PCM_CLK	10	–	–	ns
T(pdout)	Delay from PCM_CLK rising to PCM_OUT valid	–	–	350	ns
T(zdout)	Delay from PCM_CLK falling to PCM_OUT HIGH-Z	–	160	–	ns

Note: SIM6320x can transmit PCM data by USB except for PCM interface. *Please refer to document [14] for more information of PCM Application Note.*

3.11.3 PCM Multiplexing Function

Table 33: PCM multiplexing function

Pin name	Pin number	Mode 0(default)	Mode 1
PCM_CLK	76	PCM_CLK	GPIO3
PCM_OUT	73	PCM_OUT	GPIO5
PCM_SYNC	75	PCM_SYNC	GPIO2
PCM_IN	74	PCM_IN	GPIO0

3.12 Sink Current Source

The dedicated pin (ISINK) is intended for driving passive devices, such as LCD backlight, this implementation is +5V tolerant and suitable for driving white LEDs. The high-current driver can maintain a constant current which is set by the AT command “AT+ CLEDITST”, capable of up to 150 mA.

Table 34: Electronic characteristic

Symbol	Description	Min	Typ	Max	Unit
ISINK	Input voltage	0.5	VBAT	VBAT+0.5	V
I _O	Input current	-	-	150	mA

Since the driver is ground-referenced current sink, the operating device it drives must form a current path between the VDD pin and the ISINK pin. The following figure is for customers reference.

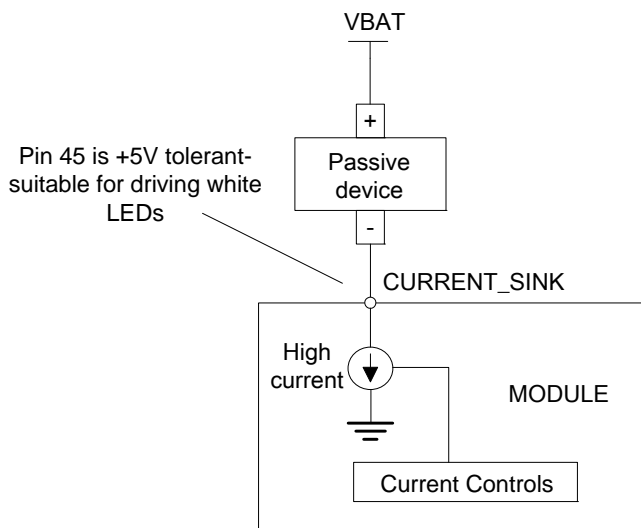

Figure 34: Current drive

3.13 Reset Function

SIM6320x also have a RESET pin (PIN4) to reset the module. This function is used as an emergency reset only when AT command “AT+CPOF” and the PWRKEY pin has no effect. Customer can pull the RESET pin to ground, then the module will reset.

This pin is already pulled up in module, so the external pull-up resistor is not necessary. A 100nF capacitor close to the RESET pin is strongly recommended. A reference circuit is recommended in the following figure.

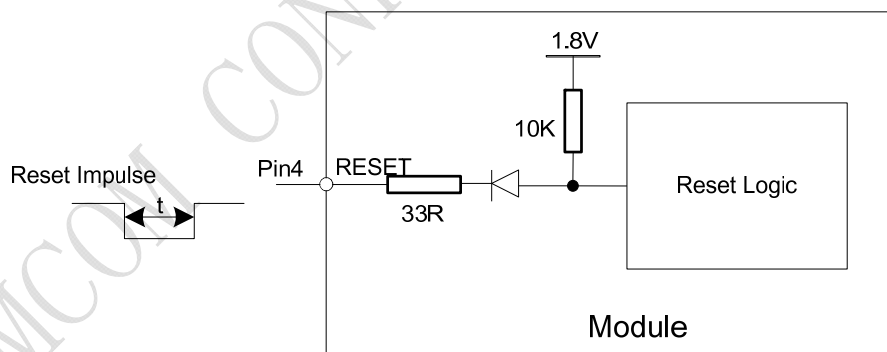

Figure 35: Reset circuit

Note: $50ms < t < 200ms$. ESD components are suggested to be used on Reset pin.

3.14 ADC

SIM6320x has a dedicated ADC that is available for digitizing analog signals such as battery voltage and so on; it is on PIN 47 and PIN 46 , namely ADC1 and ADC2 . This ADC is 12 bit successive-approximation circuit, and electronic specification is shown in the following table.

Table 35: Electronic Characteristics

Specification	Min	Typ	Max	Unit	Comments/Conditions
Resolution		12		Bits	
Differential nonlinearity	-1		+3	LSB	Analog Vdd = ADC reference 2.4MHz sample rate
Integral nonlinearity	-6		+6	LSB	
Full-Scale Error	-25.6		+25.6	LSB	
Offset Error	-12		+12	LSB	
Input Range	GND		2.5	V	47pin(ADC1)
	GND		2.1	V	46pin(ADC2)
Input serial resistance		1.5		kΩ	Sample and hold switch resistance
Input capacitance		12.4		pF	
Sampling time		9.6	9.2	μs	

Customer can introduce a analog signal in the ADC1 pin directly and use the AT command “AT+CADC” to get the raw data which is between 0 and 255. The data can be transformed to any type such as voltage, temperature etc.

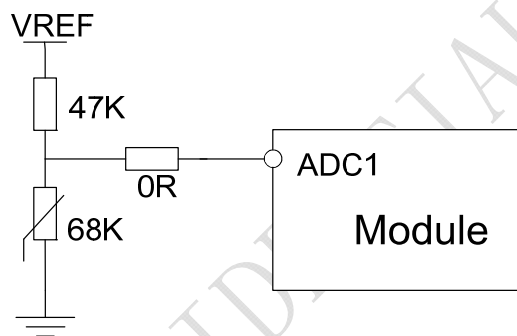

Figure 36: ADC1 Reference circuit

ADC2 allows monitoring of an analog signal from the battery module representing its temperature. The SIM6320x included a 10k pull-up resistor and 100-pF filter capacitor. Customer could use “AT+CADCA” to get value of ADC2.

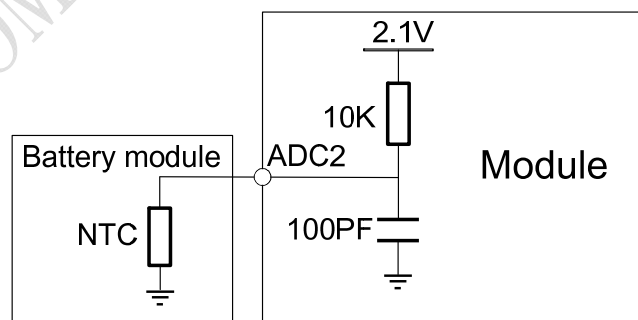

Figure 37: ADC2 Reference circuit

3.15 LDO

SIM6320x has a LDO power output, namely VDD_EXT. The LDO is available and output voltage is 2.6v by default, rated for 150mA. Customer can switch the LDO on or off by the AT command “AT+CVAUXS” and configure its output voltage by the AT command “AT+CVAUXV”.

Table 36: Electronic characteristic

Symbol	Description	Min	Typ	Max	Unit
VDD_EXT	Output voltage	1.5	2.6	3.05	V
I _o	Output current	-	-	150	mA

3.16 GPS (Only SIM6320)

SIM6320x merges GPS satellite and network information to provide a high-availability solution that offers industry-leading accuracy and performance. This solution performs well, even in very challenging environmental conditions where conventional GPS receivers fail, and provides a platform to enable wireless operators to address both location-based services and emergency mandates.

3.16.1 Technical specification

Tracking sensitivity	-159 dBm
Cold-start sensitivity	-148 dBm
Accuracy (Open Sky)	2.5m (CEP50)
TTFF (Open Sky)	Hot start <1s Cold start 35s
Receiver Type	16-channel, C/A Code GPS L1 Frequency (1575.42±1.023MHz),
Update rate	Default 1 Hz
GPS data format	NMEA-0183
GPS Current consumption (CDMA Sleep mode)	100mA (Total supply current)
GPS antenna	Passive/Active antenna

Note: Performance will vary depending on the environment, antenna type and signal conditions and so on.

3.16.2 Operate Mode

SIM6320x supports both A-GPS and S-GPS, and then provides three operating modes: mobile-assisted mode, mobile-based mode and standalone mode. A-GPS includes mobile-assisted and mobile-based mode.

In mobile-assisted mode, when a request for position location is issued, available network information is provided to the location server (e.g. Cell-ID) and assistance is requested from the location server. The location server sends the assistance information to the handset. The handset/mobile unit measures the GPS observables and provides the GPS measurements along with available network data (that is appropriate for

the given air interface technology) to the location server. The location server then calculates the position location and returns results to the requesting entity.

In mobile-based mode, the assistant data provided by the location server encompasses not only the information required to assist the handset in measuring the satellite signals, but also the information required to calculate the handset's position. Therefore, rather than provide the GPS measurements and available network data back to the location server, the mobile calculates the location on the handset and passes the result to the requesting entity.

In standalone (autonomous) mode, the handset demodulates the data directly from the GPS satellites. This mode has some reduced cold-start sensitivity, and a longer time to first fix as compared to the assisted modes. However, it requires no server interaction and works out of network coverage.

This combination of GPS measurements and available network information provides:

- High-sensitivity solution that works in all terrains: Indoor, outdoor, urban, and rural
- High availability that is enabled by using both satellite and network information
- Therefore, while network solutions typically perform poorly in rural areas and areas of poor cell geometry/density, and while unassisted, GPS-only solutions typically perform poorly indoors. The SIM6320X GPS solution provides optimal time to fix, accuracy, sensitivity, availability, and reduced network utilization in both of these environments, depending on the given condition.

3.16.3 Application Guide

SIM6320 have an integrated Low-Noise Amplifier (LNA), the total gain of GPS antenna and integrated LNA should be less than 17dB required by the GPS receiver, otherwise, overlarge gain will degrade the GPS performance. For gain of integrated LNA is 16.5dB, passive antenna is recommended. In weak GPS situation, active antenna is optional, but the strength of GPS signal should not exceed the input range of GPS receiver, user can get the strength of GPS signal by AT command AT+CGPSINFO, AmpI and AmpQ value should be less than 500.

In this document, all GPS specification mentioned is from passive antenna. The following is the reference circuit.

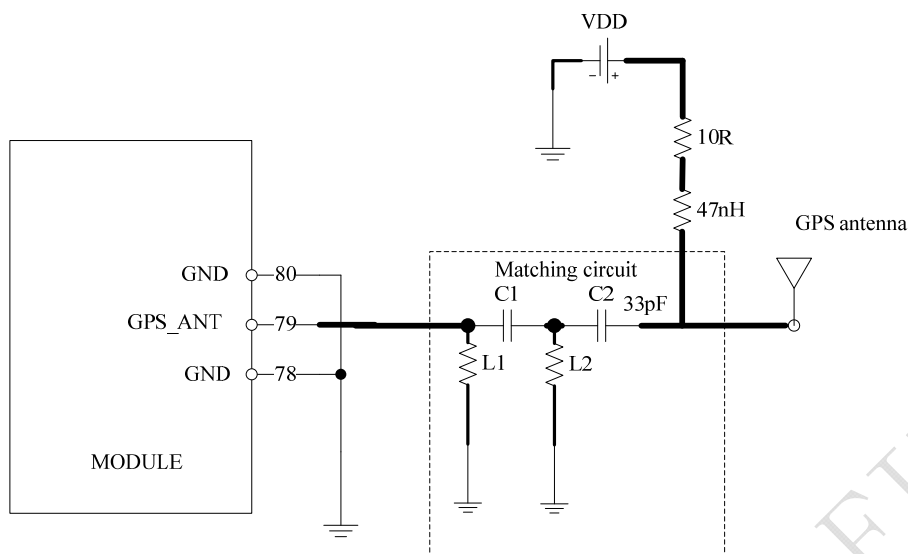

Figure 38: Active antenna circuit

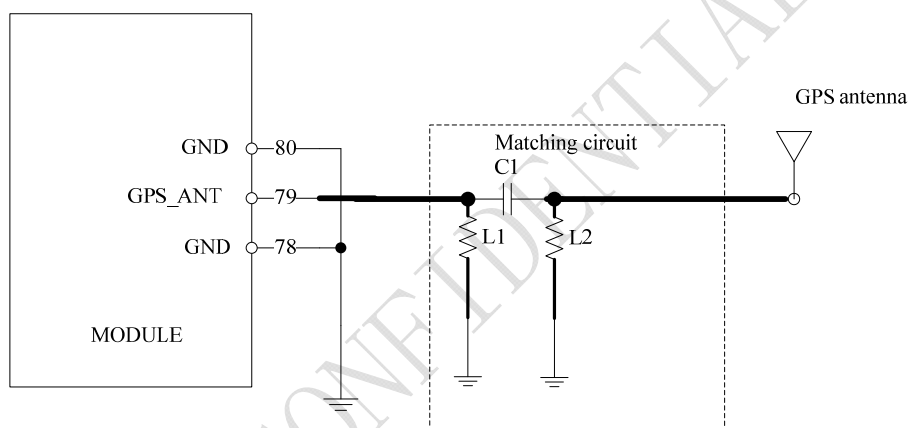

Figure 39: Passive antenna circuit (Default)

In above figures, the components C1 and L1, L2 are used for antenna matching, the values of the components can only be obtained after the antenna tuning usually, and they are provided by antenna vendor. C2 in Figure 35 is used for DC isolation. In active antenna circuit, users must use an external LDO/DCDC to provide VDD voltage whose value should be taken according active antenna characteristic, and VDD can be shut down to avoid consuming additional current when not being used.

GPS can be used by NMEA port. User can select NMEA as output through UART or USB. NMEA sentences are automatic and no command is provided. NMEA sentences include GSV, GGA, RMC, GSA, and VTG. Before using GPS, user should configure SIM6320x in proper operating mode by AT command. Please refer to related document for details. SIM6320x can also get position location information through AT directly.

Note: GPS is closed by default, it could be started by AT+CGPS. The AT command has two parameters, the first is on/off, and the second is GPS mode. Default mode is standalone mode.

AGPS mode needs more support from the mobile telecommunication network. Refer to AGPS application document for details.

4 RF Specification

4.1 RF Specification

Table 37: Conducted transmission power

Frequency	Max	Min
CDMA 800MHZ	23~30dBm	< -50dBm

Table 38: Operating frequencies

Frequency	Receiving	Transmission
CDMA 800MHZ	869~894MHz	824~849MHz

Table 39: Conducted receive sensitivity

Frequency	Receive sensitivity (Typical)	Receive sensitivity(Max)
CDMA 800MHZ	-108dBm	-106dBm

4.2 Antenna Design Guide

SIM6320x provides RF antenna interface. Customer's antenna should be located in the host board and connected to module's antenna pad through micro-strip line or other types of RF trace and the trace impedance must be controlled in 50Ω. SIMCom recommends that the total insertion loss between the antenna pad and antenna should meet the following requirements:

- CDMA 800MHZ<0.5dB

To facilitate the antenna tuning and certification test, a RF connector and an antenna matching circuit should be added. The following figure is the recommended circuit.

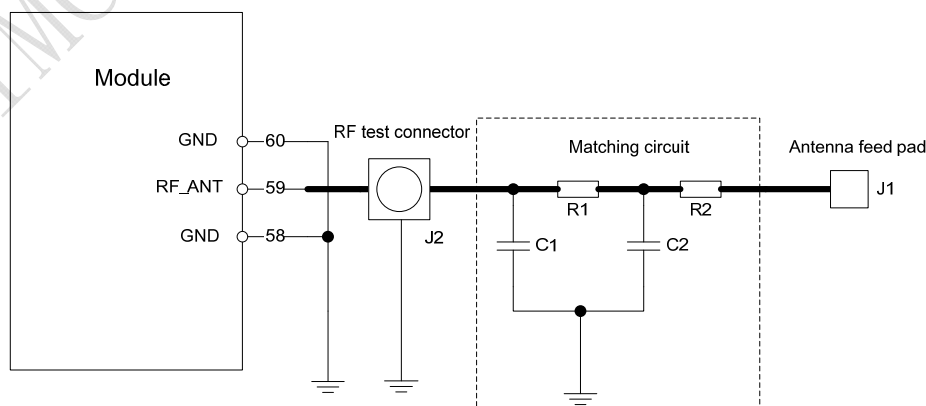

Figure 40: Antenna matching circuit

In this figure, the components R1,C1,C2 and R2 is used for antenna matching, the value of components can only be got after the antenna tuning, usually, they are provided by antenna vendor. By default, the R1, R2 are 0 ohm resistors, and the C1, C2 are reserved for tuning.

The RF test connector in the figure is used for the conducted RF performance test, and should be placed as close as to the module's antenna pin. The traces impedance between components must be controlled in 50ohm.

SIMCOM CONFIDENTIAL FILE

5 Reliability and Operating Characteristics

5.1 Electronic Characteristics

Absolute maximum rating for digital and analog pins of SIM6320x are listed in the following table:

Table 40: Absolute maximum ratings

Symbol	Parameter	Min	Typ	Max	Unit
VDD_EXT	Voltage For Camera/SDCC	-0.3	-	3.15	V
VBAT_BB	Voltage at VBAT_BB	-0.5	-	5.0	V
VBAT_RF	Voltage at VBAT_RF	0	-	5.0	V
USB_VBUS	Voltage at USB_VBUS	-0.5	-	7.5	V

Table 41: Recommended operating conditions

Symbol	Parameter	Min	Typ	Max	Unit
VDD_EXT	Voltage For Camera/SDCC	1.5	2.6	3.05	V
VBAT_BB	Voltage at VBAT_BB	3.3	3.8	4.2	V
VBAT_RF	Voltage at VBAT_RF	3.3	3.8	4.2	V
VRTC	Voltage at VRTC	1.5	3.0	3.25	V
USB_VBUS	Voltage at USB_VBUS	4.4	5	5.6	V

The operating temperature and power specification is listed in the following table.

Table 42: Operating temperature

Symbol	Parameter	Min	Typ	Max	Unit
T _O	Normal operation temperature (ambient)[1]	-30	+25	+80	°C
T _R	Restricted operation temperature (ambient)[2]	+80		+85	°C
		-30		-40	°C
T _{STG}	Storage temperature	-40	+25	+90	°C

Note:

[1]: When the SIM6320x module works at this temperature, all its RF indexes comply with the ETSI specifications

[2]: When the SIM6320x module works at this temperature, may be NOT all its RF indexes comply with the ETSI specifications

Table 43: Digital I/O characteristics

Parameter	Description	2.6V Digital I/O			1.8V Digital I/O			Unit
		Min	Typ	Max	Min	Typ	Max	
V _{IH}	High-level input voltage	1.69	2.6	2.9	1.26	1.8	2.1	V
V _{IL}	Low-level input voltage	-0.3	0	0.91	-0.3	0	0.63	V
V _{OH}	High-level output voltage	2.15	2.6	2.6	1.35	1.8	1.8	V
V _{OL}	Low-level output voltage	0	0	0.45	0	0	0.45	V
I _{OH}	High-level output current	-	2	-	-	1	-	mA
I _{OL}	Low-level output current	-	-2	-	-	-1	-	mA
I _{IH}	Input high leakage current	-	-	1	-	-	1	uA
I _{IL}	Input low leakage current	-1	-	-	-1	-	-	uA
C _{IN}	Input capacitance	-	-	7	-	-	7	pF

Note: These parameters are for digital interface pins, such as keypad, GPIO, I²C, UART, SPI. Digital I/O specifications under both conditions are presented in the above tables.

SPI are 1.8v Digital I/O voltage.

GPIO, I2C ,keypad and UART are 2.6v Digital I/O voltage.

5.2 Operating Mode

The table below summarizes the various operating modes of SIM6320x.

5.2.1 Operating Modes Overview

Table 44: Overview of operating modes

Mode	Function	
Normal operation	CDMA2000 SLEEP	Module will automatically go into sleep mode if the conditions of sleep mode are enabled and there is no on air and no hardware interrupt (such as GPIO interrupt or data on serial/USB port). In this case, the current consumption of module will be reduced to the minimal level. In sleep mode, the module can still receive paging message and SMS.
	CDMA2000 IDLE	Software is active. Module is registered to the CDMA network, and module is ready to communicate.
	CDMA2000 TALK	Connection between two subscribers is in progress. In this case, the power consumption depends on network settings
	EV-DO rev. A TRANSFER DATA	There is EVDO data transfer in progress. In this case, power consumption is related with network settings (e.g. power control level); uplink/downlink data rates.
Power down		Normal power down by sending the AT command “AT+CPOF” or using the PWRKEY. The power management unit shuts down the power supply for the baseband part of the module, and only the power supply for the RTC is remained. Software is not active. The serial port and USB are not accessible. Power supply (connected to VBAT) remains applied.
Minimum functionality mode		AT command “AT+CFUN” can be used to set the module to a minimum functionality mode without removing the power supply. In this mode, the RF part of the module will not work or the UIM card will not be accessible, or both RF part and UIM card will be closed, and the serial port and USB are still accessible. The power consumption in this mode is lower than normal mode.

5.2.2 Minimize Power Consumption

There are two modes that SIM6320x achieves low power consumption.

Sleep mode

If peripheral equipments stops working, and there is no on air or hardware interrupts (such as GPIO interrupts or data on UART), SIM6320x will enter sleep mode automatically. In this mode, SIM6320x can still receive paging, voice call or SMS from network. If USB interface of SIM6320x is connected to host CPU, but host CPU does not support USB suspending, then SIM6320x will not enter sleep mode. After USB is disconnected, SIM6320x will enter sleep mode.

Note: When UART interface is connected with host CPU, SIM6320x can not enter sleep mode until RXD is pulled down by the host CPU. If the module is in the idle mode, make sure to pull the RXD to

low level by host CPU. SIMCom recommends using GPIO43 or DTR to wake up the module from host CPU and to use GPIO41 or RI to wake up the host CPU. Before designing, pay attention to how to realize waking function and refer to Document[17] and Document[18] for more detail.

Minimum functionality mode

Minimum functionality mode ceases a majority function of module, thus minimizing the power consumption. This mode is set by the AT command which provides a choice of the functionality levels.

- AT+CFUN=0: Minimum functionality
- AT+CFUN=1: Full functionality (Default)
- AT+CFUN=4: Disable RF function of the module (Flight mode)

If SIM6320x has been set to minimum functionality mode, the module will firstly enter sleep mode, then the RF function and UIM card function will be closed. In this case, the serial port is still accessible, but all AT commands correlative with RF function and UIM card function will not be accessible. When SIM6320x is in minimum functionality or flight mode, it can return to full functionality by the AT command “AT+CFUN=1”.

5.3 EMC and ESD Notes

EMC tests should be performed to detect any potential problems. Possible harmful emissions radiate by the application to the RF receiver in the receiver band. RF emissions interfere with audio input/output. It is recommended to shield the sensitive components and trace with common ground and customer can add beads where necessary.

Normally SIM6320x is mounted on customer host board. Although some ESD components have been added in SIM6320x, to prevent ESD, customer should put some ESD components on customers' board. The ESD components should be placed beside the connectors which human body might touch, such as SIM card holder, audio jacks, switches, keys, etc. The following table is the SIM6320x ESD measurement performance; the results are from SIMCom EVB test.

Table 45: The ESD performance measurement table (Temperature: 25°C, Humidity: 45%)

Part	Contact discharge	Air discharge
VBAT_BB,VBAT_RF,GND	±4KV	±8KV
UART,USB	±2KV	±6KV
Antenna port	±4KV	±6KV
Other ports	±2KV	±2KV

5.4 Current Consumption

The current consumption in suspended mode and without USB connection is listed in the table below. Here, “suspended mode” means that SIM6320x is connected to USB bus, but it does not transfer data.

Table 46: Current consumption(VBAT=3.8V)

Symbol	Parameter	Conditions	Value	Unit		
I _{VRTC}	VRTC current	VBAT disconnects. Backup battery is 3 V	1	uA		
I _{VBAT}	VBAT current	Power down mode	17.5	uA		
		Sleep mode (CDMA2000- China Telecom)	AT+CFUN=0	0.49	mA	
			AT+CFUN=1	2.24		
			AT+CFUN=4	0.59		
		Sleep mode (CMU)	Cellular 800M	2.8	mA	
		Voice call (CMU)	Cellular 800M MAX POWER	CH=283	493.4	mA
				CH=384	478.2	
				CH=799	530.5	
			Cellular 800M CDMA POWER-60dBm	CH=283	154.3	mA
				CH=384	158.9	
				CH=799	161.3	
			Cellular 800M MIN POWER	CH=283	147.5	mA
				CH=384	153.4	
				CH=799	152.6	
		Voice call (CDMA2000- China Telecom)	Cellular 800M	142.45	mA	
Idle	CMU (with USB)	39.5	mA			
	CMU (without USB)	38.7	mA			

6 Guide for Production

6.1 Top and Bottom View of SIM6320x



Figure 41: Top and bottom view of SIM6320x

These test points are only used for module manufacturing and testing. They are not for customer's application.

6.2 Typical Solder Reflow Profile

For customer convenience, SIMCom provides a typical example for a commonly used soldering profile. In final board assembly, the typical solder reflow profile will be determined by the largest component on the board, as well as the type of solder/flux used and PCB stack-up. Therefore the soldering profile shown below is only a generic recommendation and should be adjusted to the specific application and manufacturing constraints.

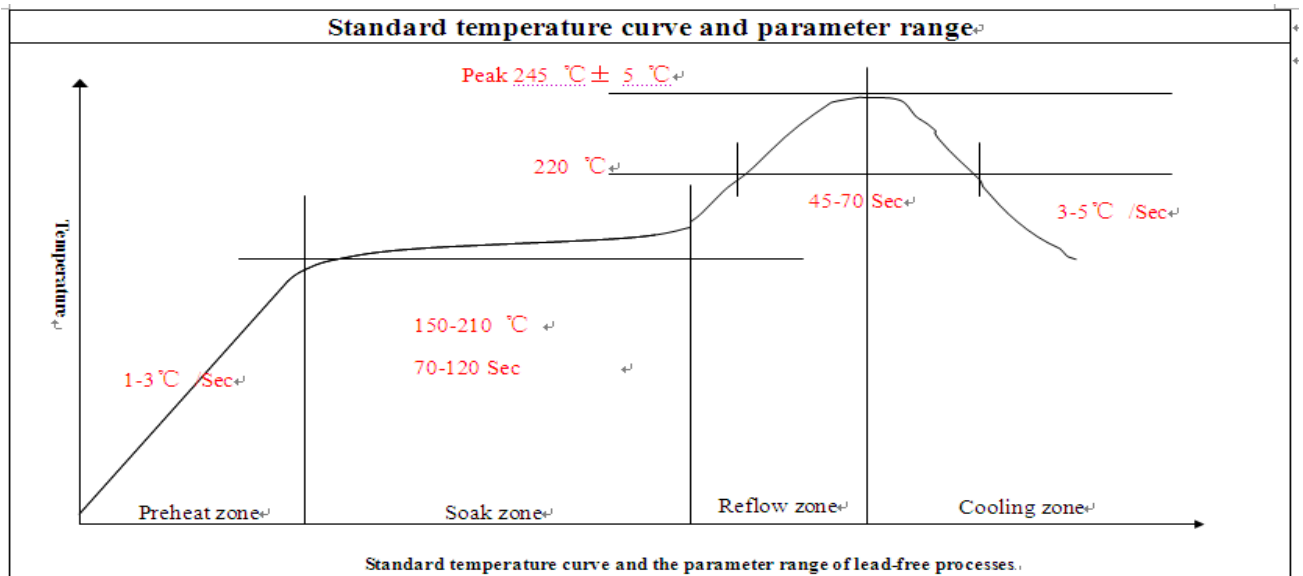

Figure 422: The ramp-soak-spike reflow profile of SIM6320x

For details about secondary SMT, please refer to *document [19]*.

6.3 Moisture Sensitivity Level (MSL)

SIM6320x is qualified to Moisture Sensitivity Level (MSL) 5 in accordance with JEDEC J-STD-020. After the prescribed time limit exceeded, customers should bake modules for 192 hours in drying equipment (<5% RH) at 40° C +5° C/-0° C, or 72 hours at 85° C +5° C/-5° C. Note that plastic tray is not heat-resistant, customers must not use the tray to bake at 85° C or the tray may be damaged.

Table 47: Moisture sensitivity level and floor life

Moisture Sensitivity Level (MSL)	Floor Life (out of bag) at factory ambient ≤30° C/60% RH or as stated
1	Unlimited at ≅ 30°C/85% RH
2	1 year
2a	4 weeks
3	168 hours
4	72 hours
5	48 hours
5a	24 hours
6	Mandatory bake before use. After bake, it must be reflowed within the time limit specified on the label.

6.4 Stencil Foil Design Recommendation

The recommended thickness of stencil foil is more than 0.15mm.

Appendix

A. System Design

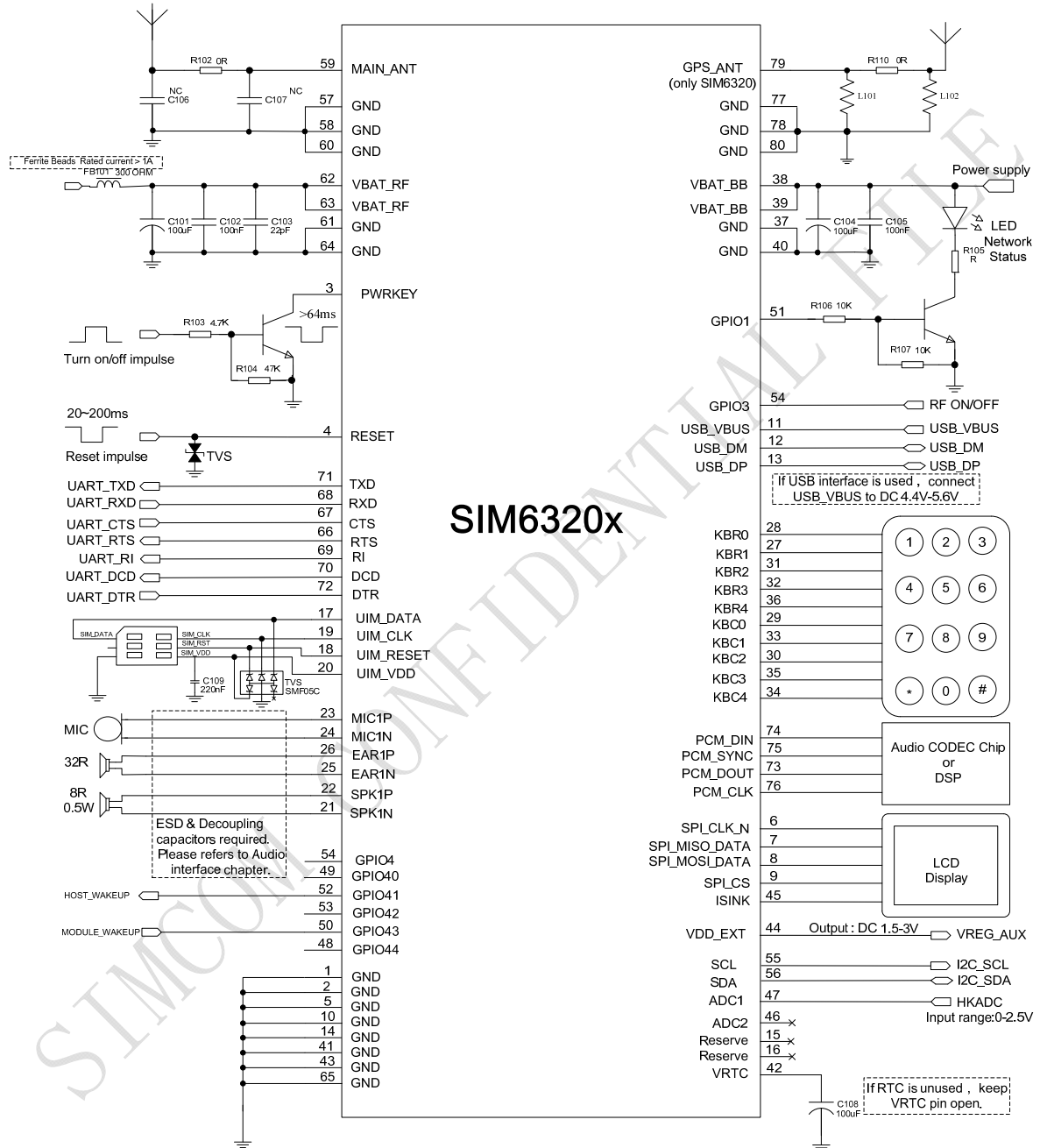

Figure 43: System design

B. SIM6320x GPIOs List

Table 48: SIM6320x GPIOs list

Name	PIN Number	GPIO Index	Default Function	Alternate Function
PCM_IN	74	0	GPIO Interrupt [LEVEL/LOW]	PCM_IN
GPIO1	51	1	Status led	GPIO
PCM_SYNC	75	2	GPIO [IN]	PCM_SYNC
PCM_CLK	76	3	GPIO [OUT/LOW]	PCM_CLK
GPIO4	54	4	RF Switch	Enable/Disable RF subsystem
PCM_OUT	73	5	GPIO [OUT/LOW]	PCM_OUT
KBR4	34	6	Keypad	GPIO
KBR3	35	7	Keypad	GPIO
KBR2	30	8	Keypad	GPIO
KBR1	33	9	Keypad	GPIO
KBR0	29	10	Keypad	GPIO
KBC4	36	11	Keypad	GPIO
KBC3	32	12	Keypad	GPIO
KBC2	31	13	Keypad	GPIO
KBC1	27	14	Keypad	GPIO
KBC0	28	15	Keypad	GPIO
CTS	67	33	CTS	GPIO
RTS	66	34	RTS	GPIO
DTR	72	35	DTR wake up module	GPIO
DCD	70	36	DCD	GPIO
RI	69	37	RI wake up host	GPIO
GPIO40	49	40	Module power up status	GPIO
GPIO41	52	41	Wake up host	GPIO
GPIO42	53	42	GPIO[OUT/LOW]	GPIO
GPIO43	50	43	Wake up module	GPIO
GPIO44	48	44	GPIO[OUT/LOW]	GPIO

C. Terms and Abbreviations

Table 49: Terms and Abbreviations

Abbreviation	Description
ADC	Analog-to-Digital Converter
ARP	Antenna Reference Point
BER	Bit Error Rate
BTS	Base Transceiver Station
CS	Coding Scheme
CSD	Circuit Switched Data
CTS	Clear to Send
DAC	Digital-to-Analog Converter
DRX	Discontinuous Reception
DSP	Digital Signal Processor
DTE	Data Terminal Equipment (typically computer, terminal, printer)
DTR	Data Terminal Ready
DTX	Discontinuous Transmission
EFR	Enhanced Full Rate
EGSM	Enhanced GSM
EMC	Electromagnetic Compatibility
ESD	Electrostatic Discharge
ETS	European Telecommunication Standard
FCC	Federal Communications Commission (U.S.)
FD	SIM fix dialing phonebook
FDMA	Frequency Division Multiple Access
FR	Full Rate
GMSK	Gaussian Minimum Shift Keying
GPRS	General Packet Radio Service
GSM	Global Standard for Mobile Communications
HR	Half Rate
I2C	Inter-Integrated Circuit
IMEI	International Mobile Equipment Identity
Inorm	Normal Current
Imax	Maximum Load Current
kbps	Kilo bits per second
Li-Ion	Lithium-Ion
MO	Mobile Originated
MS	Mobile Station (GSM engine), also referred to as TE
MT	Mobile Terminated
PAP	Password Authentication Protocol
PBCCH	Packet Switched Broadcast Control Channel
PCB	Printed Circuit Board
PCS	Personal Communication System, also referred to as GSM 1900
RF	Radio Frequency

RMS	Root Mean Square (value)
RTC	Real Time Clock
Rx	Receive Direction
SIM	Subscriber Identification Module
SMS	Short Message Service
SPI	serial peripheral interface
TDMA	Time Division Multiple Access
TE	Terminal Equipment, also referred to as DTE
TX	Transmit Direction
UART	Universal Asynchronous Receiver & Transmitter
VSWR	Voltage Standing Wave Ratio
Vmax	Maximum Voltage Value
Vnorm	Normal Voltage Value
Vmin	Minimum Voltage Value
VIHmax	Maximum Input High Level Voltage Value
VIHmin	Minimum Input High Level Voltage Value
VILmax	Maximum Input Low Level Voltage Value
VILmin	Minimum Input Low Level Voltage Value
VImax	Absolute Maximum Input Voltage Value
Vimin	Absolute Minimum Input Voltage Value
VOHmax	Maximum Output High Level Voltage Value
VOHmin	Minimum Output High Level Voltage Value
VOLmax	Maximum Output Low Level Voltage Value
VOLmin	Minimum Output Low Level Voltage Value
SM	SIM phonebook
NC	Not connect
EDGE	Enhanced data rates for GSM evolution
HSDPA	High Speed Downlink Packet Access
HSUPA	High Speed Uplink Packet Access
ZIF	Zero intermediate frequency
WCDMA	Wideband Code Division Multiple Access
VCTCXO	Voltage control temperature-compensated crystal oscillator
UIM	Universal subscriber identity module
UMTS	Universal mobile telecommunications system
UART	Universal asynchronous receiver transmitter

D. Related Documents







Table 50: Related documents

SN	Document name	Remark
[1]	SIM6320_ATC_V1.xx	SIM6320_ATC_V1.xx
[2]	ITU-T Draft new recommendation V.25ter	Serial asynchronous automatic dialing and control
[3]	3GPP TS 51.010-1	Digital cellular telecommunications system (Release 5); Mobile Station (MS) conformance specification
[4]	3GPP TS 34.124	Electromagnetic Compatibility (EMC) for mobile terminals and ancillary equipment.
[5]	3GPP TS 34.121	Electromagnetic Compatibility (EMC) for mobile terminals and ancillary equipment.
[6]	3GPP TS 34.123-1	Technical Specification Group Radio Access Network; Terminal conformance specification; Radio transmission and reception (FDD)
[7]	3GPP TS 34.123-3	User Equipment (UE) conformance specification; Part 3: Abstract Test Suites.
[8]	EN 301 908-02 V2.2.1	Electromagnetic compatibility and Radio spectrum Matters (ERM); Base Stations (BS) and User Equipment (UE) for IMT-2000. Third Generation cellular networks; Part 2: Harmonized EN for IMT-2000, CDMA Direct Spread (UTRA FDD) (UE) covering essential requirements of article 3.2 of the R&TTE Directive
[9]	EN 301 489-24 V1.2.1	Electromagnetic compatibility and Radio Spectrum Matters (ERM); Electromagnetic Compatibility (EMC) standard for radio equipment and services; Part 24: Specific conditions for IMT-2000 CDMA Direct Spread (UTRA) for Mobile and portable (UE) radio and ancillary equipment
[10]	IEC/EN60950-1(2001)	Safety of information technology equipment (2000)
[11]	3GPP TS 51.010-1	Digital cellular telecommunications system (Release 5); Mobile Station (MS) conformance specification
[12]	GCF-CC V3.23.1	Global Certification Forum - Certification Criteria
[13]	2002/95/EC	Directive of the European Parliament and of the Council of 27 January 2003 on the restriction of the use of certain hazardous substances in electrical and electronic equipment (RoHS)
[14]	Audio Application Note V1.01	Audio Application Note V1.01
[15]	Reserved	Reserved
[16]	Keypad Application Note V1.01	Keypad Application Note V1.01
[17]	<i>Sleep_Application_Note</i>	<i>Sleep_Application_Note</i>
[18]	<i>Waking_up_Application_Note</i>	<i>Waking_up_Application_Note</i>
[19]	Module secondary-SMT-UGD	SMT Note
[20]	SIM5xxx_Automatic_P	SIM5xxx_Automatic_POWER_ON_Application_Note

OWER_ON_Applicati
on_Note

E. Safety Caution

Table 51: Safety caution

Marks	Requirements
	When in a hospital or other health care facility, observe the restrictions about the use of mobiles. Switch the cellular terminal or mobile off, medical equipment may be sensitive to not operate normally for RF energy interference.
	Switch off the cellular terminal or mobile before boarding an aircraft. Make sure it is switched off. The operation of wireless appliances in an aircraft is forbidden to prevent interference with communication systems. Forget to think much of these instructions may lead to the flight safety or offend against local legal action, or both.
	Do not operate the cellular terminal or mobile in the presence of flammable gases or fumes. Switch off the cellular terminal when you are near petrol stations, fuel depots, chemical plants or where blasting operations are in progress. Operation of any electrical equipment in potentially explosive atmospheres can constitute a safety hazard.
	Your cellular terminal or mobile receives and transmits radio frequency energy while switched on. RF interference can occur if it is used close to TV sets, radios, computers or other electric equipment.
	Road safety comes first! Do not use a hand-held cellular terminal or mobile when driving a vehicle, unless it is securely mounted in a holder for hands free operation. Before making a call with a hand-held terminal or mobile, park the vehicle.
	<p>GSM cellular terminals or mobiles operate over radio frequency signals and cellular networks and cannot be guaranteed to connect in all conditions, for example no mobile fee or a invalid SIM card. While you are in this condition and need emergent help, please remember using emergency calls. In order to make or receive calls, the cellular terminal or mobile must be switched on and in a service area with adequate cellular signal strength.</p> <p>Some networks do not allow for emergency call if certain network services or phone features are in use (e.g. lock functions, fixed dialing etc.). You may have to deactivate those features before you can make an emergency call.</p> <p>Also, some networks require that a valid SIM card be properly inserted in the cellular terminal or mobile.</p>

Contact us:

Shanghai SIMCom Wireless Solutions Ltd.

Add: SIM Technology Building, No.633, Jinzhong Road, Changning District, Shanghai P.R.
China 200335

Tel: +86 21 3235 3300

Fax: +86 21 3235 3301

URL: www.sim.com/wm

SIMCOM CONFIDENTIAL FILE