



## Compact Two-way Operation Type SPVS Series

Poles		1
Positions		1
Terminal type		For PC board (Reflow)
Operating force		0.35N max.
Lever length		Standard
Operating direction		Left
Circuit		N/C
Location lug		Without
Frame leg		With
Operating temperature range		-40°C to +85°C
Rating (max.)/(min.) (Resistive load)		1mA 5V DC/50μA 3V DC
Electrical performance	Contact resistance (Initial/After operating life)	2Ω max./5Ω max.
	Insulation resistance	100MΩ min. 100V DC
	Voltage proof	100V AC for 1 minute
Mechanical performance	Terminal strength	0.5N for 1 minute
	Actuator strength	5N
Durability	Operating life without load	50,000 cycles 5Ω max.
	Operating life with load Rating (max.) (Resistive load)	50,000 cycles 5Ω max.
Environmental	Cold	-40°C 96h

performance	Dry heat	85°C 96h
	Damp heat	40°C, 90 to 95%RH 96h
Minimum order unit (pcs.)	Japan	5,000
	Export	20,000

## Dimensions

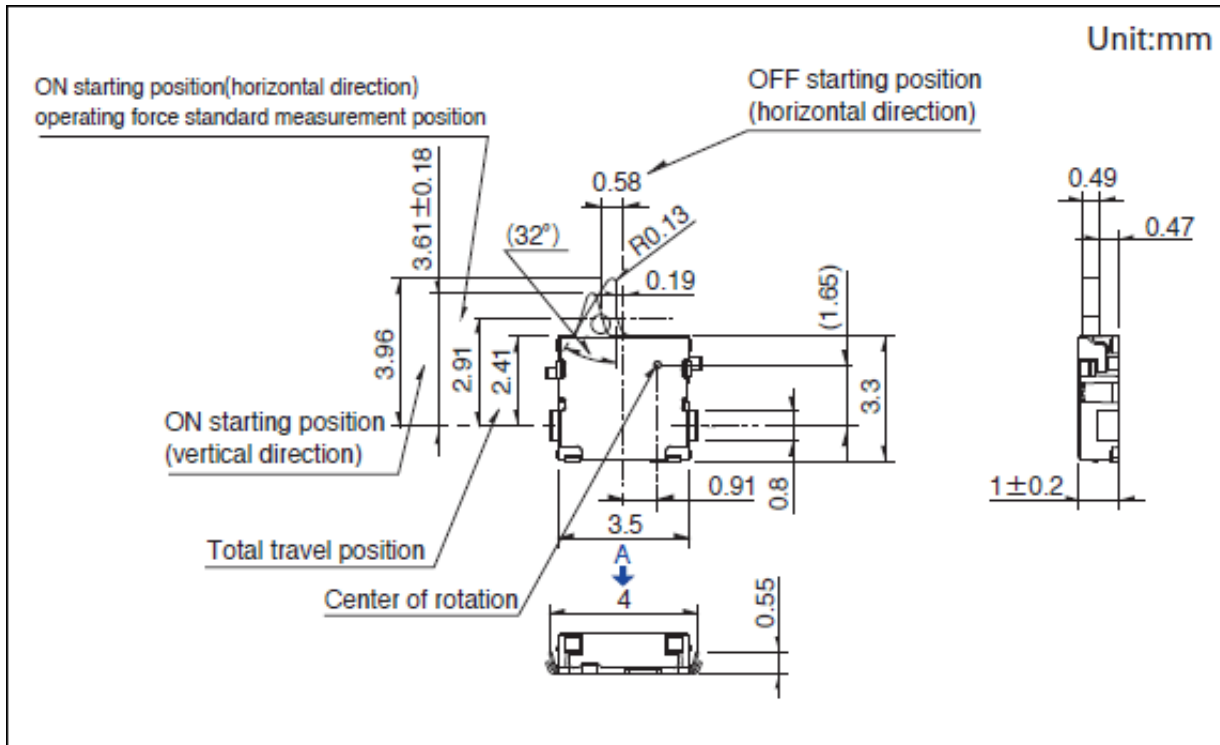

## Backside

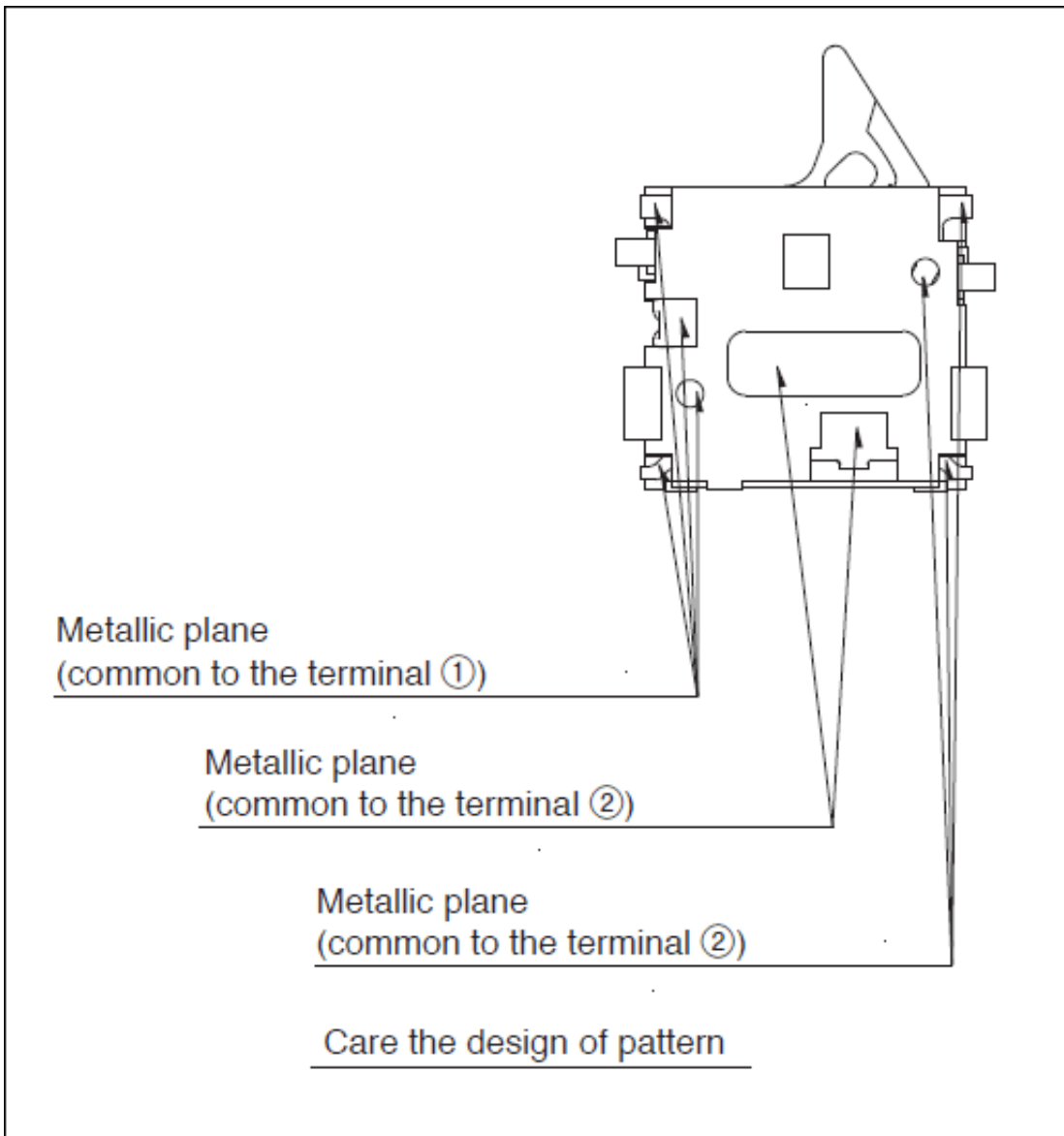

### Land Dimensions

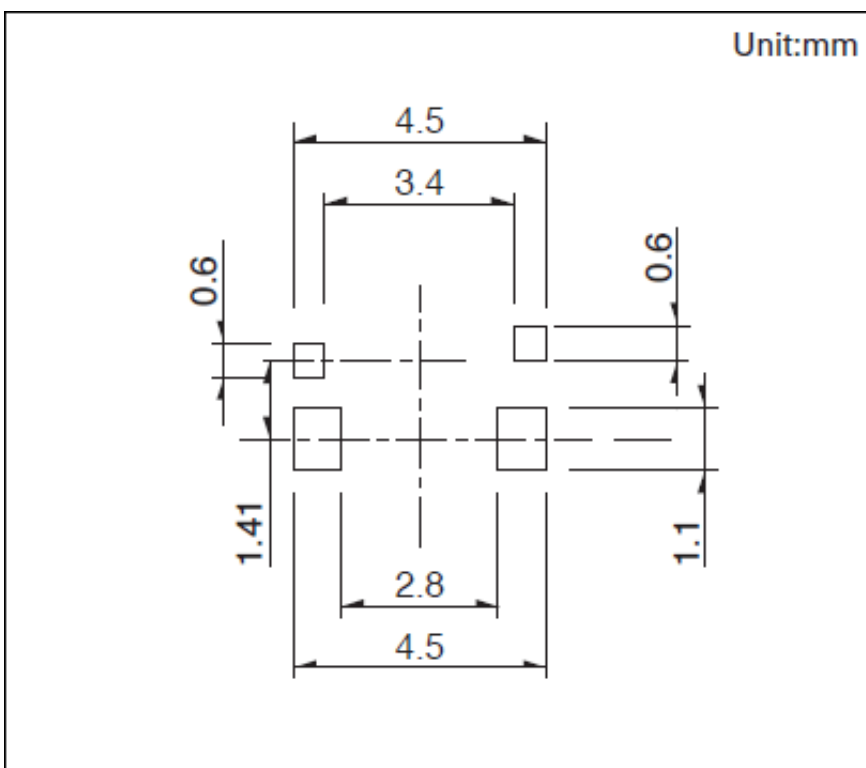

Viewed from direction A in the dimensions.

## Terminal Layout

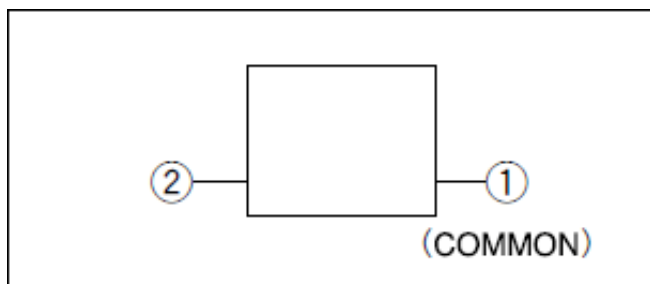

## Circuit Diagram

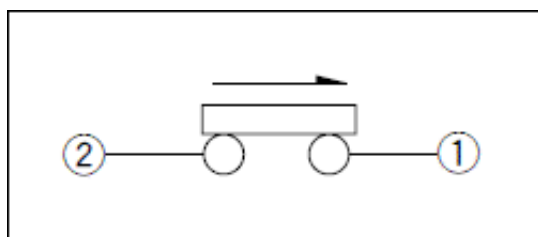

## Packing Specifications

### Taping

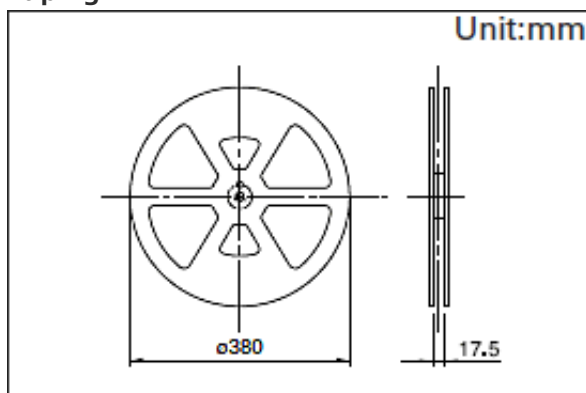

Number of packages 1 reel 5,000  
(pcs.)

1 case / Japan 10,000

1 case / export  
packing 20,000

Tape width (mm) 16

Export package measurements (mm) 417×409×139

## Soldering Conditions

### Example of Reflow Soldering Condition

#### 1. Heating method

Double heating method with infrared heater.

2. Temperature measurement

Thermocouple 0.1 to 0.2VCA (K) or CC (T) at soldering portion (copper foil surface) . A heat resisting tape should be used for fixed measurement.

3. Temperature profile

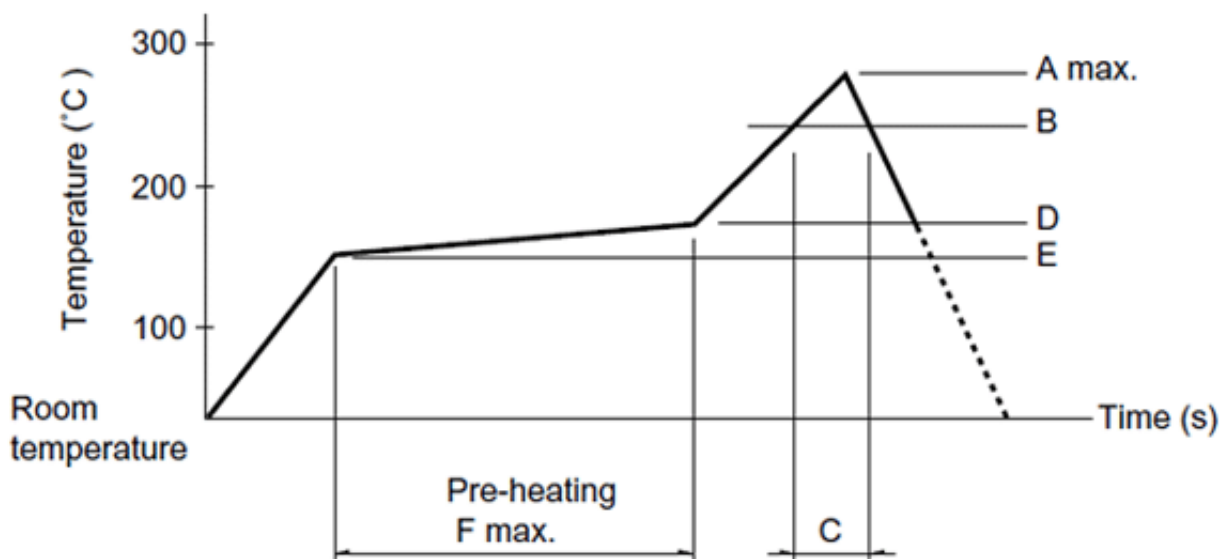

A(°C)	B(°C)	C(s)	D(°C)	E(°C)	F(s)
3s max.					
260	230	40	180	150	120

(1) The condition mentioned above is the temperature on the mounting surface of a PC board. There are cases where the PC board's temperature greatly differs from that of the switch, surface depending on the PC board's material, size, thickness, etc. The above-stated conditions shall also apply to switch surface temperatures.

(2) Soldering conditions differ depending on reflow soldering machines. Prior verification of soldering condition is highly recommended.

**Reference for Hand Soldering**

Soldering temperature	350±5°C
Soldering time	3s max.

**Notes are common to this series/models.**

1. This site catalog shows only outline specifications. When using the products, please obtain formal specifications for supply.
2. Please place purchase orders per minimum order unit (integer).
3. This products can be used in vehicles.  
Although these products are designed to perform over a wide operating temperature range, please ensure that you receive and read the formal delivery specifications before use.