



6.0mm Square Type (Snap-in) SKHH Series

Joint stem type

Type	Snap-in	
Operating force	2.55N	
Operating direction	Top push	
Travel	0.25mm	
Operating life (5mA 5V DC)	200,000 cycles	
Initial contact resistance	100mΩ max.	
Stem color	Red	
Stem height	h=7.3mm	
Series type	Sharp feeling type	
Operating temperature range	-40°C to +90°C	
Rating (max.)	50mA 12V DC	
Rating (min.)	10μA 1V DC	
Electrical performance	Insulation resistance	100MΩ min. 100V DC for 1min.
	Voltage proof	250V AC for 1 min.
Durability	Vibration	10 to 55 to 10Hz/min., the amplitude is 1.5mm for all the frequencies, in the 3 direction of X, Y and Z for 2 hours respectively
Environmental performance	Cold	-40±2°C for 96h
	Dry heat	90±2°C for 96h
	Damp heat	60±2°C, 90 to 95%RH for 96h
Minimum order unit (pcs.)	Japan	1,000
	Export	1,000

Dimensions

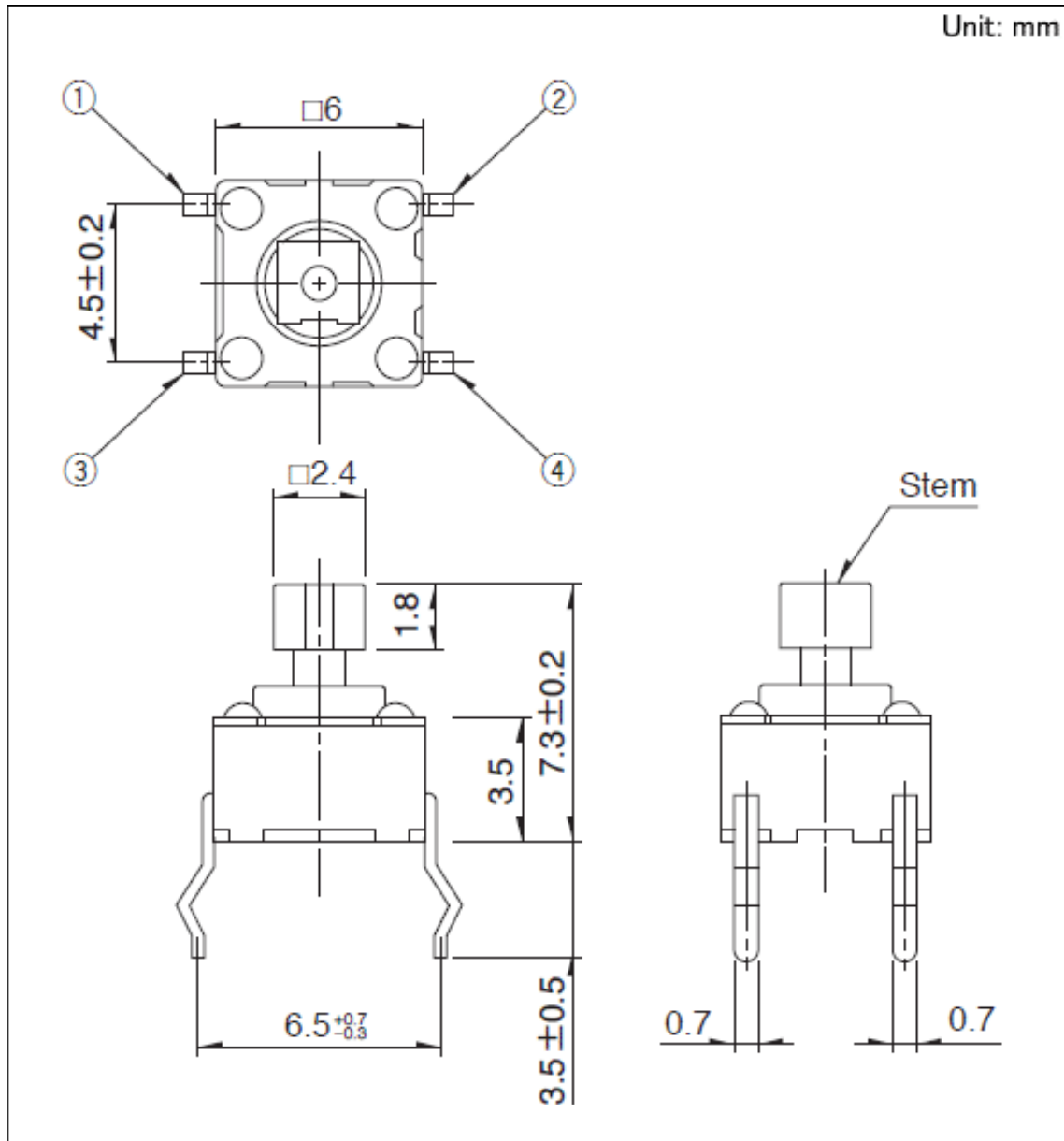

Mounting Hole Dimensions

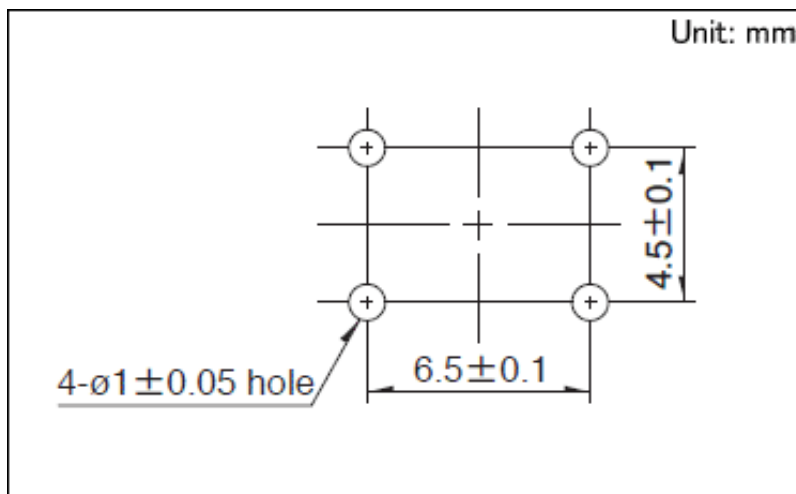

Viewed from mounting face.

Circuit Diagram

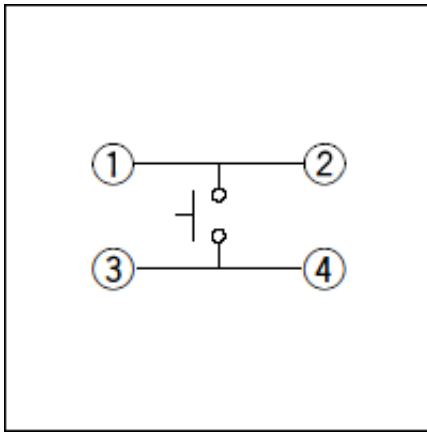

Packing Specifications

Bulk

Number of packages (pcs.)	1 case / Japan	10,000
	1 case / export packing	30,000
Export package measurements (mm)		309×476×347

Soldering Conditions

Conditions for Auto-dip

Items	Condition
Flux built-up	Mounting surface should not be exposed to flux
Preheating temperature	Ambient temperature of the soldered surface of PC board. 110°C max.
Preheating time	60s max.
Soldering temperature	260°C max.
Duration of immersion	5s max.
Number of soldering	2 times max.

Manual Soldering

Items	Condition
Soldering temperature	360°C max.
Duration of soldering	3s max.

Capacity of soldering iron

60W max.

1. Consult with us for availability of TACT switch™ washing.
2. Prevent flux penetration from the top side of the TACT switch™.
3. Switch terminals and a PC board should not be coated with flux prior to soldering.
4. The second soldering should be done after the switch returns to normal temperature.
5. Use the flux with a specific gravity of at least 0.81.
(EC-19s-8 by TAMURA Corporation, or their equivalents.)

Products Line of Knob

Dimensions (Unit: mm)

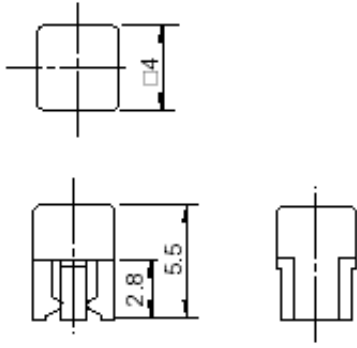
		
Keytop		
Red Blue Ivory Black Yellow	SK2AA00410 SK2AA00420 SK2AA00430 SK2AA00440 SK2AA00450	

1. The knob will be delivered together with the switch but packed separately.
2. The label is not included.

Notes are common to this series/models.

1. This site catalog shows only outline specifications. When using the products, please obtain formal specifications for supply.
2. Please use 1.6mm thick PC boards.
3. Please place purchase orders per minimum order unit (integer).
4. This products can be used in vehicles.
Although these products are designed to perform over a wide operating temperature range, please ensure that you receive and read the formal delivery specifications before use.