

Force Sensor HSFPAR Series

Part number	HSFPAR003A
Size	2.0×1.6×0.66mm
Features	High-sensitivity load detection with a compact package
Force range	0 to 8N
Supply voltage	1.5 to 3.6V
Impact resistance	50N
Minimum order unit (pcs)	3,000
Operating temperature range	-40°C to +85°C
Sensitivity	3.7mV/N
Linearity	<3% FS
Operating life	1,000,000 cycles

Photo

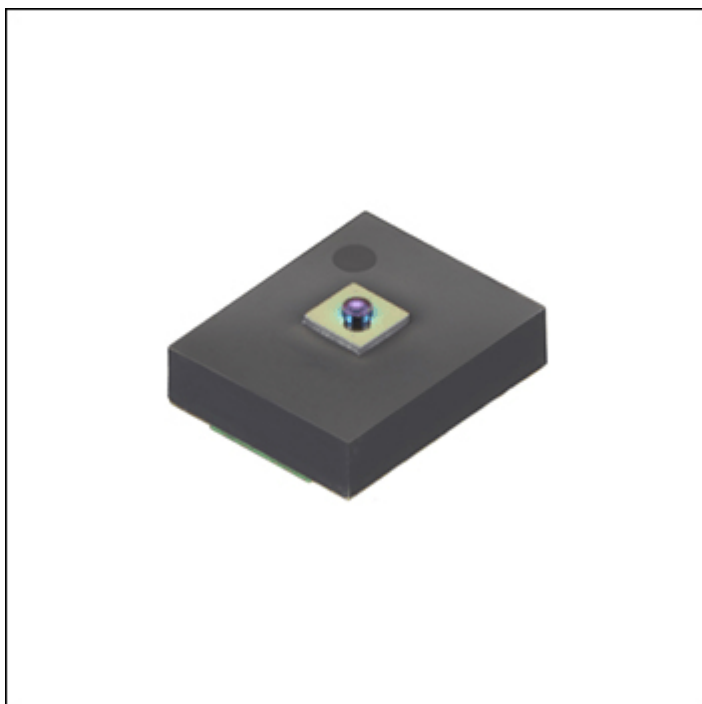
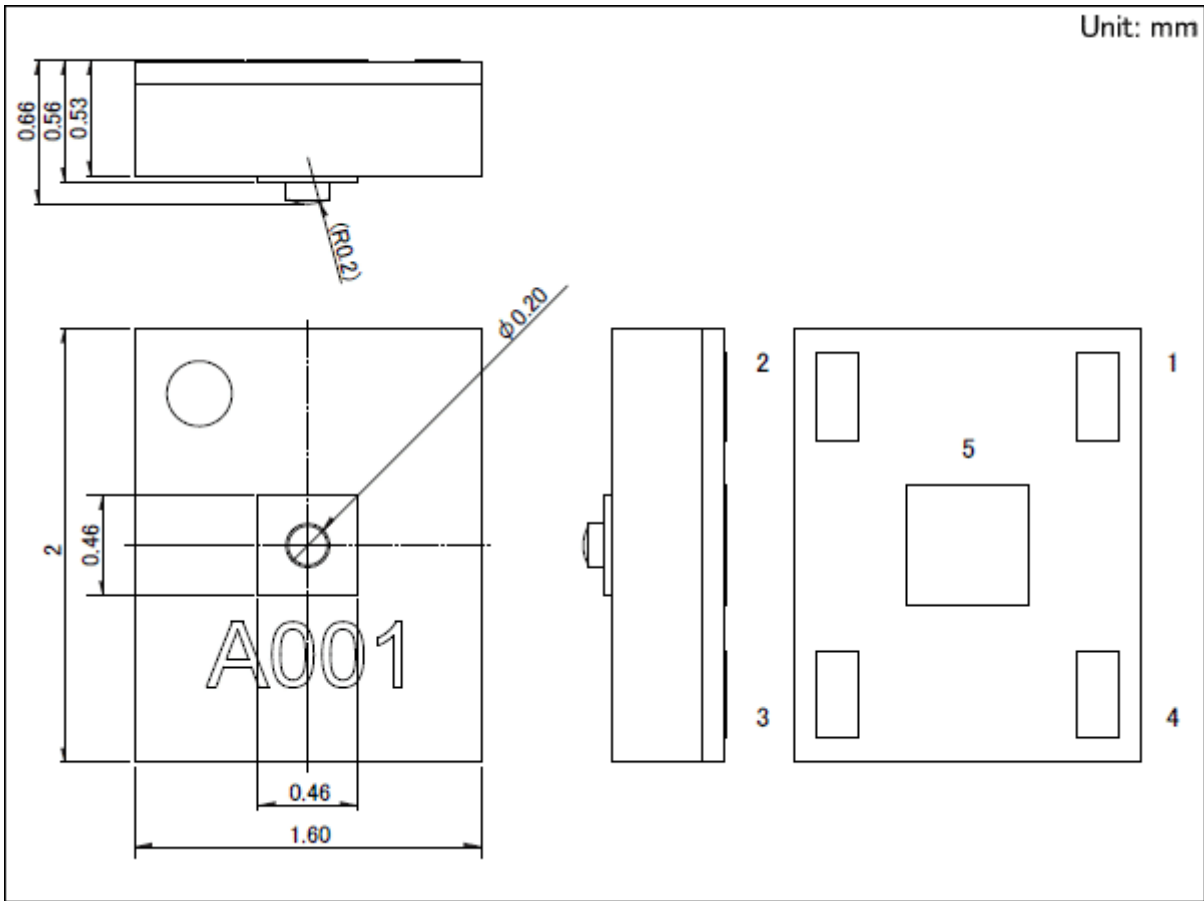

Dimensions



Packing Specifications

Taping

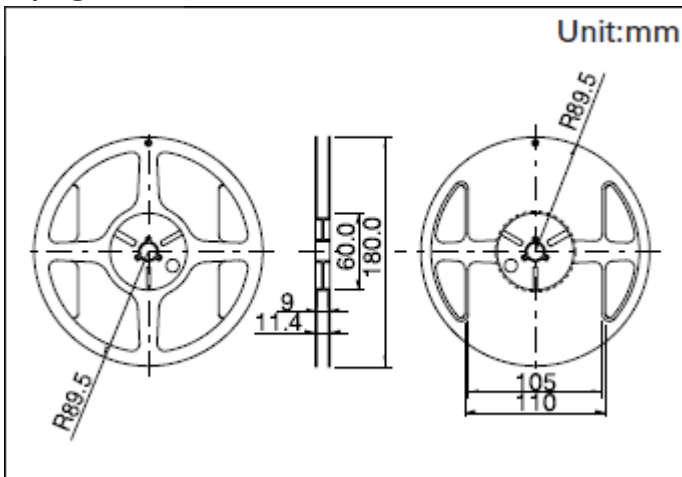

Number of packages 1 Reel 3,000
(pcs.)

1 case / Japan 3,000

1 case / export packing 45,000

Tape width (mm) 8

Export package measurements (mm) 210×210×230

Notes are common to this series/models.

1. This site catalog shows only outline specifications. When using the products, please obtain formal specifications for supply.
2. Please place purchase orders per minimum order unit (integer).