

DRV8833C 双路 H 桥电机驱动器

1 特性

- 带电流控制的双 H 桥电机驱动器
 - 1 个或 2 个直流电机或者 1 个步进电机
 - 低导通电阻：高侧 + 低侧 (HS + LS) = 1735mΩ (25°C 时的典型值)
- 输出电流能力 ($V_M = 5V$, 25°C 时)
 - 散热薄型小外形尺寸 PWP (HTSSOP) 封装
 - 每个 H 桥的均方根 (RMS) 电流为 0.7A, 峰值 1A
 - 并行模式下 RMS 为 1.4A
 - 四方扁平无引线 RTE (QFN) 封装
 - 每个 H 桥的均方根 (RMS) 电流为 0.6A, 峰值 1A
 - 并行模式下 RMS 为 1.2A
- 宽电源电压范围
 - 2.7V 至 10.8V
- 集成电流调节
- 简易脉宽调制 (PWM) 接口
- 1.6μA 低电流睡眠模式 (电压 5V 时)
- 小型封装尺寸
 - 16HTSSOP (PowerPAD™) 5.00 × 6.40mm
 - 16 QFN (PowerPAD) 3.00 × 3.00mm
- 保护特性
 - V_M 欠压闭锁 (UVLO)
 - 过流保护 (OCP)
 - 热关断 (TSD)
 - 故障指示引脚 (nFAULT)

2 应用

- 销售点打印机
- 视频安保摄像机
- 办公自动化设备
- 游戏机
- 机器人
- 电池供电式玩具

3 说明

DRV8833C 为玩具、打印机及其他机电一体化应用提供了一款双桥电机驱动器解决方案。

该器件具有两个 H 桥驱动器，能够驱动两个直流电刷电机、一个双极性步进电机、螺线管或其它电感性负载。

每个 H 桥输出都包括一对 N 通道和 P 通道金属氧化物半导体场效应晶体管 (MOSFET) 以及用于调节绕组电流的电路。借助正确的印刷电路板 (PCB) 设计，DRV8833C 的每个 H 桥能够持续驱动高达 700mA RMS (或 DC) (在 25°C 采用 5V V_M 电源时)。该器件可支持每个 H 桥高达 1A 的峰值电流。在较低的 V_M 电压条件下，电流能力略有下降。

输出引脚发生故障时，还可提供用于过流保护、短路保护、UVLO 和过热保护的内部关断功能。另外，还提供了一种低功耗睡眠模式。

器件信息(1)

部件号	封装	封装尺寸 (标称值)
DRV8833C	HTSSOP (16)	5.00mm x 6.40mm
	四方扁平无引线 (QFN) (16)	3.00mm x 3.00mm

(1) 要了解所有可用封装，请见数据表末尾的可订购产品附录。

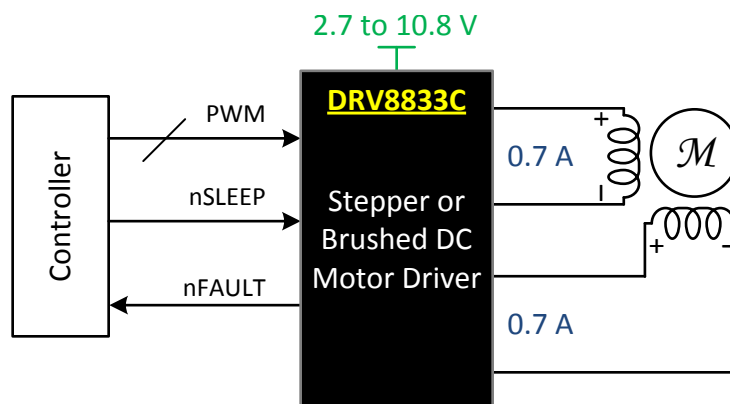

目录

1	特性	1	7.3	Feature Description	9
2	应用	1	7.4	Device Functional Modes	13
3	说明	1	8	Application and Implementation	14
4	修订历史记录	2	8.1	Application Information	14
5	Pin Configuration and Functions	3	8.2	Typical Application	14
6	Specifications	4	9	Power Supply Recommendations	17
6.1	Absolute Maximum Ratings	4	9.1	Sizing Bulk Capacitance for Motor Drive Systems ..	17
6.2	Handling Ratings	4	10	Layout	18
6.3	Recommended Operating Conditions	4	10.1	Layout Guidelines	18
6.4	Thermal Information	5	10.2	Layout Example	18
6.5	Electrical Characteristics	5	11	器件和文档支持	19
6.6	Typical Characteristics	7	11.1	商标	19
7	Detailed Description	8	11.2	静电放电警告	19
7.1	Overview	8	11.3	术语表	19
7.2	Functional Block Diagram	8	12	机械封装和可订购信息	19

4 修订历史记录

日期	修订版本	注释
2014 年 8 月	*	最初发布。

5 Pin Configuration and Functions

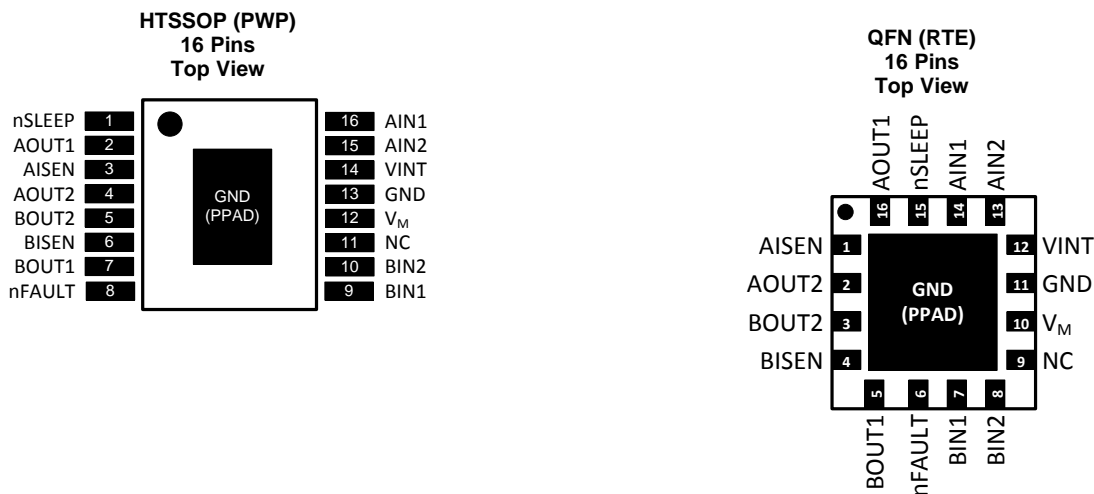

Pin Functions

PIN			TYPE	DESCRIPTION	
NAME	PWP	RTE			
POWER AND GROUND					
GND	13	11	PWR	Device ground	Both the GND pin and device PowerPAD must be connected to ground
VINT	14	12	—	Internal regulator (3.3 V)	Internal supply voltage; bypass to GND with 2.2- μ F, 6.3-V capacitor
V _M	12	10	PWR	Power supply	Connect to motor supply voltage; bypass to GND with a 10- μ F (minimum) capacitor rated for V _M
CONTROL					
AIN1	16	14	I	H-bridge A PWM input	Controls the state of AOUT1 and AOUT2; internal pulldown
AIN2	15	13			
BIN1	9	7	I	H-bridge B PWM input	Controls the state of BOUT1 and BOUT2; internal pulldown
BIN2	10	8			
nSLEEP	1	15	I	Sleep mode input	Logic high to enable device; logic low to enter low-power sleep mode; internal pulldown
STATUS					
nFAULT	8	6	OD	Fault indication pin	Pulled logic low with fault condition; open-drain output requires an external pullup
OUTPUT					
AISEN	3	1	O	Bridge A sense	Sense resistor to GND sets PWM current regulation level (see PWM Motor Drivers)
AOUT1	2	16	O	Bridge A output	Positive current is AOUT1 \rightarrow AOUT2
AOUT2	4	2			
BISEN	6	4	O	Bridge B sense	Sense resistor to GND sets PWM current regulation level (see PWM Motor Drivers)
BOUT1	7	5	O	Bridge B output	Positive current is BOUT1 \rightarrow BOUT2
BOUT2	5	3			

External Components

Component	Pin 1	Pin 2	Recommended
C _{VM}	V _M	GND	10-μF ⁽¹⁾ ceramic capacitor rated for V _M
C _{VINT}	VINT	GND	6.3-V, 2.2-μF ceramic capacitor
R _{nFAULT}	VINT ⁽²⁾	nFAULT	>1 kΩ
R _{AISEN}	AISEN	GND	Sense resistor, see Typical Application for sizing
R _{BISEN}	BISEN	GND	Sense resistor, see Typical Application for sizing

- (1) Proper bulk capacitance sizing depends on the motor power.
 (2) nFAULT may be pulled up to an external supply rated < 5.5 V.

6 Specifications

6.1 Absolute Maximum Ratings

over operating free-air temperature (unless otherwise noted) ⁽¹⁾

		MIN	MAX	UNIT
Voltage	Power supply (V _M)	-0.3	11.8	V
	Internal regulator (VINT)	-0.3	3.8	V
	Control pins (AIN1, AIN2, BIN1, BIN2, nSLEEP, nFAULT)	-0.3	7	V
	Continuous phase node pins (AOUT1, AOUT2, BOUT1, BOUT2)	-0.3	V _M + 0.5	V
	Pulsed 10 μs phase node pins (AOUT1, AOUT2, BOUT1, BOUT2)	-1	V _M + 1	V
	Continuous shunt amplifier input pins (AISEN, BISEN)	-0.3	0.5	V
	Pulsed 10 μs shunt amplifier input pins (AISEN, BISEN)	-1	1	V
Peak drive current (AOUT1, AOUT2, BOUT1, BOUT2, AISEN, BISEN)		Internally limited		A
T _J	Operating junction temperature	-40	150	°C

- (1) Stresses beyond those listed under *Absolute Maximum Ratings* may cause permanent damage to the device. These are stress ratings only, which do not imply functional operation of the device at these or any other conditions beyond those indicated under *Recommended Operating Conditions*. Exposure to absolute-maximum-rated conditions for extended periods may affect device reliability.

6.2 Handling Ratings

		MIN	MAX	UNIT	
T _{stg}	Storage temperature range	-65	150	°C	
V _(ESD)	Electrostatic discharge	Human body model (HBM), per ANSI/ESDA/JEDEC JS-001, all pins ⁽¹⁾	-2000	2000	V
		Charged device model (CDM), per JEDEC specification JESD22-C101, all pins ⁽²⁾	-1000	1000	

- (1) JEDEC document JEP155 states that 500-V HBM allows safe manufacturing with a standard ESD control process.
 (2) JEDEC document JEP157 states that 250-V CDM allows safe manufacturing with a standard ESD control process.

6.3 Recommended Operating Conditions

over operating free-air temperature range (unless otherwise noted)

		MIN	MAX	UNIT	
V _M	Power supply voltage range ⁽¹⁾	2.7	10.8	V	
V _I	Logic level input voltage	0	5.5	V	
I _{RMS}	Motor RMS current ⁽²⁾	PWP package	0	0.7	A
		RTE package	0	0.6	A
f _{PWM}	Applied PWM signal to AIN1, AIN2, BIN1, or BIN2	0	200	kHz	
T _A	Operating ambient temperature	-40	85	°C	

- (1) Note that when V_M is below 5 V, R_{DS(ON)} increases and maximum output current is reduced.
 (2) Power dissipation and thermal limits must be observed.

6.4 Thermal Information

THERMAL METRIC ⁽¹⁾		DRV8833C		UNIT
		HTSSOP	QFN	
		16 PINS	16 PINS	
R _{θJA}	Junction-to-ambient thermal resistance	40.5	44.7	°C/W
R _{θJC(top)}	Junction-to-case (top) thermal resistance	32.9	48.5	
R _{θJB}	Junction-to-board thermal resistance	28.8	16.8	
ψ _{JT}	Junction-to-top characterization parameter	0.6	0.7	
ψ _{JB}	Junction-to-board characterization parameter	11.5	16.7	
R _{θJC(bot)}	Junction-to-case (bottom) thermal resistance	4.8	4.2	

(1) For more information about traditional and new thermal metrics, see the *IC Package Thermal Metrics* application report, [SPRA953](#).

6.5 Electrical Characteristics

over operating free-air temperature range (unless otherwise noted)

PARAMETER		TEST CONDITIONS	MIN	TYP	MAX	UNIT
POWER SUPPLIES (V_M, V_{INT})						
V _M	V _M operating voltage		2.7		10.8	V
I _{VM}	V _M operating supply current	V _M = 5 V, xINx low, nSLEEP high		1.7	3	mA
I _{VMQ}	V _M sleep mode supply current	V _M = 5 V, nSLEEP low		1.6	2.7	μA
t _{SLEEP}	Sleep time	nSLEEP low to sleep mode		10		μs
t _{WAKE}	Wake-up time	nSLEEP high to output transition		155		μs
t _{ON}	Turn-on time	V _M > V _{UVLO} to output transition		25		μs
V _{INT}	Internal regulator voltage	V _M = 5 V	3	3.3	3.6	V
CONTROL INPUTS (AIN1, AIN2, BIN1, BIN2, nSLEEP)						
V _{IL}	Input logic low voltage	xINx	0		0.7	V
		nSLEEP	0		0.5	
V _{IH}	Input logic high voltage	xINx	2		5.5	V
		nSLEEP	2.5		5.5	
V _{HYS}	Input logic hysteresis		350	400	650	mV
I _{IL}	Input logic low current	V _{IN} = 0 V	-1		1	μA
I _{IH}	Input logic high current	V _{IN} = 5 V			50	μA
R _{PD}	Pulldown resistance	xINx	100	150	250	kΩ
		nSLEEP	380	500	750	
t _{DEG}	Input deglitch time			575		ns
t _{PROP}	Propagation delay INx to OUTx	V _M = 5 V		1.2		μs
CONTROL OUTPUTS (nFAULT)						
V _{OL}	Output logic low voltage	I _O = 5 mA			0.5	V
I _{OH}	Output logic high leakage	R _{PULLUP} = 1 kΩ to 5 V	-1		1	μA
MOTOR DRIVER OUTPUTS (AOUT1, AOUT2, BOUT1, BOUT2)						
R _{DS(ON)}	High-side FET on-resistance	V _M = 5 V, I = 0.2 A, T _A = 25°C		1180		mΩ
		V _M = 5 V, I = 0.2 A, T _A = 85°C ⁽¹⁾		1400	1475	
		V _M = 2.7 V, I = 0.2 A, T _A = 25°C		1550		
		V _M = 2.7 V, I = 0.2 A, T _A = 85°C ⁽¹⁾		1875	1975	
R _{DS(ON)}	Low-side FET on-resistance	V _M = 5 V, I = 0.2 A, T _A = 25°C		555		mΩ
		V _M = 5 V, I = 0.2 A, T _A = 85°C ⁽¹⁾		675	705	
		V _M = 2.7 V, I = 0.2 A, T _A = 25°C		635		
		V _M = 2.7 V, I = 0.2 A, T _A = 85°C ⁽¹⁾		775	815	

(1) Not tested in production; based on design and characterization data

Electrical Characteristics (continued)

over operating free-air temperature range (unless otherwise noted)

PARAMETER		TEST CONDITIONS	MIN	TYP	MAX	UNIT
I_{OFF}	Off-state leakage current	$V_M = 5\text{ V}$	-1		1	μA
t_{RISE}	Output rise time	$V_M = 5\text{ V}; R_L = 16\ \Omega$ to GND		70		ns
t_{FALL}	Output fall time	$V_M = 5\text{ V}; R_L = 16\ \Omega$ to V_M		80		ns
t_{DEAD}	Output dead time	Internal dead time		450		ns
PWM CURRENT CONTROL (AISEN, BISEN)						
V_{TRIP}	xISEN trip voltage		160	200	240	mV
t_{OFF}	Current control constant off time	Internal PWM constant off time		20		μs
PROTECTION CIRCUITS						
V_{UVLO}	V_M undervoltage lockout	V_M falling; UVLO report			2.6	V
		V_M rising; UVLO recovery			2.7	
$V_{UVLO,HYS}$	V_M undervoltage hysteresis	Rising to falling threshold		90		mV
I_{OCP}	Overcurrent protection trip level		1			A
t_{DEG}	Overcurrent deglitch time			2.3		μs
t_{OCP}	Overcurrent protection period			1.4		ms
$T_{TSD}^{(1)}$	Thermal shutdown temperature	Die temperature, T_J	150			$^{\circ}\text{C}$
T_{HYS}	Thermal shutdown hysteresis	Die temperature, T_J		20		$^{\circ}\text{C}$

6.6 Typical Characteristics

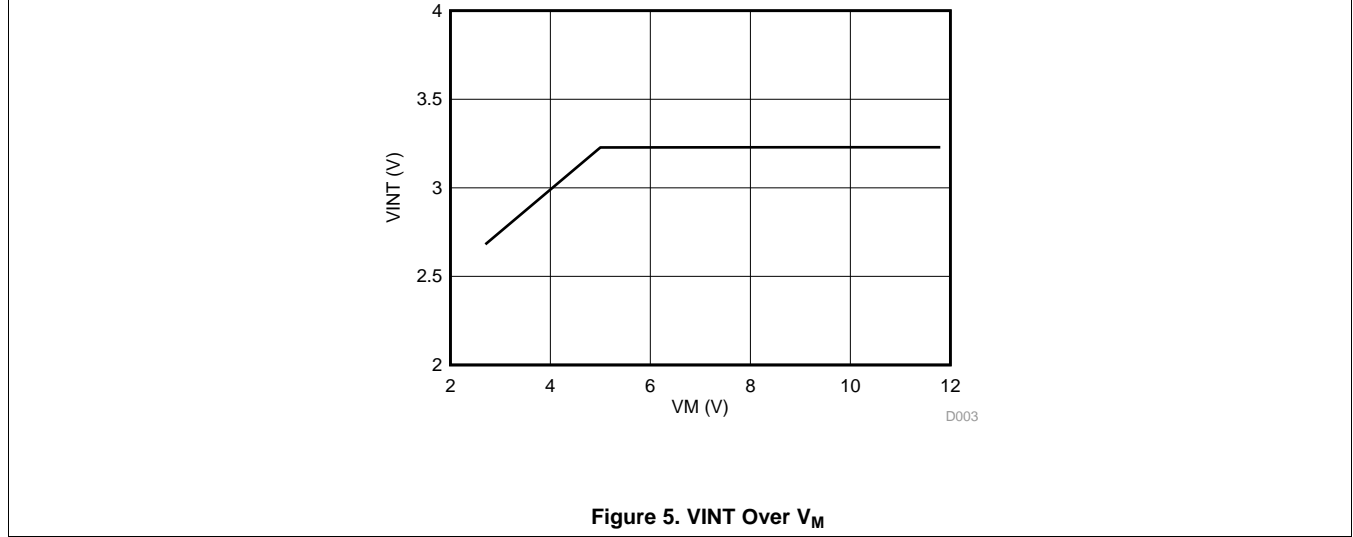
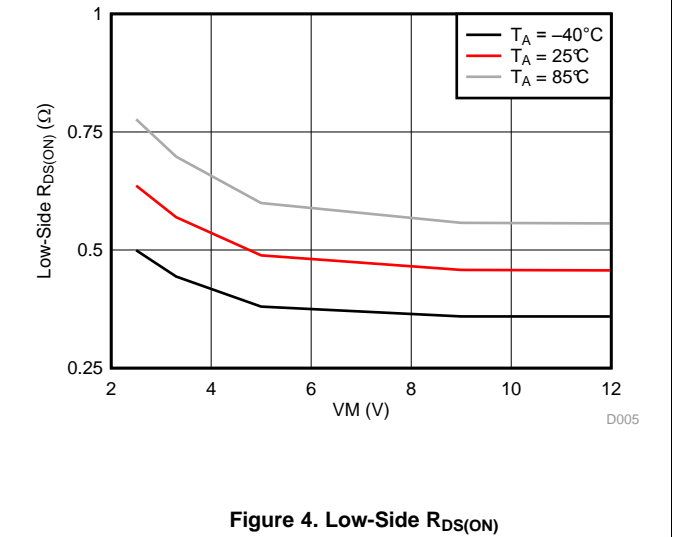
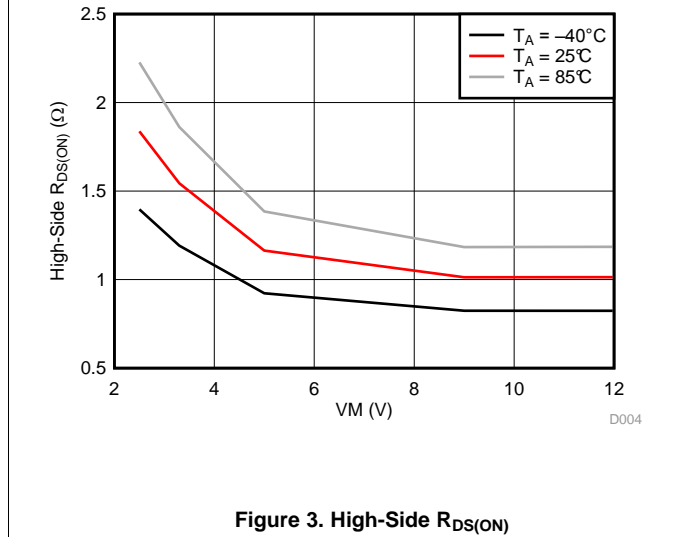
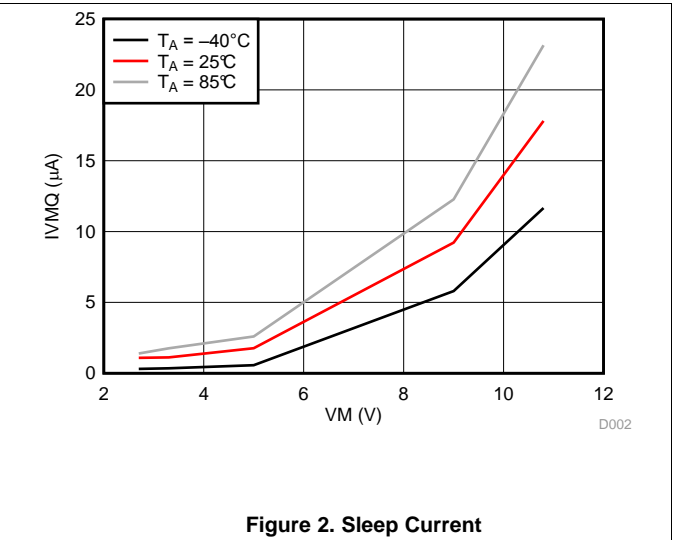
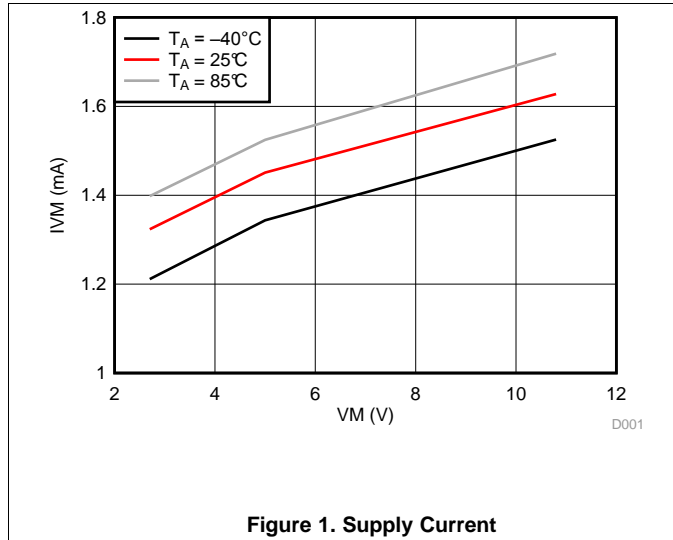

7 Detailed Description

7.1 Overview

The DRV8833C device is an integrated motor driver solution for brushed DC or bipolar stepper motors. The device integrates two PMOS + NMOS H-bridges and current regulation circuitry. The DRV8833C can be powered with a supply voltage from 2.7 to 10.8 V and can provide an output current up to 700 mA RMS.

A simple PWM interface allows easy interfacing to the controller circuit.

The current regulation is a 20- μ s fixed off-time slow decay.

The device includes a low-power sleep mode, which lets the system save power when not driving the motor.

7.2 Functional Block Diagram

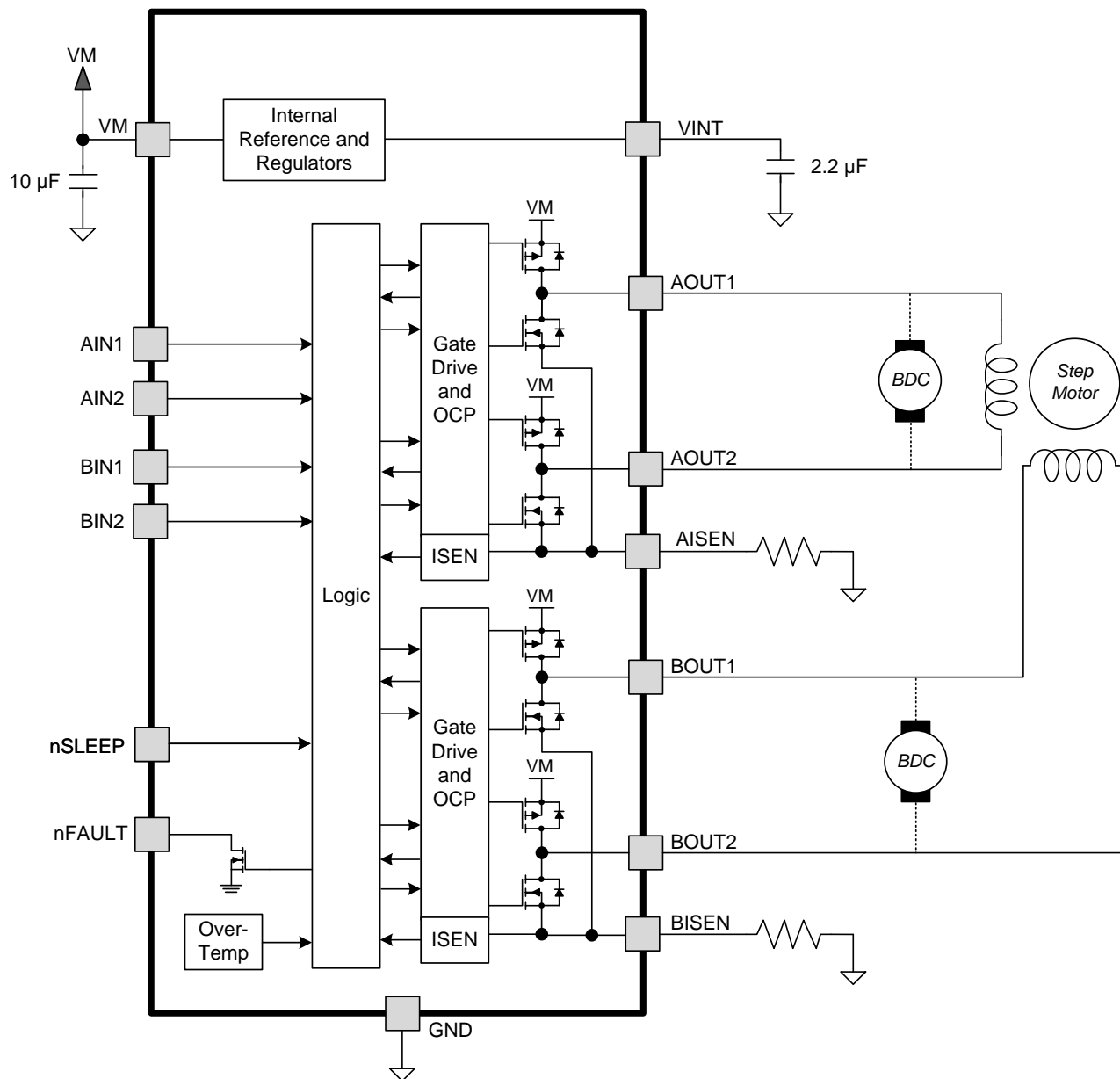

7.3 Feature Description

7.3.1 PWM Motor Drivers

The DRV8833C contains drivers for two full H-bridges. Figure 6 shows a block diagram of the circuitry.

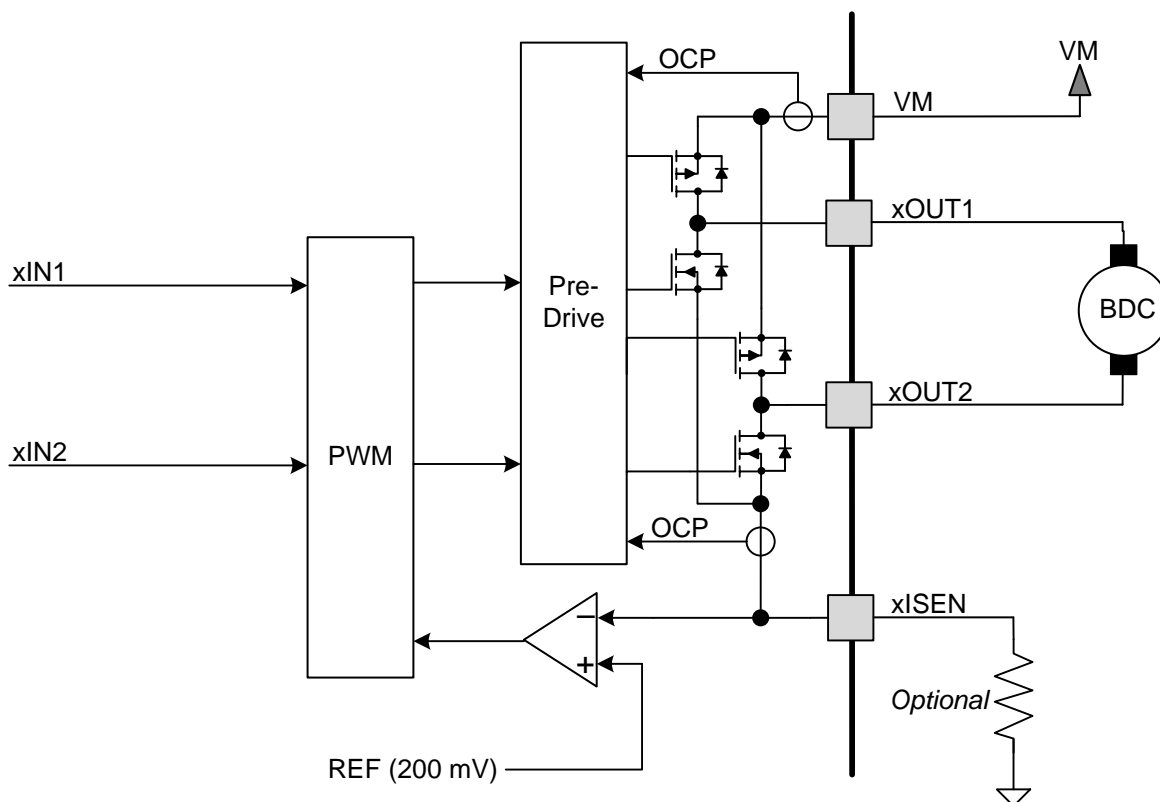

Figure 6. H-Bridge and Current-Chopping Circuitry

7.3.2 Bridge Control and Decay Modes

The AIN1 and AIN2 input pins control the state of the AOUT1 and AOUT2 outputs; similarly, the BIN1 and BIN2 input pins control the state of the BOUT1 and BOUT2 outputs (see Table 1).

Table 1. H-Bridge Logic

xIN1	xIN2	xOUT1	xOUT2	FUNCTION
0	0	Z	Z	Coast / fast decay
0	1	L	H	Reverse
1	0	H	L	Forward
1	1	L	L	Brake / slow decay

The inputs can also be used for PWM control of the motor speed. When controlling a winding with PWM and the drive current is interrupted, the inductive nature of the motor requires that the current must continue to flow (called recirculation current). To handle this recirculation current, the H-bridge can operate in two different states, fast decay or slow decay. In fast-decay mode, the H-bridge is disabled and recirculation current flows through the body diodes. In slow-decay mode, the motor winding is shorted by enabling both low-side FETs.

To externally pulse-width modulate the bridge in fast-decay mode, the PWM signal is applied to one xIN pin while the other is held low; to use slow-decay mode, one xIN pin is held high. See Table 2 for more information.

Table 2. PWM Control of Motor Speed

xIN1	xIN2	FUNCTION
PWM	0	Forward PWM, fast decay
1	PWM	Forward PWM, slow decay
0	PWM	Reverse PWM, fast decay
PWM	1	Reverse PWM, slow decay

The internal current control is still enabled when applying external PWM to xIN. To disable the current control when applying external PWM, the xISEN pins should be connected directly to ground. Figure 7 show the current paths in different drive and decay modes.

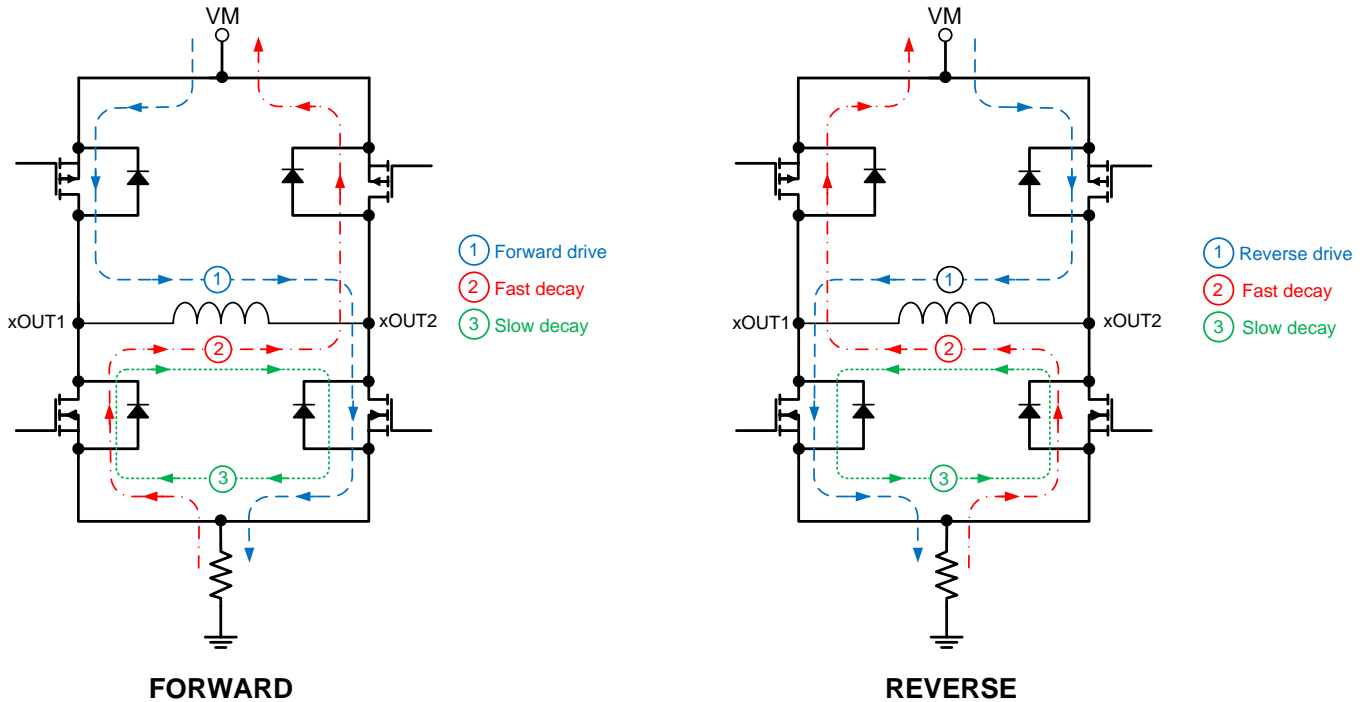

Figure 7. Drive and Decay Modes

7.3.3 Current Control

The current through the motor windings may be limited, or controlled, by a 20-μs constant off-time PWM current regulation, or current chopping. For DC motors, current control is used to limit the start-up and stall current of the motor. For stepper motors, current control is often used at all times.

When an H-bridge is enabled, current rises through the winding at a rate dependent on the DC voltage and inductance of the winding. If the current reaches the current chopping threshold, the bridge disables the current until the beginning of the next PWM cycle. Note that immediately after the output is enabled, the voltage on the xISEN pin is ignored for a fixed period of time before enabling the current sense circuitry. This blanking time is fixed at 3.75 μs.

The PWM chopping current is set by a comparator that compares the voltage across a current sense resistor connected to the xISEN pins with a reference voltage. The reference voltage, V_{TRIP}, is fixed at 200 mV nominally.

The chopping current is calculated as in Equation 1.

$$I_{CHOP} = \frac{200 \text{ mV}}{R_{XISEN}} \tag{1}$$

Example: If a 1-Ω sense resistor is used, the chopping current will be 200 mV / 1 Ω = 200 mA.

NOTE

If current control is not needed, the xISEN pins should be connected directly to ground.

7.3.4 Decay Mode

After the chopping current threshold is reached, the H-bridge switches to slow-decay mode. This state is held for t_{off} (20 μ s) until the next cycle to turn on the high-side MOSFETs.

7.3.5 Slow Decay

In slow-decay mode, the high-side MOSFETs are turned off and both of the low-side MOSFETs are turned on. The motor current decreases while flowing in the two low-side MOSFETs until reaching its fixed off time (typically 20 μ s). After that, the high-side MOSFETs are enabled to increase the winding current again.

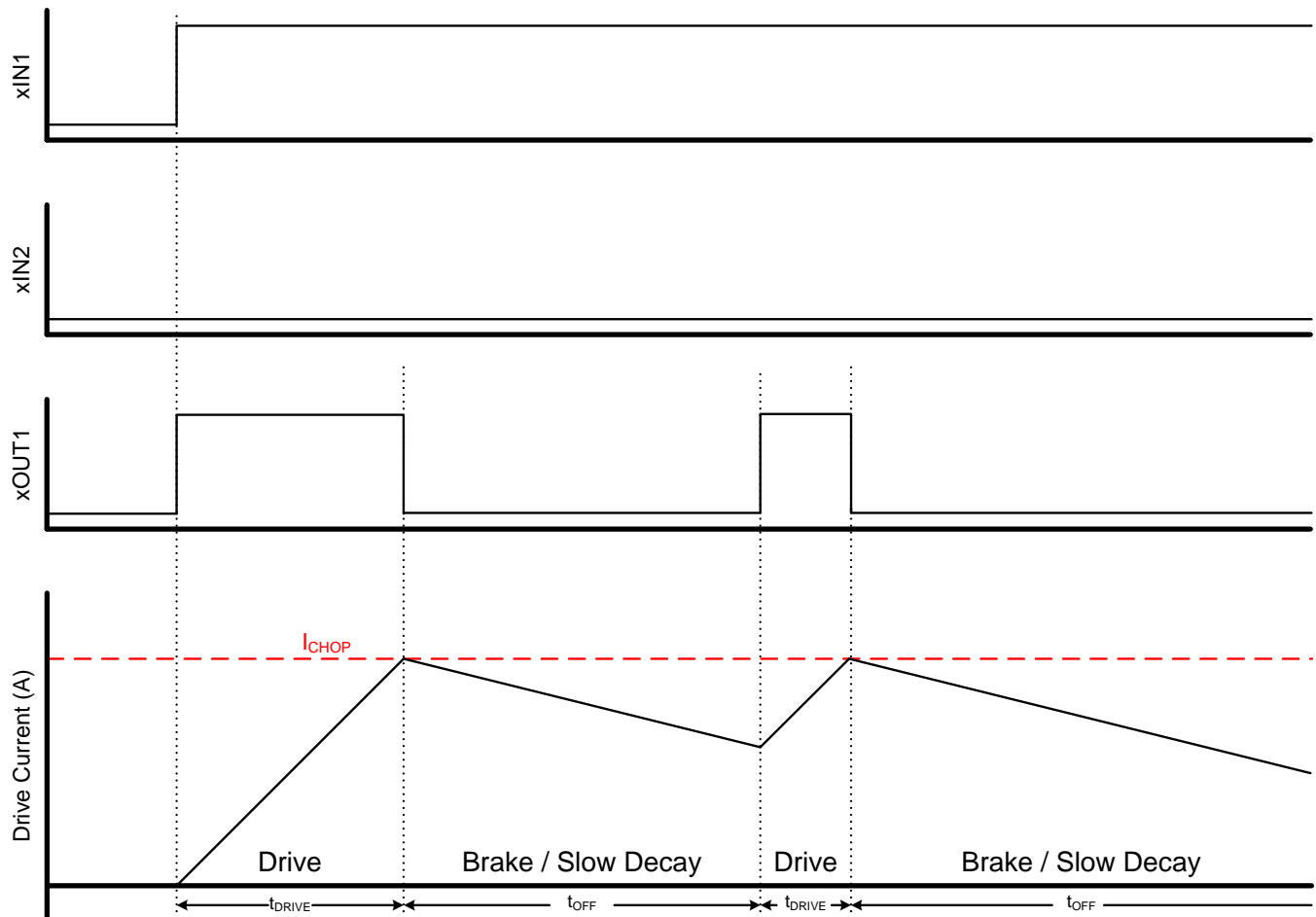

Figure 8. Current Chopping Operation

7.3.6 Sleep Mode

Driving nSLEEP low puts the device into a low-power sleep state. In this state, the H-bridges are disabled, all internal logic is reset, and all internal clocks are stopped. All inputs are ignored until nSLEEP returns inactive high. When returning from sleep mode, some time, t_{WAKE} , needs to pass before the motor driver becomes fully operational. To make the board design simple, the nSLEEP can be pulled up to the supply (V_M). TI recommends to use a pullup resistor when this is done. This resistor limits the current to the input in case V_M is higher than 6.5 V. Internally, the nSLEEP pin has a 500-k Ω resistor to GND. It also has a clamping Zener diode that clamps the voltage at the pin at 6.5 V. Currents greater than 250 μ A can cause damage to the input structure. Therefore, TI recommends a pullup resistor between 20 to 75 k Ω .

7.3.7 Parallel Mode

The two H-bridges in the DRV8833C can be connected in parallel for double the current of a single H-bridge. The internal dead time in the DRV8833C prevents any risk of cross-conduction (shoot-through) between the two bridges due to timing differences between the two bridges. Figure 9 shows the connections.

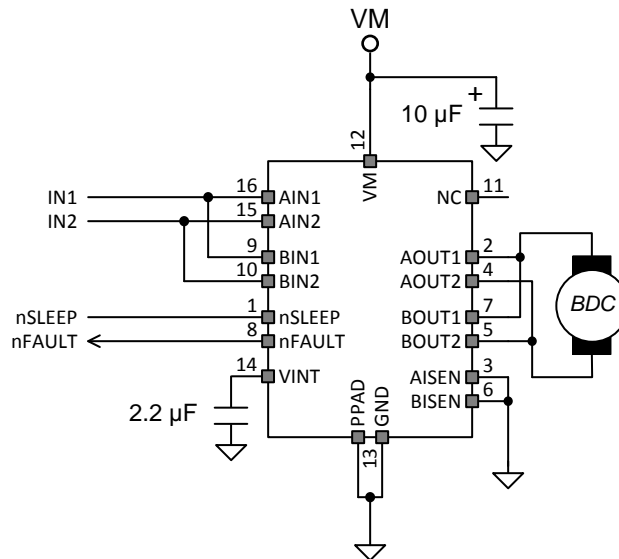

Figure 9. Parallel Mode Schematic

7.3.8 Protection Circuits

The DRV8833C is fully protected against overcurrent, overtemperature, and undervoltage events.

7.3.8.1 Overcurrent Protection (OCP)

An analog current limit (I_{OCP}) circuit on each FET limits the current through the FET by limiting the gate drive. If this analog current limit persists for longer than the OCP deglitch time (t_{DEG}), all FETs in the H-bridge are disabled and the nFAULT pin is driven low. The driver is re-enabled after the OCP retry period (t_{OCP}) has passed. nFAULT becomes high again after the retry time. If the fault condition is still present, the cycle repeats. If the fault is no longer present, normal operation resumes and nFAULT remains deasserted. Note that only the H-bridge in which the OCP is detected will be disabled while the other bridge functions normally.

Overcurrent conditions are detected independently on both high-side and low-side devices; a short to ground, supply, or across the motor winding all result in an overcurrent shutdown. Note that overcurrent protection does not use the current sense circuitry used for PWM current control, so it functions even without presence of the xISEN resistors.

7.3.8.2 Thermal Shutdown (TSD)

If the die temperature exceeds safe limits, all FETs in the H-bridge are disabled and the nFAULT pin is driven low. After the die temperature has fallen below the specified hysteresis (T_{HYS}), operation automatically resumes. The nFAULT pin is released after operation has resumed.

7.3.8.3 UVLO

If at any time the voltage on the V_M pin falls below the UVLO threshold voltage, V_{UVLO} , all circuitry in the device is disabled, and all internal logic is reset. Operation resumes when V_M rises above the UVLO threshold. The nFAULT pin is not driven low during an undervoltage condition.

Table 3. Device Protection

Fault	Condition	Error Report	H-Bridge	Internal Circuits	Recovery
V_M undervoltage (UVLO)	$V_M < 2.6\text{ V}$	None	Disabled	Disabled	$V_M > 2.7\text{ V}$
Overcurrent (OCP)	$I_{OUT} > I_{OCP}$	FAULTn	Disabled	Operating	OCP
Thermal Shutdown (TSD)	$T_J > T_{TSD}$	FAULTn	Disabled	Operating	$T_J < T_{TSD} - T_{HYS}$

7.4 Device Functional Modes

The DRV8833C is active unless the nSLEEP pin is brought logic low. In sleep mode, the H-bridge FETs are disabled (Hi-Z). Note that t_{SLEEP} must elapse after a falling edge on the nSLEEP pin before the device is in sleep mode. The DRV8833C is brought out of sleep mode automatically if nSLEEP is brought logic high. Note that t_{WAKE} must elapse before the outputs change state after wake-up.

Table 4. Modes of Operation

Fault	Condition	H-Bridge	Internal Circuits
Operating	nSLEEP pin high	Operating	Operating
Sleep mode	nSLEEP pin low	Disabled	Disabled
Fault encountered	Any fault condition met	Disabled	See Table 3

8 Application and Implementation

8.1 Application Information

The DRV8833C is used in stepper or brushed DC motor control. The following design procedure can be used to configure the DRV8833C in a bipolar stepper motor application.

8.2 Typical Application

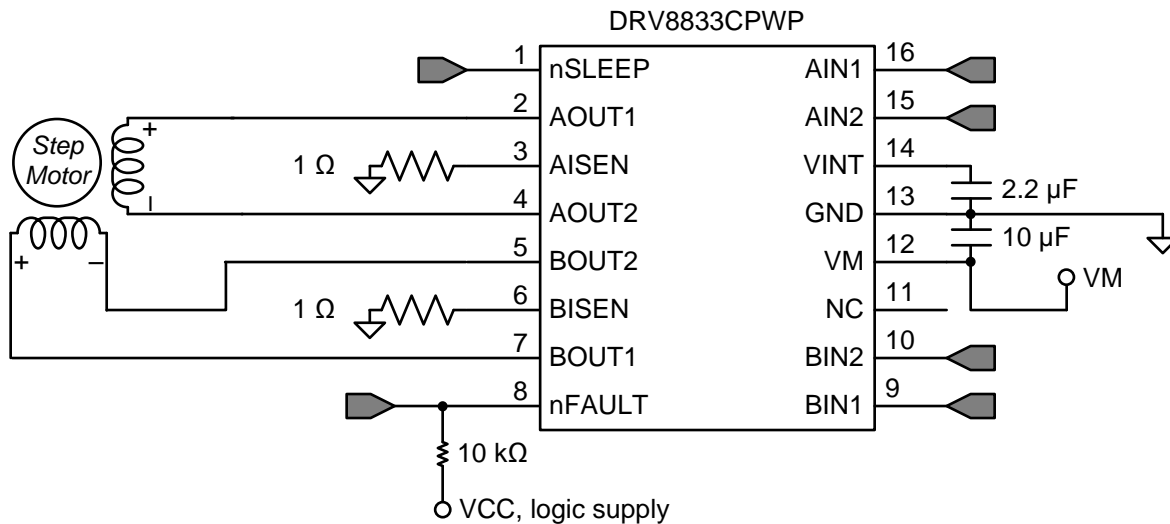

8.2.1 Design Requirements

Table 5 gives design input parameters for system design.

Table 5. Design Parameters

Design Parameter	Reference	Example Value
Supply voltage	V_M	9 V
Motor winding resistance	R_L	12 Ω /phase
Motor winding inductance	L_L	10 mH/phase
Motor full step angle	θ_{step}	1.8 $^\circ$ /step
Target stepping level	n_m	2 (half-stepping)
Target motor speed	v	120 rpm
Target chopping current	I_{CHOP}	200 mA
Sense resistor	R_{ISEN}	1 Ω

8.2.2 Detailed Design Procedure

8.2.2.1 Stepper Motor Speed

The first step in configuring the DRV8833C requires the desired motor speed and stepping level. The DRV8833C can support full- and half-stepping modes using the PWM interface.

If the target motor speed is too high, the motor does not spin. Ensure that the motor can support the target speed.

For a desired motor speed (v), microstepping level (n_m), and motor full step angle (θ_{step}),

$$f_{\text{step}} \text{ (steps / s)} = \frac{v(\text{rpm}) \times n_m \text{ (steps)} \times 360^\circ / \text{rot}}{\theta_{\text{step}} \text{ (}^\circ / \text{step)} \times 60 \text{ s / min}} \quad (2)$$

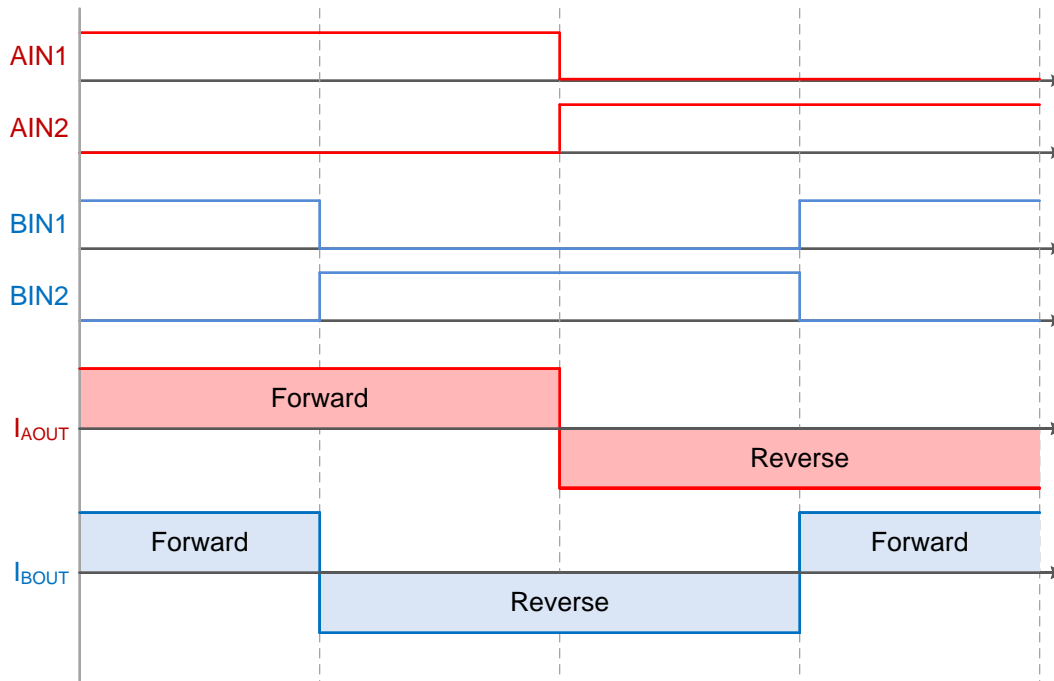

Figure 10. Full-Step Mode

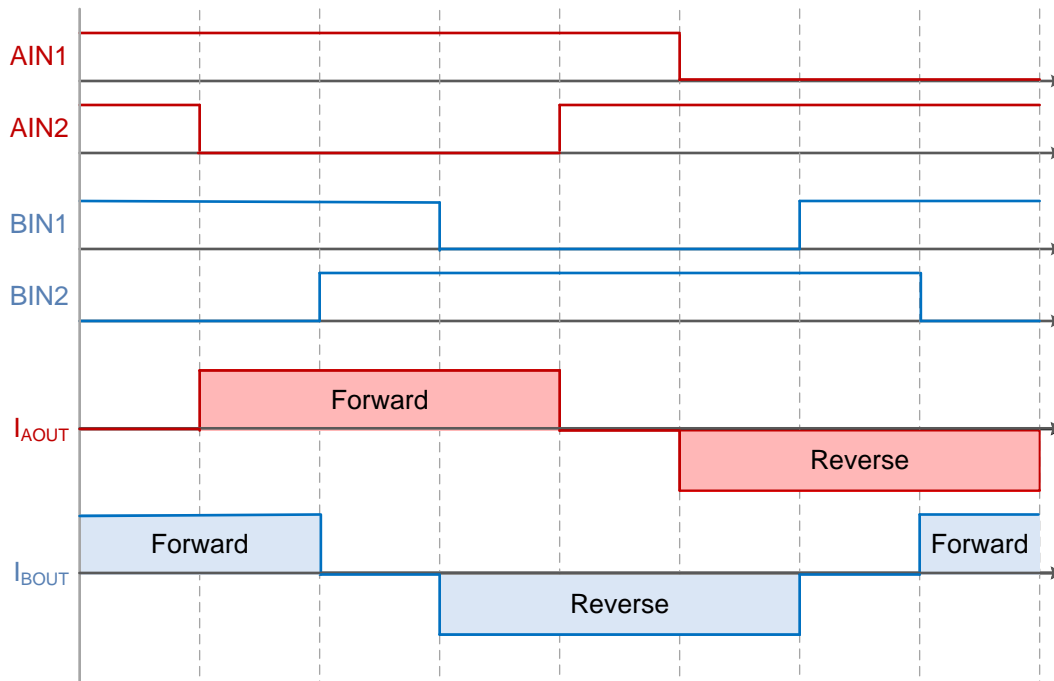

Figure 11. Half-Step Mode

8.2.2.2 Current Regulation

The chopping current (I_{CHOP}) is the maximum current driven through either winding. This quantity depends on the sense resistor value (R_{XISEN}).

$$I_{CHOP} = \frac{200 \text{ mV}}{R_{XISEN}}$$

(3)

I_{CHOP} is set by a comparator which compares the voltage across R_{XISEN} to a reference voltage. Note that I_{CHOP} must follow Equation 4 to avoid saturating the motor.

$$I_{\text{FS}} (\text{A}) < \frac{V_{\text{M}} (\text{V})}{R_{\text{L}} (\Omega) + R_{\text{DS(ON)}} \text{HS} (\Omega) + R_{\text{DS(ON)}} \text{LS} (\Omega)}$$

where

- V_{M} is the motor supply voltage.
- R_{L} is the motor winding resistance.

(4)

8.2.3 Application Curve

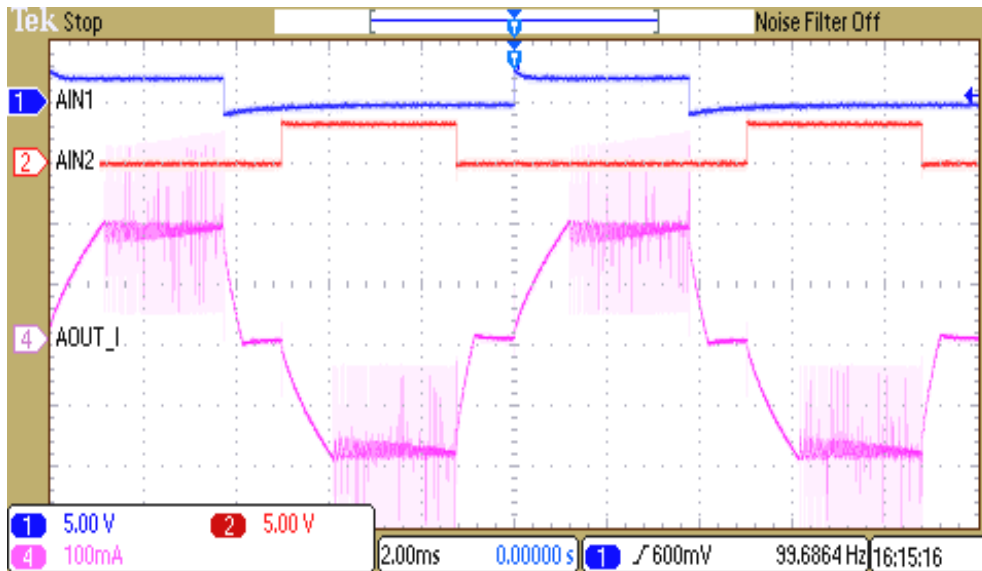

- A. Channel 1 is the AIN1 input PWM signal, and channel 2 is the AIN2 input PWM signal. BIN1 and BIN2 follow the same pattern, but are shifted by 90° from AIN1 and AIN2 as shown in Figure 11. Channel 4 is the output current in the direction AOUT1 → AOUT2. In forward and reverse drive, the current rises until it hits the current chopping limit of 200 mA, and is regulated at that level with fixed-off time current chopping.

Figure 12. ½ Stepping Operation

9 Power Supply Recommendations

The DRV8833C is designed to operate from an input voltage supply (V_M) range between 2.7 to 10.8 V. A 10- μ F ceramic capacitor rated for V_M must be placed as close to the DRV8833C as possible.

9.1 Sizing Bulk Capacitance for Motor Drive Systems

Bulk capacitance sizing is an important factor in motor drive system design. It depends on a variety of factors including:

- Type of power supply
- Acceptable supply voltage ripple
- Parasitic inductance in the power supply wiring
- Type of motor (brushed DC, brushless DC, stepper)
- Motor startup current
- Motor braking method

The inductance between the power supply and motor drive system limits the rate current can change from the power supply. If the local bulk capacitance is too small, the system responds to excessive current demands or dumps from the motor with a change in voltage. Size the bulk capacitance to meet acceptable voltage ripple levels.

The data sheet generally provides a recommended value, but system-level testing is required to determine the appropriate-sized bulk capacitor.

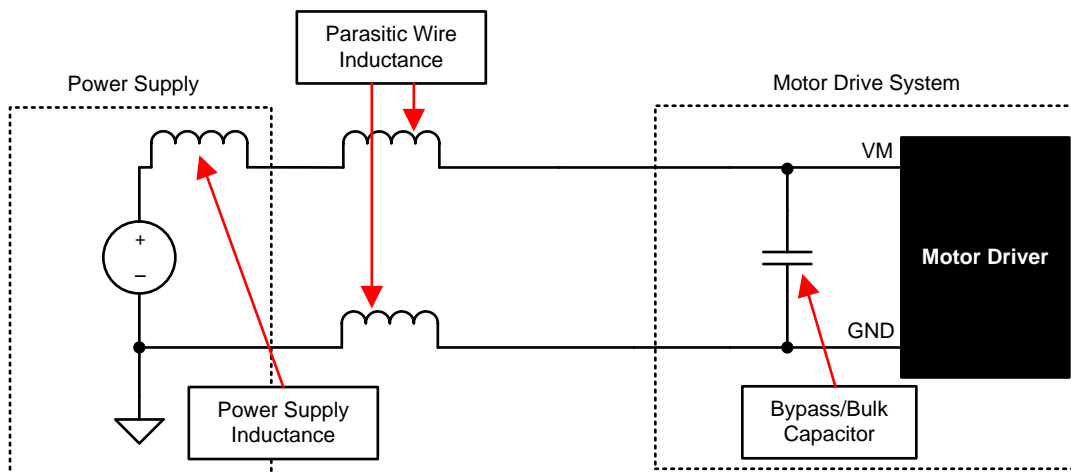

Figure 13. Setup of Motor Drive System With External Power Supply

10 Layout

10.1 Layout Guidelines

Bypass the V_M terminal to GND using a low-ESR ceramic bypass capacitor with a recommended value of $10\ \mu\text{F}$ rated for V_M . This capacitor should be placed as close to the V_M pin as possible with a thick trace or ground plane connection to the device GND pin and PowerPAD.

Bypass VINT to ground with a ceramic capacitor rated 6.3 V. Place this bypassing capacitor as close to the pin as possible.

10.2 Layout Example

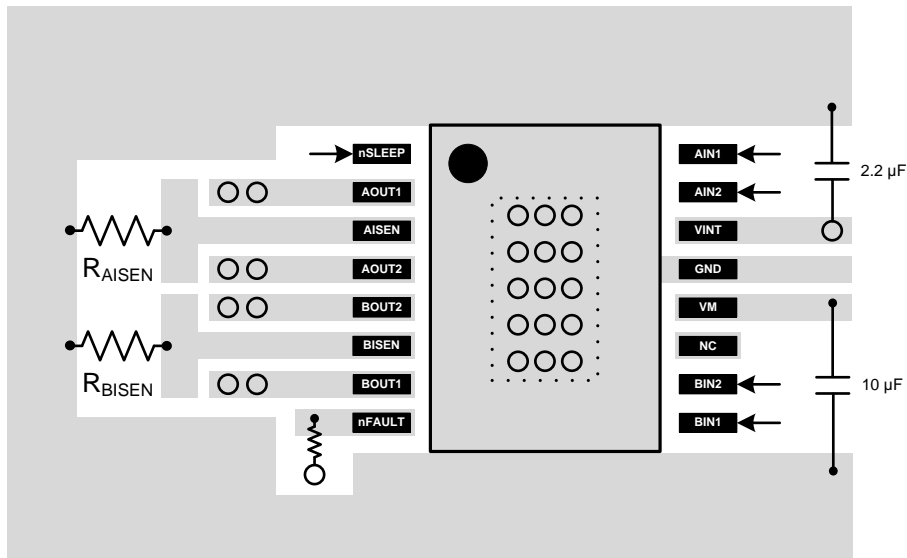

11 器件和文档支持

11.1 商标

PowerPAD is a trademark of Texas Instruments.

11.2 静电放电警告



这些装置包含有限的内置 ESD 保护。存储或装卸时，应将导线一起截短或将装置放置于导电泡棉中，以防止 MOS 门极遭受静电损伤。

11.3 术语表

[SLYZ022](#) — TI 术语表。

这份术语表列出并解释术语、首字母缩略词和定义。

12 机械封装和可订购信息

以下页中包括机械封装和可订购信息。 这些信息是针对指定器件可提供的最新数据。 这些数据会在无通知且不对本文档进行修订的情况下发生改变。 欲获得该数据表的浏览器版本，请查阅左侧的导航栏。

重要声明

德州仪器(TI)及其下属子公司有权根据 JESD46 最新标准,对所提供的产品和服务进行更正、修改、增强、改进或其它更改,并有权根据 JESD48 最新标准中止提供任何产品和服务。客户在下订单前应获取最新的相关信息,并验证这些信息是否完整且是最新的。所有产品的销售都遵循在订单确认时所提供的TI 销售条款与条件。

TI 保证其所销售的组件的性能符合产品销售时 TI 半导体产品销售条件与条款的适用规范。仅在 TI 保证的范围内,且 TI 认为有必要时才会使用测试或其它质量控制技术。除非适用法律做出了硬性规定,否则没有必要对每种组件的所有参数进行测试。

TI 对应用帮助或客户产品设计不承担任何义务。客户应对其使用 TI 组件的产品和应用自行负责。为尽量减小与客户产品和应用相关的风险,客户应提供充分的设计与操作安全措施。

TI 不对任何 TI 专利权、版权、屏蔽作品权或其它与使用了 TI 组件或服务的组合设备、机器或流程相关的 TI 知识产权中授予的直接或隐含权限作出任何保证或解释。TI 所发布的与第三方产品或服务有关的信息,不能构成从 TI 获得使用这些产品或服务的许可、授权、或认可。使用此类信息可能需要获得第三方的专利权或其它知识产权方面的许可,或是 TI 的专利权或其它知识产权方面的许可。

对于 TI 的产品手册或数据表中 TI 信息的重要部分,仅在没有对内容进行任何篡改且带有相关授权、条件、限制和声明的情况下才允许进行复制。TI 对此类篡改过的文件不承担任何责任或义务。复制第三方的信息可能需要服从额外的限制条件。

在转售 TI 组件或服务时,如果对该组件或服务参数的陈述与 TI 标明的参数相比存在差异或虚假成分,则会失去相关 TI 组件或服务的所有明示或暗示授权,且这是不正当的、欺诈性商业行为。TI 对任何此类虚假陈述均不承担任何责任或义务。

客户认可并同意,尽管任何应用相关信息或支持仍可能由 TI 提供,但他们将独立负责满足与其产品及其在应用中使用的 TI 产品相关的所有法律、法规和安全相关要求。客户声明并同意,他们具备制定与实施安全措施所需的全部专业技术和知识,可预见故障的危险后果、监测故障及其后果、降低有可能造成人身伤害的故障的发生机率并采取适当的补救措施。客户将全额赔偿因在此类安全关键应用中使用任何 TI 组件而对 TI 及其代理造成的任何损失。

在某些场合中,为了推进安全相关应用有可能对 TI 组件进行特别的促销。TI 的目标是利用此类组件帮助客户设计和创立其特有的可满足适用的功能安全性标准和要求的终端产品解决方案。尽管如此,此类组件仍然服从这些条款。

TI 组件未获得用于 FDA Class III (或类似的生命攸关医疗设备)的授权许可,除非各方授权官员已经达成了专门管控此类使用的特别协议。

只有那些 TI 特别注明属于军用等级或“增强型塑料”的 TI 组件才是设计或专门用于军事/航空应用或环境的。购买者认可并同意,对并非指定面向军事或航空航天用途的 TI 组件进行军事或航空航天方面的应用,其风险由客户单独承担,并且由客户独立负责满足与此类使用相关的所有法律和法规要求。

TI 已明确指定符合 ISO/TS16949 要求的产品,这些产品主要用于汽车。在任何情况下,因使用非指定产品而无法达到 ISO/TS16949 要求, TI 不承担任何责任。

	产品		应用
数字音频	www.ti.com.cn/audio	通信与电信	www.ti.com.cn/telecom
放大器和线性器件	www.ti.com.cn/amplifiers	计算机及周边	www.ti.com.cn/computer
数据转换器	www.ti.com.cn/dataconverters	消费电子	www.ti.com.cn/consumer-apps
DLP® 产品	www.dlp.com	能源	www.ti.com.cn/energy
DSP - 数字信号处理器	www.ti.com.cn/dsp	工业应用	www.ti.com.cn/industrial
时钟和计时器	www.ti.com.cn/clockandtimers	医疗电子	www.ti.com.cn/medical
接口	www.ti.com.cn/interface	安防应用	www.ti.com.cn/security
逻辑	www.ti.com.cn/logic	汽车电子	www.ti.com.cn/automotive
电源管理	www.ti.com.cn/power	视频和影像	www.ti.com.cn/video
微控制器 (MCU)	www.ti.com.cn/microcontrollers		
RFID 系统	www.ti.com.cn/rfidsys		
OMAP应用处理器	www.ti.com/omap		
无线连通性	www.ti.com.cn/wirelessconnectivity	德州仪器在线技术支持社区	www.deyisupport.com

邮寄地址: 上海市浦东新区世纪大道1568号, 中建大厦32楼邮政编码: 200122
Copyright © 2014, 德州仪器半导体技术(上海)有限公司

PACKAGING INFORMATION

Orderable Device	Status (1)	Package Type	Package Drawing	Pins	Package Qty	Eco Plan (2)	Lead/Ball Finish (6)	MSL Peak Temp (3)	Op Temp (°C)	Device Marking (4/5)	Samples
DRV8833CPWP	ACTIVE	HTSSOP	PWP	16	90	Green (RoHS & no Sb/Br)	CU NIPDAU	Level-3-260C-168 HR	-40 to 85	8833C	Samples
DRV8833CPWPR	ACTIVE	HTSSOP	PWP	16	2000	Green (RoHS & no Sb/Br)	CU NIPDAU	Level-3-260C-168 HR	-40 to 85	8833C	Samples
DRV8833CRTER	ACTIVE	WQFN	RTE	16	3000	Green (RoHS & no Sb/Br)	CU NIPDAU	Level-2-260C-1 YEAR	-40 to 85	8833C	Samples
DRV8833CRTET	ACTIVE	WQFN	RTE	16	250	Green (RoHS & no Sb/Br)	CU NIPDAU	Level-2-260C-1 YEAR	-40 to 85	8833C	Samples

(1) The marketing status values are defined as follows:

ACTIVE: Product device recommended for new designs.

LIFEBUY: TI has announced that the device will be discontinued, and a lifetime-buy period is in effect.

NRND: Not recommended for new designs. Device is in production to support existing customers, but TI does not recommend using this part in a new design.

PREVIEW: Device has been announced but is not in production. Samples may or may not be available.

OBSOLETE: TI has discontinued the production of the device.

(2) Eco Plan - The planned eco-friendly classification: Pb-Free (RoHS), Pb-Free (RoHS Exempt), or Green (RoHS & no Sb/Br) - please check <http://www.ti.com/productcontent> for the latest availability information and additional product content details.

TBD: The Pb-Free/Green conversion plan has not been defined.

Pb-Free (RoHS): TI's terms "Lead-Free" or "Pb-Free" mean semiconductor products that are compatible with the current RoHS requirements for all 6 substances, including the requirement that lead not exceed 0.1% by weight in homogeneous materials. Where designed to be soldered at high temperatures, TI Pb-Free products are suitable for use in specified lead-free processes.

Pb-Free (RoHS Exempt): This component has a RoHS exemption for either 1) lead-based flip-chip solder bumps used between the die and package, or 2) lead-based die adhesive used between the die and leadframe. The component is otherwise considered Pb-Free (RoHS compatible) as defined above.

Green (RoHS & no Sb/Br): TI defines "Green" to mean Pb-Free (RoHS compatible), and free of Bromine (Br) and Antimony (Sb) based flame retardants (Br or Sb do not exceed 0.1% by weight in homogeneous material)

(3) MSL, Peak Temp. - The Moisture Sensitivity Level rating according to the JEDEC industry standard classifications, and peak solder temperature.

(4) There may be additional marking, which relates to the logo, the lot trace code information, or the environmental category on the device.

(5) Multiple Device Markings will be inside parentheses. Only one Device Marking contained in parentheses and separated by a "~" will appear on a device. If a line is indented then it is a continuation of the previous line and the two combined represent the entire Device Marking for that device.

(6) Lead/Ball Finish - Orderable Devices may have multiple material finish options. Finish options are separated by a vertical ruled line. Lead/Ball Finish values may wrap to two lines if the finish value exceeds the maximum column width.

Important Information and Disclaimer: The information provided on this page represents TI's knowledge and belief as of the date that it is provided. TI bases its knowledge and belief on information provided by third parties, and makes no representation or warranty as to the accuracy of such information. Efforts are underway to better integrate information from third parties. TI has taken and continues to take reasonable steps to provide representative and accurate information but may not have conducted destructive testing or chemical analysis on incoming materials and chemicals. TI and TI suppliers consider certain information to be proprietary, and thus CAS numbers and other limited information may not be available for release.

In no event shall TI's liability arising out of such information exceed the total purchase price of the TI part(s) at issue in this document sold by TI to Customer on an annual basis.

MECHANICAL DATA

RTE (S-PWQFN-N16)

PLASTIC QUAD FLATPACK NO-LEAD



4205254/D 01/11

- NOTES:
- A. All linear dimensions are in millimeters. Dimensioning and tolerancing per ASME Y14.5M-1994.
 - B. This drawing is subject to change without notice.
 - C. Quad Flatpack, No-leads (QFN) package configuration.
 -  The package thermal pad must be soldered to the board for thermal and mechanical performance. See the Product Data Sheet for details regarding the exposed thermal pad dimensions.
 - E. Falls within JEDEC MO-220.

THERMAL PAD MECHANICAL DATA

RTE (S-PWQFN-N16)

PLASTIC QUAD FLATPACK NO-LEAD

THERMAL INFORMATION

This package incorporates an exposed thermal pad that is designed to be attached directly to an external heatsink. The thermal pad must be soldered directly to the printed circuit board (PCB). After soldering, the PCB can be used as a heatsink. In addition, through the use of thermal vias, the thermal pad can be attached directly to the appropriate copper plane shown in the electrical schematic for the device, or alternatively, can be attached to a special heatsink structure designed into the PCB. This design optimizes the heat transfer from the integrated circuit (IC).

For information on the Quad Flatpack No-Lead (QFN) package and its advantages, refer to Application Report, QFN/SON PCB Attachment, Texas Instruments Literature No. SLUA271. This document is available at www.ti.com.

The exposed thermal pad dimensions for this package are shown in the following illustration.

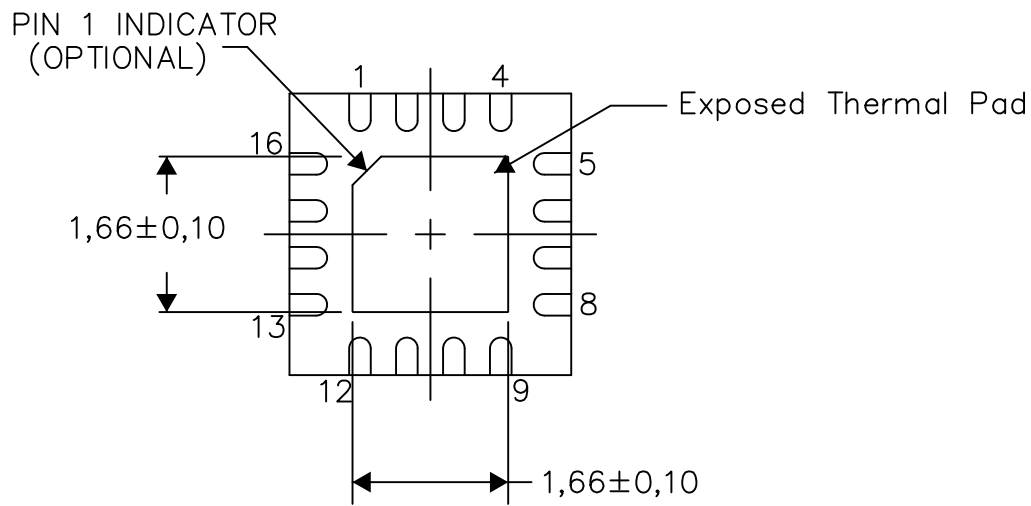

Bottom View

Exposed Thermal Pad Dimensions

4206446-8/U 08/15

NOTE: A. All linear dimensions are in millimeters

RTE (S-PWQFN-N16)

PLASTIC QUAD FLATPACK NO-LEAD

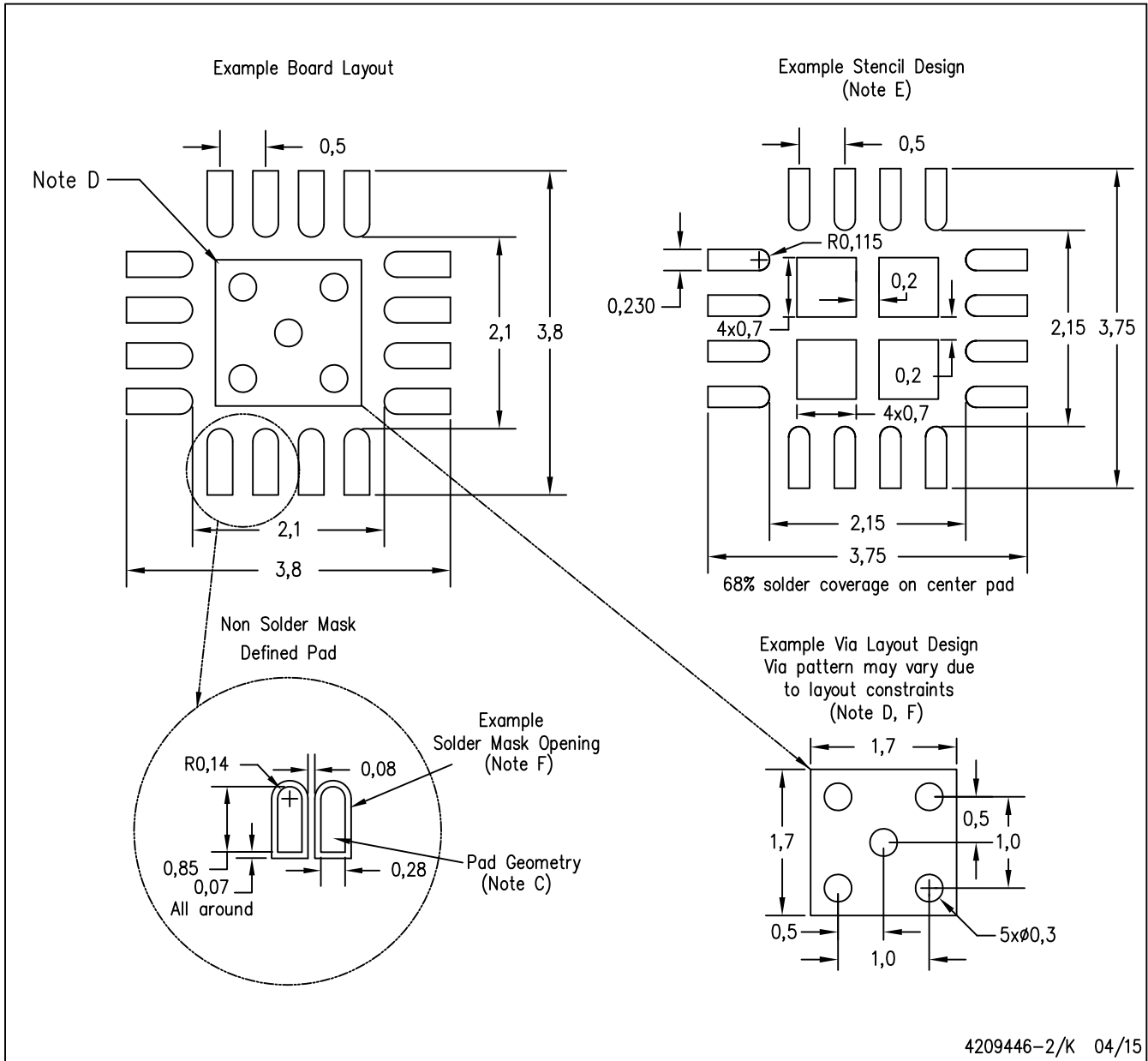

- NOTES:
- A. All linear dimensions are in millimeters.
 - B. This drawing is subject to change without notice.
 - C. Publication IPC-7351 is recommended for alternate designs.
 - D. This package is designed to be soldered to a thermal pad on the board. Refer to Application Note, Quad Flat-Pack Packages, Texas Instruments Literature No. SLUA271, and also the Product Data Sheets for specific thermal information, via requirements, and recommended board layout. These documents are available at www.ti.com <<http://www.ti.com>>.
 - E. Laser cutting apertures with trapezoidal walls and also rounding corners will offer better paste release. Customers should contact their board assembly site for stencil design recommendations. Refer to IPC 7525 for stencil design considerations.
 - F. Customers should contact their board fabrication site for minimum solder mask web tolerances between signal pads.



Images above are just a representation of the package family, actual package may vary.
Refer to the product data sheet for package details.

MECHANICAL DATA

PWP (R-PDSO-G16)

PowerPAD™ PLASTIC SMALL OUTLINE

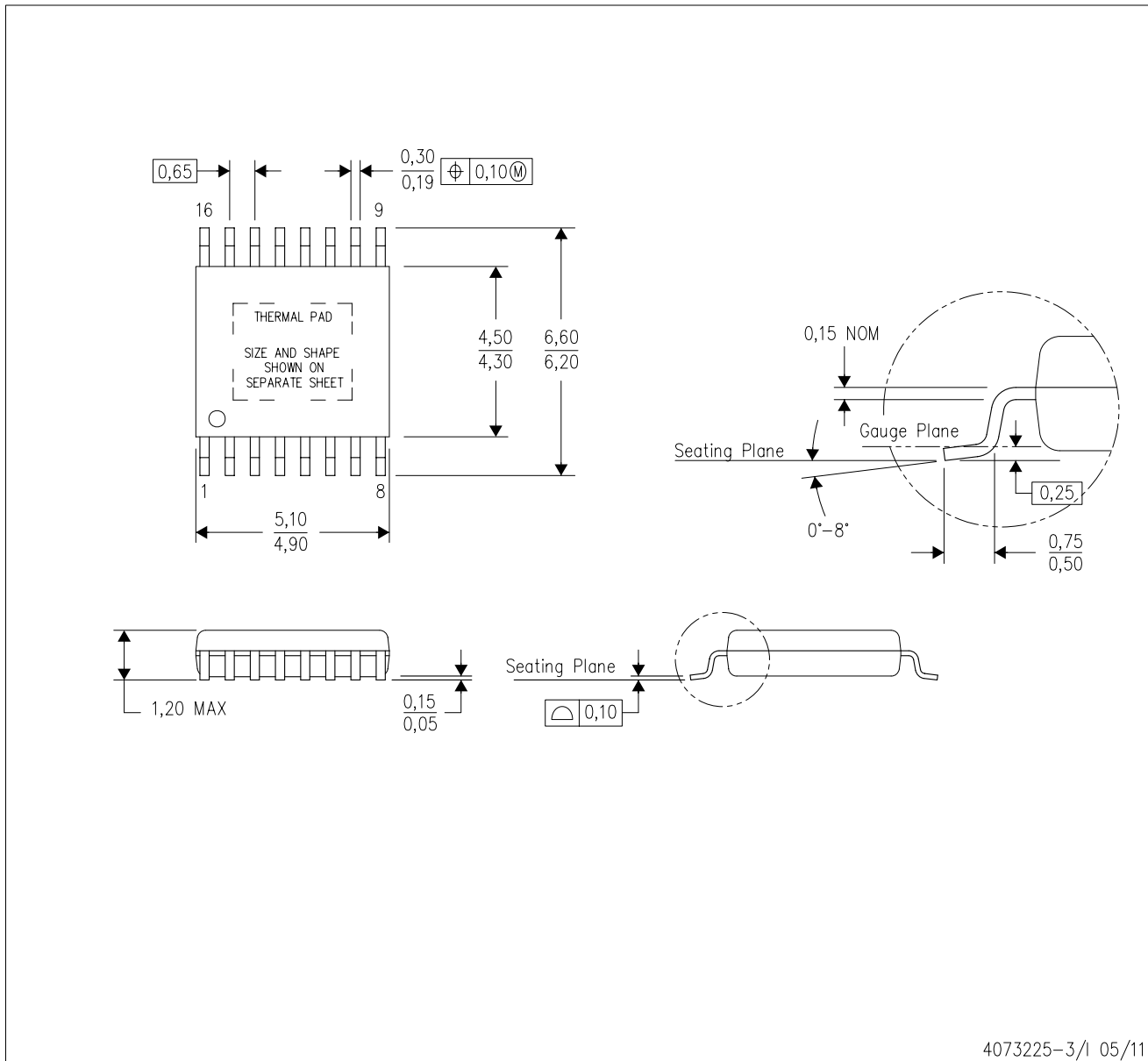

4073225-3/1 05/11

- NOTES:
- All linear dimensions are in millimeters.
 - This drawing is subject to change without notice.
 - Body dimensions do not include mold flash or protrusions. Mold flash and protrusion shall not exceed 0.15 per side.
 - This package is designed to be soldered to a thermal pad on the board. Refer to Technical Brief, PowerPad Thermally Enhanced Package, Texas Instruments Literature No. SLMA002 for information regarding recommended board layout. This document is available at www.ti.com <<http://www.ti.com>>.
 - See the additional figure in the Product Data Sheet for details regarding the exposed thermal pad features and dimensions.
 - Falls within JEDEC MO-153

PowerPAD is a trademark of Texas Instruments.

THERMAL PAD MECHANICAL DATA

PWP (R-PDSO-G16) PowerPAD™ SMALL PLASTIC OUTLINE

THERMAL INFORMATION

This PowerPAD™ package incorporates an exposed thermal pad that is designed to be attached to a printed circuit board (PCB). The thermal pad must be soldered directly to the PCB. After soldering, the PCB can be used as a heatsink. In addition, through the use of thermal vias, the thermal pad can be attached directly to the appropriate copper plane shown in the electrical schematic for the device, or alternatively, can be attached to a special heatsink structure designed into the PCB. This design optimizes the heat transfer from the integrated circuit (IC).

For additional information on the PowerPAD package and how to take advantage of its heat dissipating abilities, refer to Technical Brief, PowerPAD Thermally Enhanced Package, Texas Instruments Literature No. SLMA002 and Application Brief, PowerPAD Made Easy, Texas Instruments Literature No. SLMA004. Both documents are available at www.ti.com.

The exposed thermal pad dimensions for this package are shown in the following illustration.

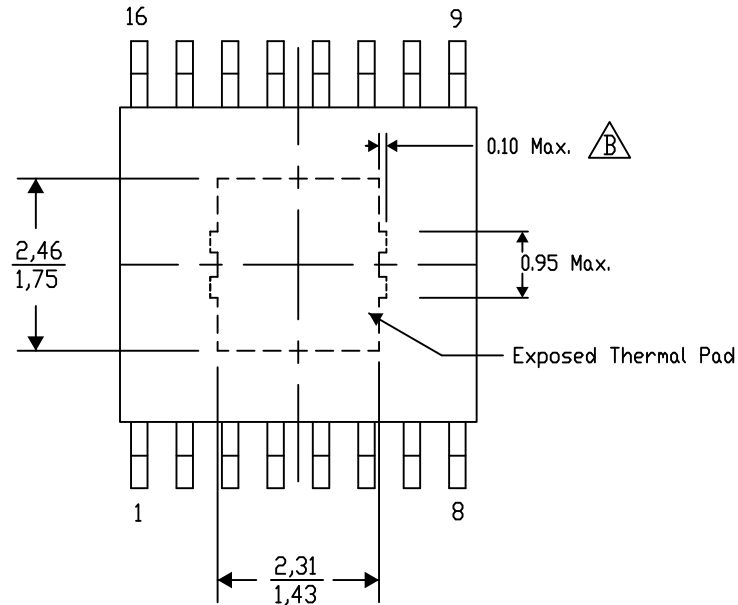

Top View

Exposed Thermal Pad Dimensions

4206332-45/AO 01/16

NOTE: A. All linear dimensions are in millimeters

 Exposed tie strap features may not be present.

PowerPAD is a trademark of Texas Instruments

重要声明

德州仪器 (TI) 公司有权按照最新发布的 JESD46 对其半导体产品和服务进行纠正、增强、改进和其他修改，并不再按最新发布的 JESD48 提供任何产品和服务。买方在下订单前应获取最新的相关信息，并验证这些信息是否完整且是最新的。

TI 公布的半导体产品销售条款 (<http://www.ti.com/sc/docs/stdterms.htm>) 适用于 TI 已认证和批准上市的已封装集成电路产品的销售。另有其他条款可能适用于其他类型 TI 产品及服务的使用或销售。

复制 TI 数据表上 TI 信息的重要部分时，不得变更该等信息，且必须随附所有相关保证、条件、限制和通知，否则不得复制。TI 对该等复制文件不承担任何责任。第三方信息可能受到其它限制条件的制约。在转售 TI 产品或服务时，如果存在对产品或服务参数的虚假陈述，则会失去相关 TI 产品或服务的明示或暗示保证，且构成不公平的、欺诈性商业行为。TI 对此类虚假陈述不承担任何责任。

买方和在系统中整合 TI 产品的其他开发人员（总称“设计人员”）理解并同意，设计人员在设计应用时应自行实施独立的分析、评价和判断，且应全权负责并确保应用的安全性，及设计人员的应用（包括应用中使用的 TI 产品）应符合所有适用的法律法规及其他相关要求。设计人员就自己设计的应用声明，其具备制订和实施下列保障措施所需的一切必要专业知识，能够 (1) 预见故障的危险后果，(2) 监视故障及其后果，以及 (3) 降低可能导致危险的故障几率并采取适当措施。设计人员同意，在使用或分发包含 TI 产品的任何应用前，将彻底测试该等应用和该等应用中所用 TI 产品的功能。

TI 提供技术、应用或其他设计建议、质量特点、可靠性数据或其他服务或信息，包括但不限于与评估模块有关的参考设计和材料（总称“TI 资源”），旨在帮助设计人员开发整合了 TI 产品的应用，如果设计人员（个人，或如果是代表公司，则为设计人员的公司）以任何方式下载、访问或使用任何特定的 TI 资源，即表示其同意仅为该等目标，按照本通知的条款使用任何特定 TI 资源。

TI 所提供的 TI 资源，并未扩大或以其他方式修改 TI 对 TI 产品的公开适用的质保及质保免责声明；也未导致 TI 承担任何额外的义务或责任。TI 有权对其 TI 资源进行纠正、增强、改进和其他修改。除特定 TI 资源的公开文档中明确列出的测试外，TI 未进行任何其他测试。

设计人员只有在开发包含该等 TI 资源所列 TI 产品的应用时，才被授权使用、复制和修改任何相关 TI 资源。但并未依据禁止反言原则或其他法理授予您任何 TI 知识产权的任何其他明示或默示的许可，也未授予您 TI 或第三方的任何技术或知识产权的许可，该等许可包括但不限于任何专利权、版权、屏蔽作品权或与美国 TI 产品或服务的任何整合、机器制作、流程相关的其他知识产权。涉及或参考了第三方产品或服务的信息不构成使用此类产品或服务的许可或与其相关的保证或认可。使用 TI 资源可能需要您向第三方获得对该等第三方专利或其他知识产权的许可。

TI 资源系“按原样”提供。TI 兹免除对资源及其使用作出所有其他明确或默示的保证或陈述，包括但不限于对准确性或完整性、产权保证、无屡发故障保证，以及适销性、适合特定用途和不侵犯任何第三方知识产权的任何默认保证。TI 不负责任何申索，包括但不限于因组合产品所致或与之有关的申索，也不为或对设计人员进行辩护或赔偿，即使该等产品组合已列于 TI 资源或其他地方。对因 TI 资源或其使用引起或与之有关的任何实际的、直接的、特殊的、附带的、间接的、惩罚性的、偶发的、从属或惩戒性损害赔偿，不管 TI 是否获悉可能会产生上述损害赔偿，TI 概不负责。

除 TI 已明确指出特定产品已达到特定行业标准（例如 ISO/TS 16949 和 ISO 26262）的要求外，TI 不对未达到任何该等行业标准要求而承担任何责任。

如果 TI 明确宣称产品有助于功能安全或符合行业功能安全标准，则该等产品旨在帮助客户设计和创作自己的符合相关功能安全标准和要求的的应用。在应用内使用产品的行为本身不会配有安全特性。设计人员必须确保遵守适用于其应用的相关安全要求和标准。设计人员不可将任何 TI 产品用于关乎性命的医疗设备，除非已由各方获得授权的管理人员签署专门的合同对此类应用专门作出规定。关乎性命的医疗设备是指出现故障会导致严重身体伤害或死亡的医疗设备（例如生命保障设备、心脏起搏器、心脏除颤器、人工心脏泵、神经刺激器以及植入设备）。此类设备包括但不限于，美国食品药品监督管理局认定为 III 类设备的设备，以及在美国以外的其他国家或地区认定为同等类别设备的所有医疗设备。

TI 可能明确指定某些产品具备某些特定资格（例如 Q100、军用级或增强型产品）。设计人员同意，其具备一切必要专业知识，可以为自己的应用选择适合的产品，并且正确选择产品的风险由设计人员承担。设计人员单方面负责遵守与该等选择有关的所有法律或监管要求。

设计人员同意向 TI 及其代表全额赔偿因其不遵守本通知条款和条件而引起的任何损害、费用、损失和/或责任。

邮寄地址：上海市浦东新区世纪大道 1568 号中建大厦 32 楼，邮政编码：200122
Copyright © 2017 德州仪器半导体技术（上海）有限公司