



SY7807

1.5A flash LED boost driver for smart phone application Preliminary Specification

General Description

The SY7807 is a high efficiency, 2 MHz frequency synchronous Boost converter with 1.5A constant current drivers for high current white LED. SY7807 could operate in Torch mode or Flash mode. It is an ideal power solution for WLED photo flash applications within small PCB layout dimension and used in Lithium-ion/polymer battery operated products.

Ordering Information

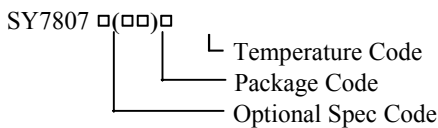

Ordering Number	Package Type	Note
SY7807ADC	TSOT23-6	-----
SY7807DEC	DFN2×2-6	-----

Features

- Input voltage range: 2.7V to 5.5V.
- 2MHz switching frequency to achieve small total solution size.
- Drive up to 1.5A LED flash current
- Drive up to 300mA LED torch current
- Dimming frequency: 20kHz~200kHz
- Timeout function in flash mode
- Independent flash-mode enable and torch-mode enable pins
- Low $R_{DS(ON)}$ of internal FET: 180m ohm for PFET and 200m ohm for NFET.
- LED open/short protection
- Over-voltage protection
- 0.1 μ A shutdown current
- Thermal shutdown.
- -40 to +85 C° Temperature Range
- Pb-free Package: TSOT23-6, DFN2×2-6

Applications

- Smart phone/digital camera LED flash.
- White LED driver.

Typical Applications

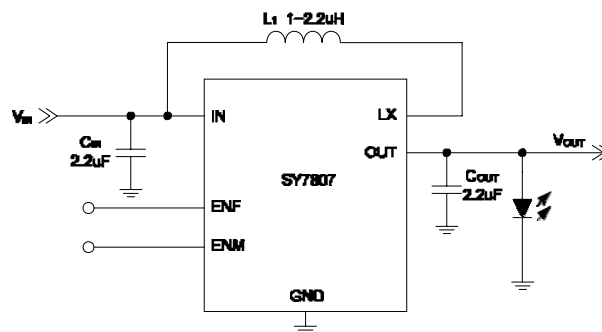

Fig.1 schematic



Electrical Characteristics

($V_{IN} = 3.6V$, $T_A = 25^{\circ}C$ unless otherwise specified)

Parameter	Symbol	Test Conditions	Min	Typ	Max	Unit
Input Voltage Range	V_{IN}		2.7		5.5	V
Quiescent Current	I_Q	ENM='1' or ENF='1', ILED=0			1500	μA
Shutdown Current	I_{SHDN}	ENM='0', ENF='0'		0.1	1	μA
NFET RON	$R_{DS(ON)1}$			200		m Ω
PFET RON	$R_{DS(ON)2}$			180		m Ω
OVP Rising Threshold	OVPth			5		V
OVP Hysteresis	OVP _{hys}			120		mV
Maximum Output Current	I_{MAX}			1.5		A
Flash timeout	$T_{timeout}$	ENF='1'		1.024		S
LED Current Accuracy	ILED _A	750mA flash current	-13		+13	%
		150mA torch current	-11		+11	%
Switching Frequency	F_{SW}			2		MHz
Input Logic Low	V_{IL}				0.4	V
Input Logic High	V_{IH}		1.4		V_{IN}	V
VIN UVLO Rising Threshold	V_{INUVLO}		2.1	2.4	2.68	V
UVLO Hysteresis	UVLO _{HYS}			0.1		V
Thermal Shutdown Temperature	T_{SD}			150		$^{\circ}C$
Thermal Shutdown Hysteresis	T_{HYS}			20		$^{\circ}C$

Note 1: Stresses beyond the “Absolute Maximum Ratings” may cause permanent damage to the device. These are stress ratings only. Functional operation of the device at these or any other conditions beyond those indicated in the operational sections of the specification is not implied. Exposure to absolute maximum rating conditions for extended periods may affect device reliability

Note 2: θ_{JA} is measured in the natural convection at $T_A = 25^{\circ}C$ on a low effective single layer thermal conductivity test board of JEDEC 51-3 thermal measurement standard.

Note 3. The device is not guaranteed to function outside its operating conditions

Function Description

SY7807 is a 2MHz switching frequency boost flash LED driver capable of delivering up to 1.5A current into a single LED.

Enable the Device:

The driver IC will be shut down if both ENF and ENM are low. If ENF is high and ENM is low, the LED current will be ramped up to the flash mode current. If ENM is high whether ENF is high or low, the LED current will be ramped up to the torch mode current.

Boost Mode & LDO Mode:

When ENM or ENF is high level, SY7807 operates in LDO Mode to slowly charge output capacitor firstly. In LDO Mode, Boost converter stops switching and the internal PFET turns on as LDO to adjust the LED output current. If the internal PFET is fully turned on and V_{OUT} is not high enough to provide desired LED current, SY7807 will enter into Boost Mode.

When the Boost input voltage increase and/or the LED current setting value decreases, if the LED current is higher than setting value in Boost mode, SY7807 will quit boost mode and enter into LDO mode again.

Torch Mode:

Torch mode LED current is set a maximum current of 300mA internally.

Flash Mode:

Flash-mode LED current is set a maximum current of 1.5A internally.

PWM Dimming:

When the ENM pin is constantly high, the LED current is regulated to 300mA typically in torch mode. When the ENF pin is constantly high, the LED current is regulated to 1.5A typically in flash mode with a fixed flash time out event.

For additional flexibility, a lower torch mode current and flash mode current than the fixed setting value could be realized by applying a PWM dimming signal at ENM/ENF pin.

Fig.2 shows the internal block diagram of PWM dimming circuit of SY7807. The external PWM signal could be used to adjust the internal LED current reference to adjust LED current.

If the PWM signal is added at ENM pin, the torch LED current will be regulated to be: $300 \times \text{PWM duty cycle (mA)}$.

If the PWM signal is added at ENF pin, the flash LED current will be regulated to be: $1500 \times \text{PWM duty cycle (mA)}$.

It is recommended to apply the PWM signal frequency with 20kHz to 200kHz range.

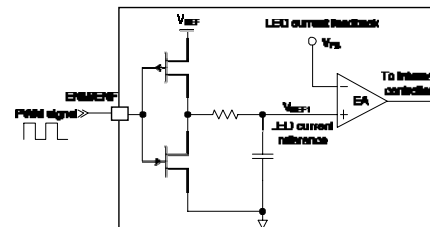

Figure 2 Block Diagram of PWM dimming

LED Short Protection:

If OUT voltage is lower than 2.2V when IC has been enabled (torch or flash mode), the output current will be limited to 100mA.

LED Over Voltage Protection(OVP):

The OVP threshold is typically 5V. Once OUT voltage is higher than OVP threshold, OVP event is triggered, the boost converter stops switching by turning off internal NFET and PFET, then resumes switching after the OUT voltage falls below the OVP threshold by the OVP hysteresis.

Over Temperature Protection:

When the SY7807's junction temperature reaches $+150^{\circ}\text{C}$, the IC will shut down. The IC will not start up again until the junction temperature falls below $+130^{\circ}\text{C}$ or the power input is recycled.

Applications Information

Input Capacitor C_{IN}:

The ripple current through input capacitor is calculated as:

$$I_{CIN_RMS} = \frac{V_{IN} \times (V_{OUT} - V_{IN})}{2\sqrt{3} \times L \times F_{SW} \times V_{OUT}}$$

X5R or X7R ceramic capacitors with greater than 2.2μF capacitance are recommended to handle this ripple current. To minimize the potential noise problem, place this ceramic capacitor to close to the IN pin and GND pin.

Output Capacitor C_{OUT}:

The output capacitor is selected to handle the output ripple noise requirements. This ripple voltage is related to the capacitance and its equivalent series resistance (ESR). For the best performance, it is recommended to use X5R or better grade low ESR ceramic capacitor. The voltage rating of the output capacitor should be higher than the maximum output voltage. The minimum required capacitance can be calculated as:

$$C_{OUT} = \frac{I_{LED} \times (V_{OUT} - V_{IN})}{F_{SW} \times V_{OUT} \times V_{RIPPLE}}$$

V_{ripple} is the peak to peak output ripple. For LED applications, the equivalent resistance of the LED is typically low. The output capacitance should be large enough to attenuate the ripple current through LED. For most applications, a 2.2μF ceramic capacitor is sufficient.

Inductor L:

A 1μH~2.2μH inductor is recommended.(Reference Table 1).The DCR of the inductor and the core loss at the switching frequency must be low enough to achieve the desired high efficiency requirement. The saturation current rating of the inductor must be selected to be greater than the peak inductor current under full load conditions.

Table 1. Recommended Inductor for SY7807

Part Number	L (μH)	DCR (mΩ)	Saturation Current (A)	Dimensions (L×W×H) (mm)
VLS252010HBX-1R0M	1	65	3.57	2.5×2×1

Layout Design:

Proper PCB layout and components placement are critical to the performance of the IC and to prevent noise and electromagnetic interference problems. Following are some rules for the PCB layout:

- 1) The loop of OUT pin, output capacitor and GND pin must be as short as possible
- 2) It is desirable to maximize the PCB copper area connecting to GND pin to achieve the best thermal and noise performance.
- 3) C_{IN} must be close to IN pin and GND pin. The loop area formed by C_{IN} and GND must be minimized.
- 4) The PCB copper area associated with LX pin must be minimized to avoid the potential noise problem.

TSOT23-6 Package outline & PCB layout

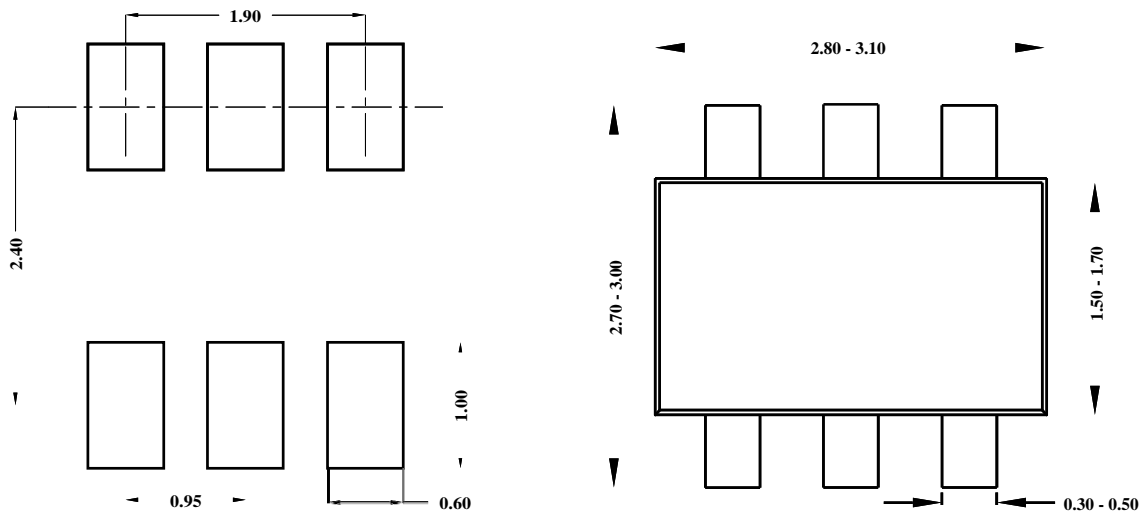

Recommended Pad Layout

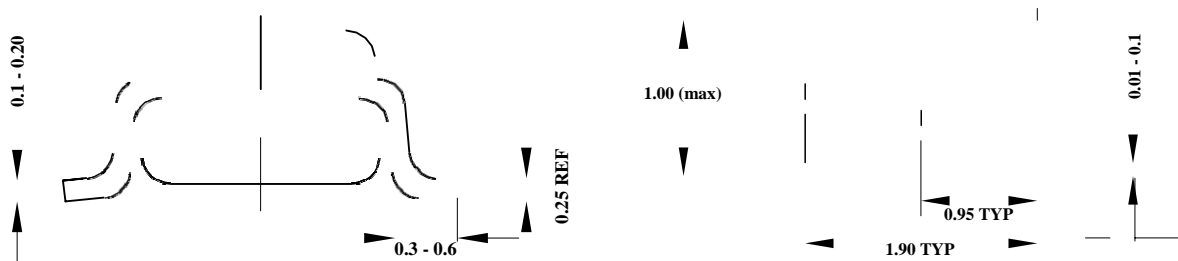

Notes: All dimension in millimeter
 All dimension don't include mold flash & metal burr

DFN2x2-6 Package outline

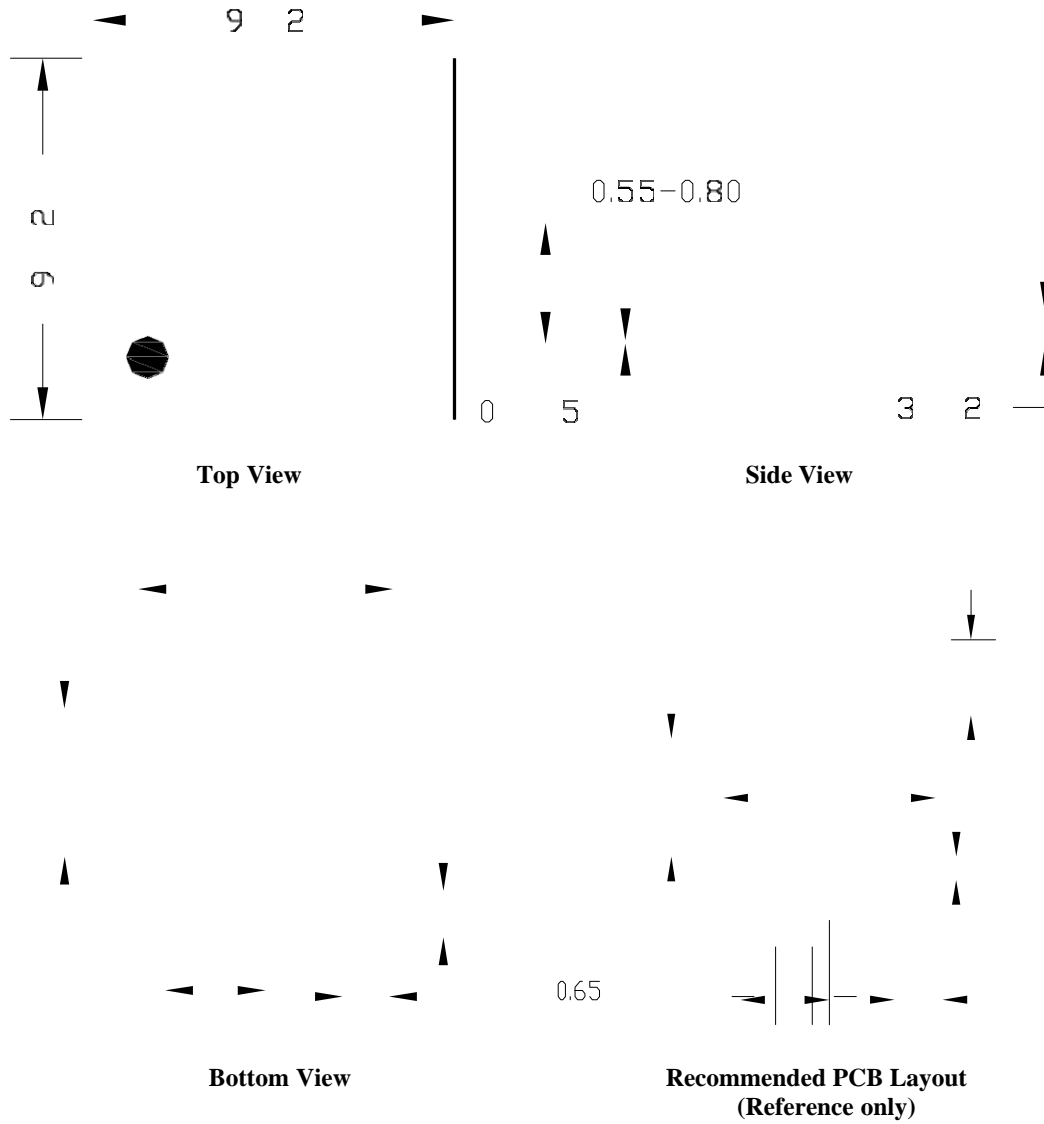

Notes: All dimension in millimeter and exclude mold flash & metal burr.

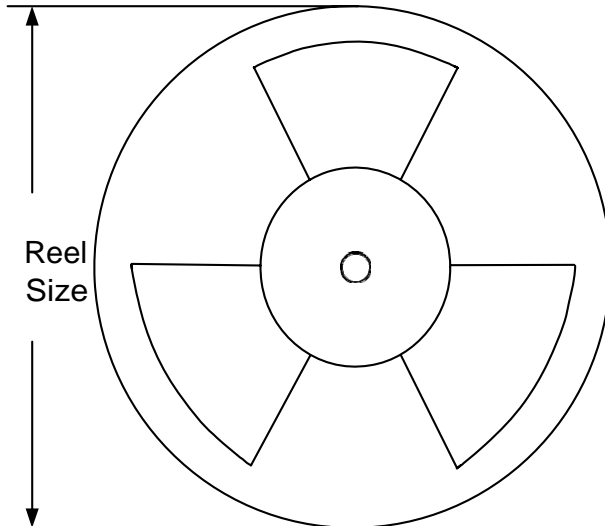
2. Carrier Tape & Reel specification for packages

Package type	Tape width (mm)	Pocket pitch(mm)	Reel size (Inch)	Trailer length(mm)	Leader length (mm)	Qty per reel
TSOT23-6	8	4	7"	400	160	3000
DFN2x2	8	4	7"	400	160	3000

3. Others: NA