

Technical Data Sheet

Photo-link Light Transmitter Unit

Mob:18903054065 QQ2462655096

PLT237/L5 SERIES

Features

- High speed signal transmission (25Mbps NRZ Signal)
- TTL interface compatible
- +3~+5V single power source
- The product itself will remain within RoHS compliant version.

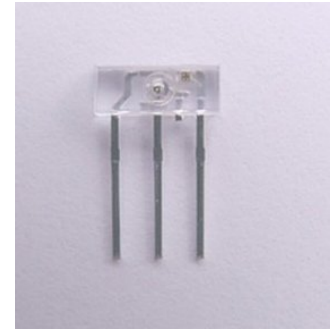

Descriptions Descriptions

The opto-electrical component is assembled with a 660nm AlGaInP LED and a driver IC. It transforms the electrical signal to optical signal and be transmitted by 1mm diameter plastic optical fiber.

The component is operated at +3~+5V and has good performance at low dissipation current, steady light output and efficient light coupling.

Applications

- Digital audio equipment
- CD player
- DVD player

Device Selection Guide

Chip		Operating Voltage (Vcc)	Dissipation Current (mA)		Fiber Coupling Light Output (dBm)		
Material	p(nm)		Typ.	Max.	Min.	Typ.	Max.
AlGaInP	660	+3.0~5.0	5.5	10	-21	---	-14

PLT237/L5 SERIES

Package Dimension:

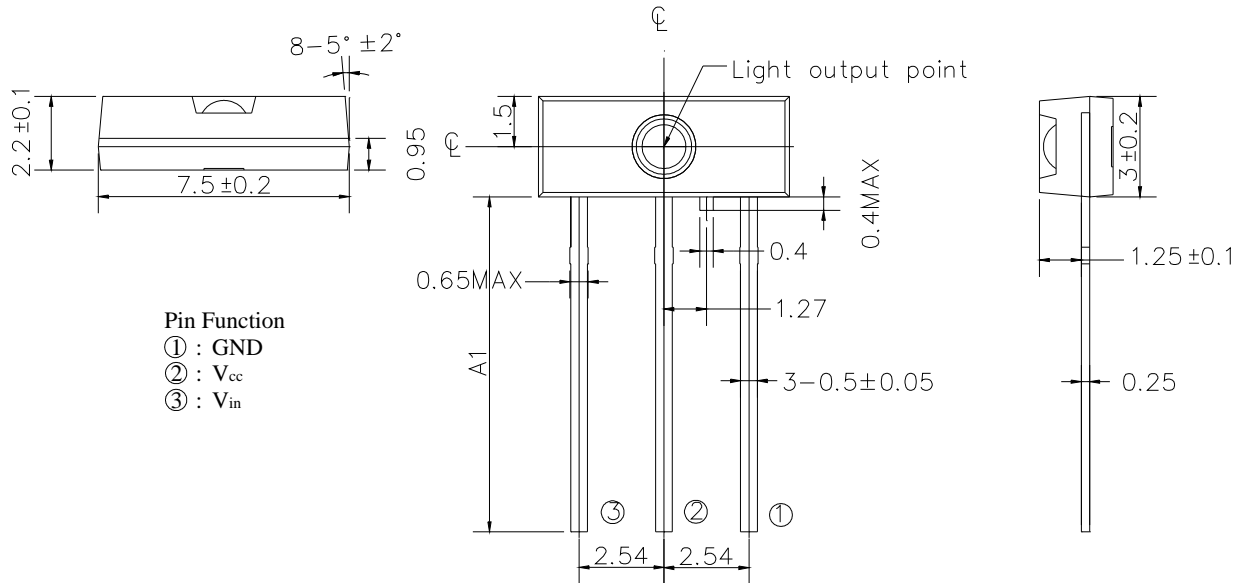

- Notes:**
- 1.All dimensions are in mm.
 - 2.General Tolerance: ± 0.10 mm
 - 3.Device Selection Table:

Device Name	Pin Length A1 (mm)
PLT237/L5	Min 12.00
PLT237/L5/S	8.60 ± 0.25
PLT237/L5/S9	8.00 ± 0.25
PLT237/L5/S17	$15.00 + 1 / - 0$
PLT237/L5/S19	$16.00 + 0.3 / - 0.1$
PLT237/L5/S22	9.00 ± 0.25
PLT237/L5/S23	6.00 ± 0.25
PLT237/L5/S24	11.5 ± 0.5
PLT237/L5/S34	5.9 ± 0.5

Absolute Maximum Ratings(Ta = 25°C)

Parameter	Symbol	Rating	Unit
Supply Voltage	Vcc	-0.5 to 7	V
DC Input Voltage	Vin	-0.5 to Vcc+0.5	V
Storage Temperature	Tstg	-40 to 85	°C
Operating Temperature	Topr	-20 to 70	°C
Soldering Temperature	Tsol	260*	°C
Human Body Model ESD	HBM	3K	V
Machine Model ESD	MM	300	V

* Soldering time ≤ 20 s.

Recommended Operating Conditions

Parameter	Symbol	Conditions	MIN.	TYP.	MAX.	Unit
Power supply voltage	Vcc	-	2.75	-	5.25	V

Electro-Optical Characteristics (Ta=25°C, Vcc=3.0V, 25Mbps)

Parameter	Symbol	Conditions	MIN.	TYP.	MAX.	Unit
Peak Emission Wavelength	λ_p		640	660	680	nm
Transmission Rate		NRZ Code	DC	-	25	Mbps
Fiber Coupling Output Power	Pf	*1	-21	-18	-14	dBm
Dissipation Current	Icc	*1	3	-	10	mA
High Level Input Voltage	V _{IH}		2	-	-	V
Low Level Input Voltage	V _{IL}		-	-	0.8	V
Rise Time	Tr	[1] ; *2 NRZ Code	-	15	20	ns
Fall Time	Tf	V _{FLED} = 2.0V	-	15	20	ns
Low to High Delay Time	t _{pLH}	*2	-	-	100	ns
High to Low Delay Time	t _{pHL}	*2	-	-	100	ns
Pulse Width Distortion	Δtw	*2	-15	-	15	ns
Jitter	Δtj	*2	-	-	15	ns

*All Plastic Optical Fiber (980/1000um)

***Circuit Layout Notice:**

When power is off, it must be cut off together in Vin and Vcc pin.
If it only has Vcc power-off, LED will sure to be no output power.

Vcc	Vin	LED Condition
2.7~5.5V	High	ON
2.7~5.5V	Low	OFF
2.7~5.5V	FLOATING	OFF
FLOATING	0~Vcc	OFF

Measuring Method

***1 Measuring method of optical output coupling fiber and dissipation current**

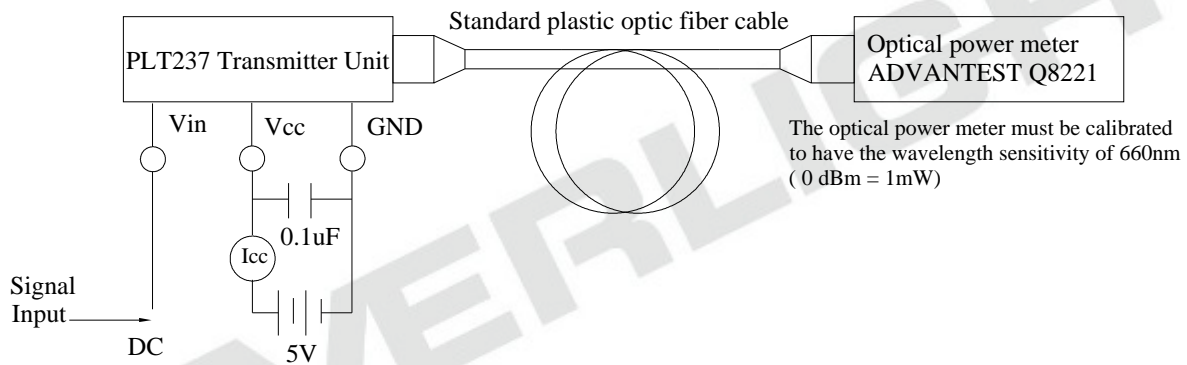

*2 Pulse response measuring method

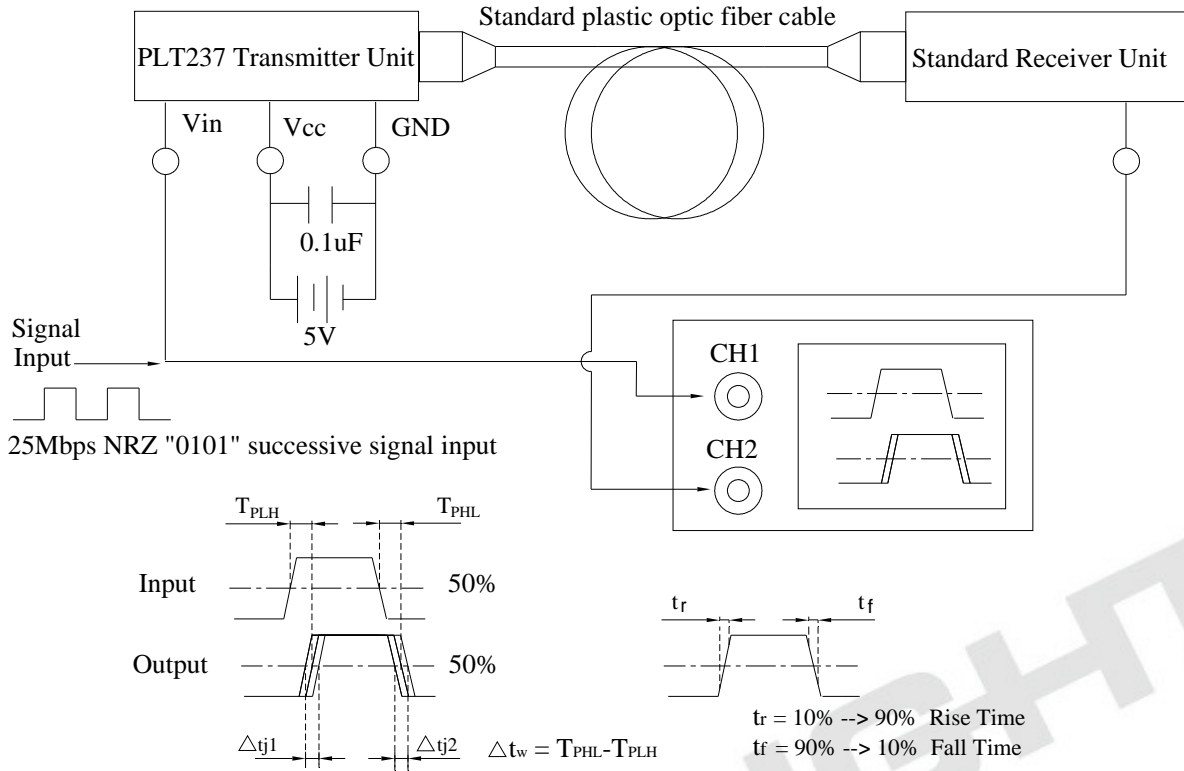

Packing Quantity Specification

1. 500 or 1000 pcs/bag
2. 4 bag/box

Label Form Specification

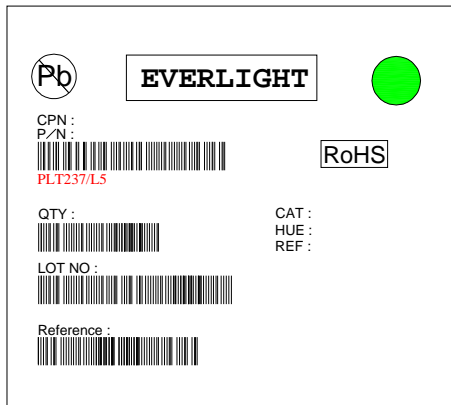

CPN: Customer's Production Number

P/N: Production Number

QTY: Packing Quantity

CAT: De-flash

HUE: IC

REF: Reference

LOT No: Lot Number

Notes

1. Above specification may be changed without notice. EVERLIGHT will reserve authority on material change for above specification.
2. When using this product, please observe the absolute maximum ratings and the instructions for using outlined in these specification sheets. EVERLIGHT assumes no responsibility for any damage resulting from use of the product that does not comply with the absolute maximum ratings and the instructions included in these specification sheets.
3. These specification sheets include materials protected under copyright of EVERLIGHT Corporation. Please don't reproduce or cause anyone to reproduce them without EVERLIGHT's consent.

EVERLIGHT ELECTRONICS CO., LTD.

Office: No 25, Lane 76, Sec 3, Chung Yang Rd,
Tucheng, Taipei 236, Taiwan, R.O.C

Tel: 886-2-2267-2000, 2267-9936

Fax: 886-2267-6244, 2267-6189, 2267-6306

<http://www.everlight.com>