

CDCE813-Q1 Programmable 1-PLL Clock Synthesizer and Jitter Cleaner With 2.5-V and 3.3-V Outputs

1 Features

- Qualified for Automotive Applications
- AEC-Q100 Qualified With the Following Results:
 - Device Temperature Grade 2: –40°C to 105°C Ambient Operating Temperature Range
 - Device HBM ESD Classification Level H2
 - Device CDM ESD Classification Level C6
- In-System Programmability and EEPROM
 - Serial Programmable Volatile Register
 - Nonvolatile EEPROM to Store Customer Settings
- Flexible Input Clocking Concept
 - External Crystal: 8 MHz to 32 MHz
 - Single-Ended LVCMOS up to 160 MHz
- Free Selectable Output Frequency up to 230 MHz
- Low-Noise PLL Core
 - PLL Loop Filter Components Integrated
 - Low Period Jitter (Typical 50 ps)
- 1.8-V Device Power Supply (Core Voltage)
- Separate Output Supply Pins
 - CDCE813-Q1: 3.3 V and 2.5 V
- Flexible Clock Driver
 - Three User-Definable Control Inputs [S0, S1, S2], for Example, SSC Selection, Frequency Switching, Output Enable, or Power Down
 - Generates Highly Accurate Clocks for Video, Audio, USB, IEEE 1394, RFID, Bluetooth®, WLAN, Ethernet, and GPS
 - Generates Common Clock Frequencies Used With TI-DaVinci™, OMAP™, DSPs
 - Programmable SSC Modulation
 - Enables 0-PPM Clock Generation
- Packaged in TSSOP
- Development and Programming Kit for Easy PLL Design and Programming (TI Pro-Clock™)

2 Applications

- Cluster
- Head Unit
- Navigation Systems
- Advanced Driver Assistance Systems (ADAS)

3 Description

The CDCE813-Q1 device is a modular Phase-locked-loop-based (PLL), low-cost, high-performance, programmable clock synthesizers. They generate up to three output clocks from a single input frequency. Each output can be programmed in-system for any clock frequency up to 230 MHz, using the integrated configurable PLL.

The CDCE813-Q1 has separate output supply pins, V_{DDOUT} , providing 2.5 V to 3.3 V.

The input accepts an external crystal or LVCMOS clock signal. A selectable on-chip VCXO allows synchronization of the output frequency to an external control signal.

The PLL supports SSC (spread-spectrum clocking) for better electromagnetic interference (EMI) performance.

Device Information⁽¹⁾

PART NUMBER	PACKAGE	BODY SIZE (NOM)
CDCE813QPWRQ1	TSSOP (14)	5.00 mm x 4.40 mm

(1) For all available packages, see the orderable addendum at the end of the data sheet.

Typical Application Schematic

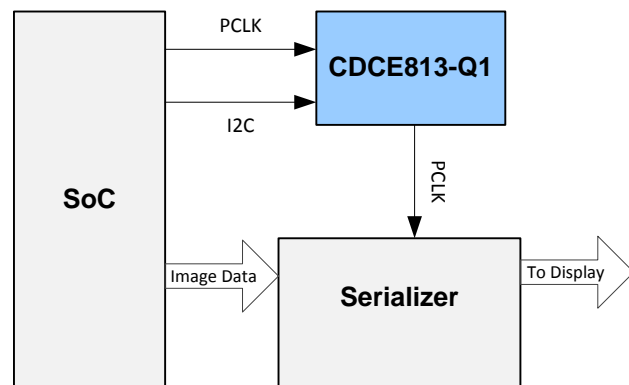

Copyright © 2017, Texas Instruments Incorporated



Table of Contents

1 Features 1 2 Applications 1 3 Description 1 4 Revision History 2 5 Description (continued) 3 6 Pin Configuration and Functions 3 7 Specifications 4 7.1 Absolute Maximum Ratings 4 7.2 ESD Ratings..... 4 7.3 Recommended Operating Conditions 4 7.4 Thermal Information 5 7.5 Electrical Characteristics 5 7.6 Timing Requirements 7 7.7 Typical Characteristics 8 8 Parameter Measurement Information 9 9 Detailed Description 10 9.1 Overview 10 9.2 Functional Block Diagram 10 9.3 Feature Description..... 11	9.4 Device Functional Modes..... 13 9.5 Programming..... 14 9.6 Register Maps 15 10 Application and Implementation 19 10.1 Application Information..... 19 10.2 Typical Application 19 11 Power Supply Recommendations 23 12 Layout 24 12.1 Layout Guidelines 24 12.2 Layout Example 24 13 Device and Documentation Support 25 13.1 Documentation Support 25 13.2 Receiving Notification of Documentation Updates 25 13.3 Community Resources..... 25 13.4 Trademarks 25 13.5 Electrostatic Discharge Caution..... 25 13.6 Glossary 25 14 Mechanical, Packaging, and Orderable Information 25
--	---

4 Revision History

NOTE: Page numbers for previous revisions may differ from page numbers in the current version.

Changes from Revision A (May 2018) to Revision B	Page
• Changed the text in the <i>Default Device Configuration</i> section from: However the outputs are disabled by default and need to be turned on through I2C or with the S0 pin to: However the outputs are disabled by default and need to be turned on through I2C.	12
• Changed the <i>Factory Default Setting</i> table and <i>Default Configuration</i> graphic text to show that the Y1 outputs as 3-state when S0 = 1 or S0 = 0.....	13
• Changed the default value of the SLAVE_ADR 1:0 bits from: 00b to: 01b in the <i>Generic Configuration Register</i> table	16
• Changed the default value of the Y1_ST0 3:2 bits from: 11b to: 01b in the <i>Generic Configuration Register</i> table.....	16
• Changed the default value of the BCOUNT 7:1 bits from: 20h to: 00h in the <i>Generic Configuration Register</i> table	16
• Changed the default value of the Y2Y3_1 bit from: 1b to: 0b in the <i>PLL1 Configuration Register</i> table.....	17

Changes from Original (January 2017) to Revision A	Page
• Changed the <i>Factory Default Setting</i> table and <i>Default Configuration</i> graphic text to show that S0 = 1 means Y1 outputs 3-state and S0 = 0 means Y1 is enabled	13

5 Description (continued)

The device supports nonvolatile EEPROM programming for easy customization of the device to the application. All device settings are programmable through the I2C bus, a 2-wire serial interface.

The CDCE813-Q1 operates in a 1.8-V core environment as well as eliminating the need for additional, independent XTAL oscillators which reduces component count and board size. It operates in a temperature range of –40°C to 105°C.

6 Pin Configuration and Functions

**PW Package
14-Pin TSSOP
Top View**

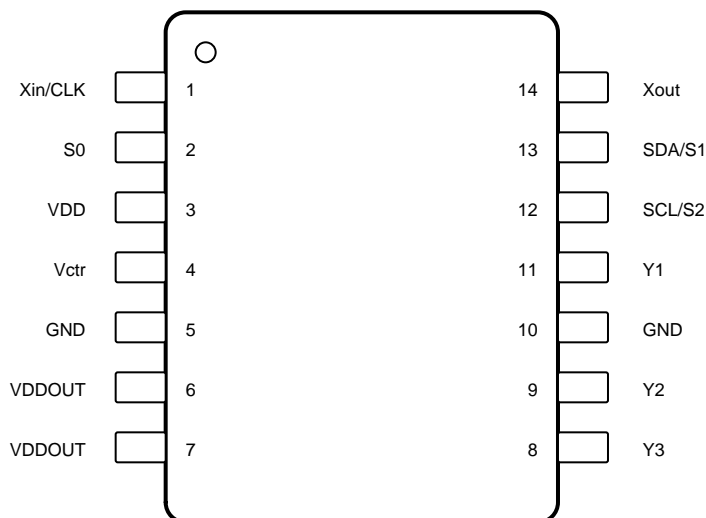

Pin Functions

PIN		TYPE ⁽¹⁾	DESCRIPTION
NAME	NO.		
GND	5, 10	G	Ground
SCL/S2	12	I	SCL: serial clock input LVCMOS (default configuration), 500-kΩ internal pullup; or S2: user-programmable control input, LVCMOS input, 500-kΩ internal pullup
SDA/S1	13	I/O or I	SDA: bidirectional serial data input or output (default configuration), LVCMOS internal pullup; or S1: user-programmable control input, LVCMOS input, 500-kΩ internal pullup
S0	2	I	User-programmable control input S0, LVCMOS input, 500-kΩ internal pullup
V _{ctr}	4	I	VCXO control voltage (leave open or pull up when not used)
V _{DD}	3	P	1.8-V power supply for the device
V _{DDOUT}	6, 7	P	CDCE813-Q1: 3.3-V or 2.5-V supply for all outputs
Xin/CLK	1	I	Crystal oscillator input or LVCMOS clock input (selectable through the I2C bus)
Xout	14	O	Crystal oscillator output (leave open or pull up when not used)
Y1	11	O	LVCMOS output
Y2	9	O	LVCMOS output
Y3	8	O	LVCMOS output

(1) G = Ground, I = Input, O = Output, P = Power

7 Specifications

7.1 Absolute Maximum Ratings

 over operating free-air temperature range (unless otherwise noted)⁽¹⁾

			MIN	MAX	UNIT
V _{DD}	Supply voltage		-0.5	2.5	V
V _{DDOUT}	Output clocks supply voltage	CDCE813-Q1	-0.5	3.6 + 0.5	V
V _I	Input voltage ⁽²⁾⁽³⁾		-0.5	V _{DD} + 0.5	V
V _O	Output voltage ⁽²⁾		-0.5	V _{DDOUT} + 0.5	V
I _I	Input current (V _I < 0, V _I > V _{DD})			20	mA
I _O	Continuous output current			50	mA
T _J	Maximum junction temperature			125	°C
T _{stg}	Storage temperature		-65	150	

- (1) Stresses beyond those listed under *Absolute Maximum Ratings* may cause permanent damage to the device. These are stress ratings only, and functional operation of the device at these or any other conditions beyond those indicated under *Recommended Operating Conditions* is not implied. Exposure to absolute-maximum-rated conditions for extended periods may affect device reliability.
- (2) The input and output negative voltage ratings may be exceeded if the input and output clamp-current ratings are observed.
- (3) SDA and SCL can go up to 3.6 V as stated in the *Recommended Operating Conditions* table.

7.2 ESD Ratings

			VALUE	UNIT
V _(ESD)	Electrostatic discharge	Human-body model (HBM), per AEC Q100-002 ⁽¹⁾	±2000	V
		Charged-device model (CDM), per AEC Q100-011	±1500	

- (1) AEC Q100-002 indicates that HBM stressing shall be in accordance with the ANSI/ESDA/JEDEC JS-001 specification.

7.3 Recommended Operating Conditions

			MIN	NOM	MAX	UNIT
V _{DD}	Device supply voltage		1.7	1.8	1.9	V
V _O	Output Yx supply voltage, V _{DDOUT}	CDCE813-Q1	2.3		3.6	V
V _{IL}	Low-level input voltage, LVCMOS				0.3 × V _{DD}	V
V _{IH}	High-level input voltage, LVCMOS		0.7 × V _{DD}			V
V _{I(thresh)}	Input voltage threshold, LVCMOS			0.5 × V _{DD}		V
V _{I(S)}	Input voltage range, S0		0		1.9	V
	Input voltage range S1, S2, SDA, SCL (V _{I(thresh)} = 0.5 V _{DD})		0		3.6	
V _{I(CLK)}	Input voltage range CLK		0		1.9	V
I _{OH} , I _{OL}	Output current	V _{DDOUT} = 3.3 V			±12	mA
		V _{DDOUT} = 2.5 V			±10	
C _L	Output load, LVCMOS				15	pF
T _A	Operating ambient temperature		-40		105	°C

Recommended Operating Conditions (continued)

		MIN	NOM	MAX	UNIT
CRYSTAL AND VCXO SPECIFICATIONS⁽¹⁾					
f _{Xtal}	Crystal input frequency range (fundamental mode)	8	27	32	MHz
ESR	Effective series resistance			100	Ω
f _{PR}	Pulling range (0 V ≤ V _{ctr} ≤ 1.8 V) ⁽²⁾	±120	±150		ppm
V _{ctr}	Frequency control voltage	0		V _{DD}	V
C ₀ / C ₁	Pullability ratio			220	
C _L	On-chip load capacitance at Xin and Xout	0		20	pF

- (1) For more information about VCXO configuration, and crystal recommendation, see application report [VCXO Application Guideline for CDCE\(L\)9xx Family](#) (SCAA085).
- (2) Pulling range depends on crystal type, on-chip crystal load capacitance, and PCB stray capacitance; pulling range of minimum ±120 ppm applies for crystal listed in the application report [VCXO Application Guideline for CDCE\(L\)9xx Family](#) (SCAA085).

7.4 Thermal Information

THERMAL METRIC ⁽¹⁾⁽²⁾		CDCE813-Q1	UNIT
		PW (TSSOP)	
		14 PINS	
R _{θJA}	Junction-to-ambient thermal resistance	110.6	°C/W
R _{θJC(top)}	Junction-to-case (top) thermal resistance	35.4	°C/W
R _{θJB}	Junction-to-board thermal resistance	53.6	°C/W
ψ _{JT}	Junction-to-top characterization parameter	2.1	°C/W
ψ _{JB}	Junction-to-board characterization parameter	52.8	°C/W
R _{θJC(bot)}	Junction-to-case (bottom) thermal resistance	—	°C/W

- (1) For more information about traditional and new thermal metrics, see the [Semiconductor and IC Package Thermal Metrics](#) application report.
- (2) The package thermal impedance is calculated in accordance with JESD 51 and JEDEC2S2P (high-K board).

7.5 Electrical Characteristics

over recommended operating free-air temperature range (unless otherwise noted)

		TEST CONDITIONS		MIN	TYP ⁽¹⁾	MAX	UNIT
OVERALL PARAMETER							
I _{DD}	Supply current (see Figure 1)	All outputs off, f _{CLK} = 27 MHz, f _{VCO} = 135 MHz, f _{OUT} = 27 MHz	All PLLS on	11			mA
			Per PLL	9			
I _{DD(OUT)}	Supply current (see Figure 2)	No load, all outputs on, f _{OUT} = 27 MHz	V _{DDOUT} = 3.3 V	1.3			mA
I _{DD(PD)}	Power-down current. Every circuit powered down except I2C	f _{IN} = 0 MHz, V _{DD} = 1.9 V		30			μA
V _(PUC)	Supply voltage V _{DD} threshold for power-up control circuit			0.85		1.45	V
f _{VCO}	VCO frequency range of PLL			70		230	MHz
f _{OUT}	LVCOS output frequency	V _{DDOUT} = 3.3 V				230	MHz

- (1) All typical values are at respective nominal V_{DD}.

Electrical Characteristics (continued)

over recommended operating free-air temperature range (unless otherwise noted)

		TEST CONDITIONS	MIN	TYP ⁽¹⁾	MAX	UNIT
LVC MOS PARAMETER						
V _{IK}	LVC MOS input voltage	V _{DD} = 1.7 V, I _I = -18 mA			-1.2	V
I _I	LVC MOS input current	V _I = 0 V or V _{DD} , V _{DD} = 1.9 V			±5	μA
I _{IH}	LVC MOS input current for S0, S1, and S2	V _I = V _{DD} , V _{DD} = 1.9 V			5	μA
I _{IL}	LVC MOS input current for S0, S1, and S2	V _I = 0 V, V _{DD} = 1.9 V			-4	μA
C _I	Input capacitance at X _{in} /CLK	V _{ICLK} = 0 V or V _{DD}		6		pF
	Input capacitance at X _{out}	V _{I_{Xout}} = 0 V or V _{DD}		2		
	Input capacitance at S0, S1, and S2	V _{IS} = 0 V or V _{DD}		3		
CDCE813-Q1, LVC MOS PARAMETER FOR V_{DDOUT} = 3.3-V MODE						
V _{OH}	LVC MOS high-level output voltage	V _{DDOUT} = 3 V, I _{OH} = -0.1 mA	2.9			V
		V _{DDOUT} = 3 V, I _{OH} = -8 mA	2.4			
		V _{DDOUT} = 3 V, I _{OH} = -12 mA	2.2			
V _{OL}	LVC MOS low-level output voltage	V _{DDOUT} = 3 V, I _{OL} = 0.1 mA		0.1		V
		V _{DDOUT} = 3 V, I _{OL} = 8 mA		0.5		
		V _{DDOUT} = 3 V, I _{OL} = 12 mA		0.8		
t _{PLH} , t _{PHL}	Propagation delay	PLL bypass		3.2		ns
		PLL enabled (f _{CLK} = f _{VCO}), 70 MHz ≤ f _{VCO} ≤ 85 MHz	1.6		4.3	
t _r , t _f	Rise and fall time	V _{DDOUT} = 3.3 V (20%–80%)		0.6		ns
t _{jit(cc)}	Cycle-to-cycle jitter ⁽²⁾	1 PLL switching, Y2-to-Y3, 10,000 cycles		50	200	ps
t _{jit(per)}	Peak-to-peak period jitter ⁽²⁾	1 PLL switching, Y2-to-Y3		60	200	ps
t _{sk(o)}	Output skew (see Table 2) ⁽³⁾	f _{OUT} = 50 MHz, Y1-to-Y3			440	ps
odc	Output duty cycle ⁽⁴⁾	f _{VCO} = 100 MHz, Pdiv = 1	45%		55%	
CDCE813-Q1, LVC MOS PARAMETER FOR V_{DDOUT} = 2.5-V MODE						
V _{OH}	LVC MOS high-level output voltage	V _{DDOUT} = 2.3 V, I _{OH} = -0.1 mA	2.2			V
		V _{DDOUT} = 2.3 V, I _{OH} = -6 mA	1.7			
		V _{DDOUT} = 2.3 V, I _{OH} = -10 mA	1.6			
V _{OL}	LVC MOS low-level output voltage	V _{DDOUT} = 2.3 V, I _{OL} = 0.1 mA		0.1		V
		V _{DDOUT} = 2.3 V, I _{OL} = 6 mA		0.5		
		V _{DDOUT} = 2.3 V, I _{OL} = 10 mA		0.7		
t _{PLH} , t _{PHL}	Propagation delay	PLL bypass		3.6		ns
t _r , t _f	Rise and fall time	V _{DDOUT} = 2.5 V (20%–80%)		0.8		ns
t _{jit(cc)}	Cycle-to-cycle jitter ⁽²⁾	1 PLL switching, Y2-to-Y3, 10,000 cycles		50	200	ps
t _{jit(per)}	Peak-to-peak period jitter ⁽²⁾	1 PLL switching, Y2-to-Y3		60	200	ps
t _{sk(o)}	Output skew (see Table 2) ⁽³⁾	f _{OUT} = 50 MHz, Y1-to-Y3			440	ps
odc	Output duty cycle ⁽⁴⁾	f _{VCO} = 100 MHz, Pdiv = 1	45%		55%	

(2) Jitter depends on configuration. Jitter data is for input frequency = 27 MHz, f_{VCO} = 108 MHz, f_{OUT} = 27 MHz (measured at Y2).

(3) The t_{sk(o)} specification is only valid for equal loading of each bank of outputs, and the outputs are generated from the same divider.

(4) odc depends on the output rise and fall time (t_r and t_f); data sampled on the rising edge (t_r)

Electrical Characteristics (continued)

over recommended operating free-air temperature range (unless otherwise noted)

		TEST CONDITIONS	MIN	TYP ⁽¹⁾	MAX	UNIT
I2C PARAMETER						
V _{IK}	SCL and SDA input clamp voltage	V _{DD} = 1.7 V, I _I = –18 mA			–1.2	V
I _{IH}	SCL and SDA input current	V _I = V _{DD} , V _{DD} = 1.9 V			±10	μA
V _{IH}	I2C input high voltage ⁽⁵⁾		0.7 × V _{DD}			V
V _{IL}	I2C input low voltage ⁽⁵⁾				0.3 × V _{DD}	V
V _{OL}	SDA low-level output voltage	I _{OL} = 3 mA, V _{DD} = 1.7 V			0.2 × V _{DD}	V
C _I	SCL-SDA input capacitance	V _I = 0 V or V _{DD}		3	10	pF
EEPROM SPECIFICATION						
EE _{cy}	Programming cycles of EEPROM		100	1000		cycles
EE _{re}	Data retention		10			years

(5) SDA and SCL pins are 3.3-V tolerant.

7.6 Timing Requirements

over recommended ranges of supply voltage, load, and operating free-air temperature

		MIN	NOM	MAX	UNIT
CLK_IN					
f _{CLK}	LVCMOS clock input frequency	PLL bypass mode	0	160	MHz
		PLL mode	8	160	
t _r and t _f	Rise and fall time, CLK signal (20% to 80%)			3	ns
	Duty cycle of CLK at V _{DD} / 2	40%		60%	
I2C (SEE Figure 12)					
f _{SCL}	SCL clock frequency	Standard mode	0	100	kHz
		Fast mode	0	400	
t _{SU(START)}	START setup time (SCL high before SDA low)	Standard mode	4.7		μs
		Fast mode	0.6		
t _{H(START)}	START hold time (SCL low after SDA low)	Standard mode	4		μs
		Fast mode	0.6		
t _{W(SCLL)}	SCL low-pulse duration	Standard mode	4.7		μs
		Fast mode	1.3		
t _{W(SCLH)}	SCL high-pulse duration	Standard mode	4		μs
		Fast mode	0.6		
t _{H(SDA)}	SDA hold time (SDA valid after SCL low)	Standard mode	0	3.45	μs
		Fast mode	0	0.9	
t _{SU(SDA)}	SDA setup time	Standard mode	250		ns
		Fast mode	100		
t _r	SCL-SDA input rise time	Standard mode		1000	ns
		Fast mode		300	
t _f	SCL-SDA input fall time			300	ns
t _{SU(STOP)}	STOP setup time	Standard mode	4		μs
		Fast mode	0.6		
t _{BUS}	Bus free time between a STOP and START condition	Standard mode	4.7		μs
		Fast mode	1.3		

CDCE813-Q1

SNAS705B – JANUARY 2017 – REVISED MAY 2018

www.ti.com

7.7 Typical Characteristics

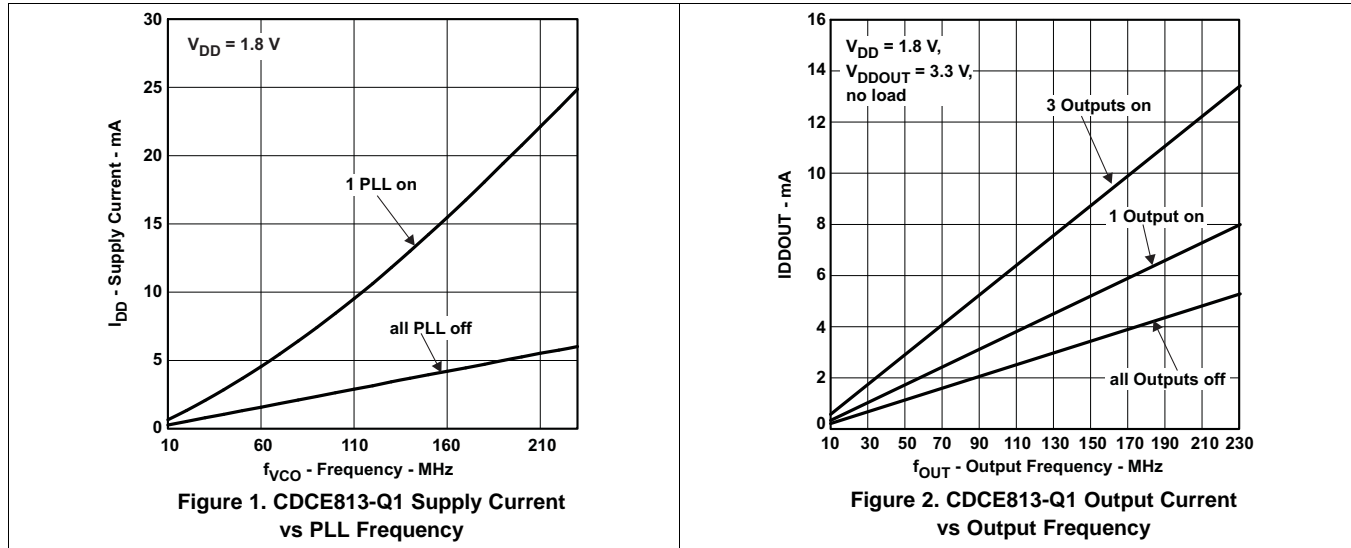

8 Parameter Measurement Information

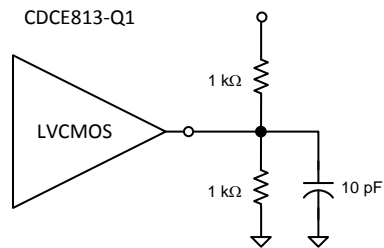

Copyright © 2017, Texas Instruments Incorporated

Figure 3. Test Load

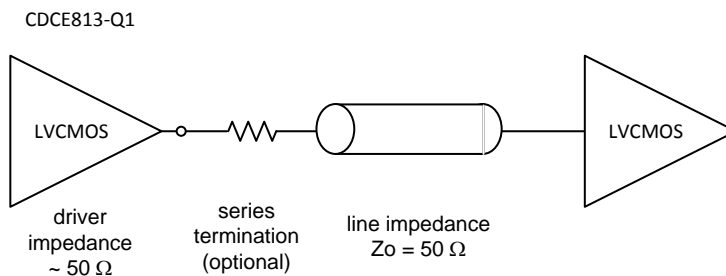

Copyright © 2017, Texas Instruments Incorporated

Figure 4. Test Load for 50-Ω Board Environment

9 Detailed Description

9.1 Overview

The CDCExxx-Q1 devices are modular PLL-based, low-cost, high-performance, programmable clock synthesizers, multipliers, and dividers. They generate up to three output clocks from a single input frequency. Each output can be programmed in-system for any clock frequency up to 230 MHz, using the integrated configurable PLL.

The CDCE813-Q1 device has separate output supply pins, V_{DDOUT} , with output of 2.5 V to 3.3 V.

The input accepts an external crystal or LVCMOS clock signal. If an external crystal is used, an on-chip load capacitor is adequate for most applications. The value of the load capacitor is programmable from 0 pF to 20 pF. Additionally, a selectable on-chip VCXO allows synchronization of the output frequency to an external control signal, that is, the PWM signal.

The deep M / N divider ratio allows the generation of zero-ppm audio-video, networking (WLAN, Bluetooth, Ethernet, GPS) or interface (USB, IEEE1394, memory stick) clocks from, for example, a 27-MHz reference input frequency.

The PLL supports spread-spectrum clocking (SSC). SSC can be center-spread or down-spread clocking, which is a common technique to reduce electromagnetic interference (EMI).

Based on the PLL frequency and the divider settings, the internal loop filter components are automatically adjusted to achieve high stability and optimized jitter transfer characteristics.

The device supports nonvolatile EEPROM programming for easy customization of the device to the application. It is preset to a factory default configuration (see [Default Device Configuration](#)). It can be reprogrammed to a different application configuration before PCB assembly, or reprogrammed by in-system programming. All device settings are programmable through the SDA-SCL bus, a 2-wire serial interface.

Three programmable control inputs, S0, S1, and S2, can be used to select different frequencies, change SSC setting for lowering EMI, or control other features like outputs disable to low, outputs in Hi-Z state, power down, PLL bypass, and so forth).

The CDCE813-Q1 core operates in a 1.8-V environment. It operates in a temperature range of -40°C to 105°C .

9.2 Functional Block Diagram

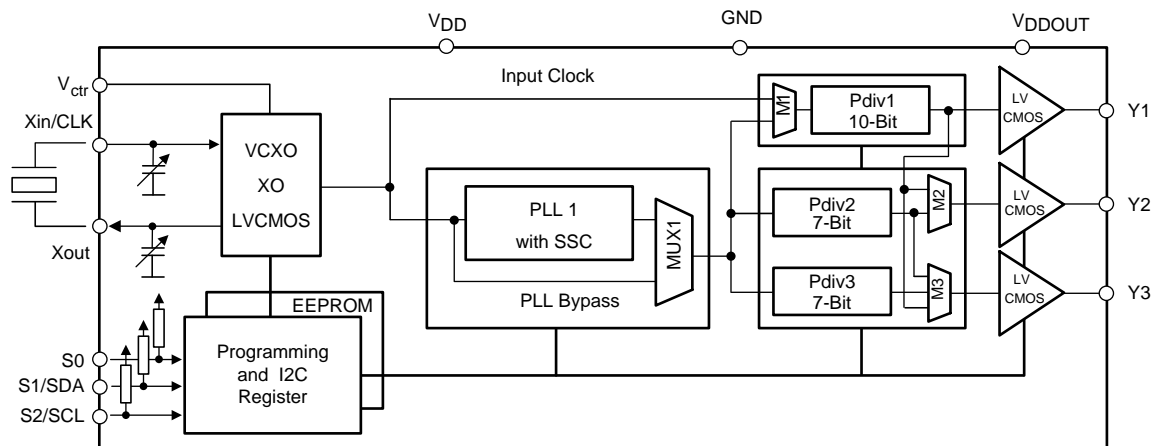

Copyright © 2017, Texas Instruments Incorporated

9.3 Feature Description

9.3.1 Control Terminal Configuration

The CDCE813-Q1 device has three user-definable control terminals (S0, S1, and S2), which allow external control of device settings. They can be programmed to any of the following functions:

- Spread-spectrum clocking selection → spread type and spread amount selection
- Frequency selection → switching between any of two user-defined frequencies
- Output state selection → output configuration and power-down control

The user can predefine up to eight different control settings. [Table 1](#) and [Table 2](#) explain these settings.

Table 1. Control Terminal Definition

EXTERNAL CONTROL BITS	PLL1 SETTING			Y1 SETTING
Control function	PLL frequency selection	SSC selection	Output Y2 and Y3 selection	Output Y1 and power-down selection

Table 2. PLL1 Setting ⁽¹⁾

SSCx [3 BITS]			CENTER	DOWN
SSC SELECTION (CENTER AND DOWN)				
0	0	0	0% (off)	0% (off)
0	0	1	±0.25%	–0.25%
0	1	0	±0.5%	–0.5%
0	1	1	±0.75%	–0.75%
1	0	0	±1.0%	–1.0%
1	0	1	±1.25%	–1.25%
1	1	0	±1.5%	–1.5%
1	1	1	±2.0%	–2.0%

(1) Center and down-spread, Frequency0, Frequency1, State0, and State1 are user-definable in PLL1 configuration register.

Table 3. PLL1 Setting, Frequency Selection ⁽¹⁾

FSx	FUNCTION
0	Frequency 0
1	Frequency 1

(1) Frequency0 and Frequency1 can be any frequency within the specified f_{VCO} range.

Table 4. PLL1 Setting, Output Selection (Y2, Y3) ⁽¹⁾

Y2, Y3	FUNCTION
0	State 0
1	State 1

(1) State0 or State1 selection is valid for both outputs of the corresponding PLL module and can be power down, Hi-Z state, low, or active.

Table 5. Y1 Setting ⁽¹⁾

Y1	FUNCTION
0	State 0
1	State 1

(1) State0 and State1 are user definable in the generic configuration register and can be power down, Hi-Z state, low, or active.

The S1/SDA and S2/SCL pins of the CDCE813-Q1 device are dual-function pins. In the default configuration, they are defined as SDA and SCL for the serial programming interface. They can be programmed as control pins (S1 and S2) by setting the appropriate bits in the EEPROM.

NOTE

Changes to the control register (Bit [6] of byte 02h) have no effect until they are written into the EEPROM.

Once they are set as control pins, the serial programming interface is no longer available. However, if V_{DDOUT} is forced to GND, the two control pins, S1 and S2, temporally act as serial programming pins (SDA and SCL).

S0 is *not* a multi-use pin; it is a control pin only.

9.3.2 Default Device Configuration

The internal EEPROM of the CDCE813-Q1 device is pre-configured with a factory default configuration as shown in Figure 5 (the input frequency is routed through PLL1 to the outputs as a default). This mode can be used to clean the jitter of an incoming clock signal. However the outputs are disabled by default and need to be turned on through I2C.

The default setting appears either after power is supplied or after a power-down – power-up sequence until it is reprogrammed by the user to a different application configuration. A new register setting is programmed through the serial I2C interface.

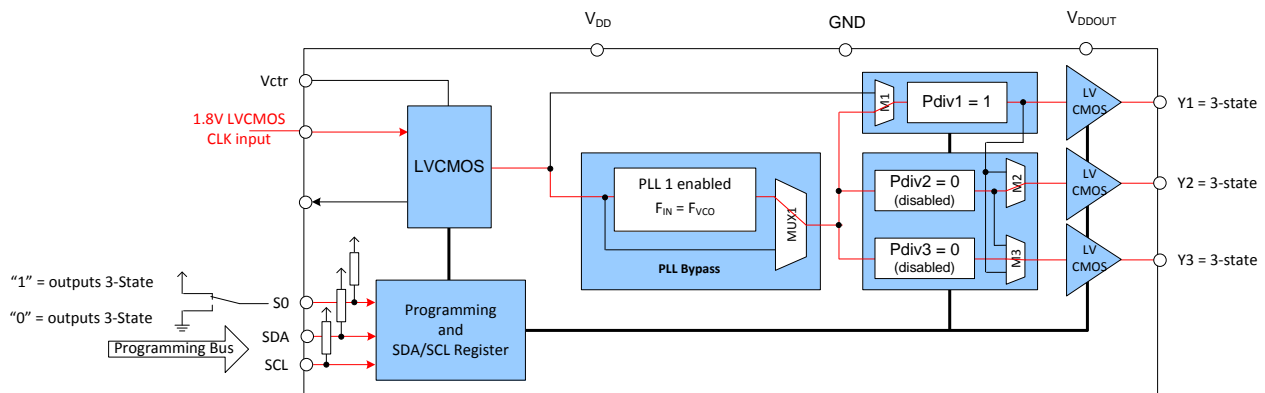

Figure 5. Default Configuration

Table 6 shows the factory default setting for the Control Terminal Register.

NOTE

Even though eight different register settings are possible, in the default configuration, only the first two settings (0 and 1) can be selected with S0, as S1 and S2 are configured as programming pins in default mode.

Table 6. Factory Default Setting for Control Terminal Register ⁽¹⁾

EXTERNAL CONTROL PINS			Y1	PLL1 SETTINGS		
			OUTPUT SELECTION	FREQUENCY SELECTION	SSC SELECTION	OUTPUT SELECTION
S2	S1	S0	Y1	FS1	SSC1	Y2Y3
SCL (I ² C)	SDA (I ² C)	0	3-state	f _{VCO1_0}	Off	3-state
SCL (I ² C)	SDA (I ² C)	1	3-state	f _{VCO1_0}	Off	3-state

(1) In default mode or when programmed respectively, S1 and S2 act as serial programming interface, I²C. They do not have any control-pin function but they are internally interpreted as if S1 = 0 and S2 = 0. S0, however, is a control pin, which in the default mode switches all outputs ON or OFF (as previously predefined).

9.3.3 I²C Serial Interface

The CDCE813-Q1 device operates as a slave device on the 2-wire serial I²C bus compatible with the popular SMBus or I²C specification. It operates in the standard-mode transfer (up to 100 kbps) and fast-mode transfer (up to 400 kbps) and supports 7-bit addressing.

The S1/SDA and S2/SCL pins of the CDCE813-Q1 device are dual-function pins. In the default configuration, they are used as the I²C serial programming interface. They can be reprogrammed as general-purpose control pins, S1 and S2, by changing the corresponding EEPROM setting, byte 02h, bit [6].

9.3.4 Data Protocol

The device supports *Byte Write and Byte Read* and *Block Write and Block Read* operations.

For *Byte Write/Read* operations, the system controller can individually access addressed bytes.

For *Block Write/Read* operations, the bytes are accessed in sequential order from lowest to highest byte (with most-significant bit first) with the ability to stop after any complete byte has been transferred. The numbers of bytes read out are defined by Byte Count in the generic configuration register. At the *Block Read* instruction, all bytes defined in Byte Count must be read out to finish the read cycle correctly.

Once a byte has been sent, it is written into the internal register and is effective immediately. This applies to each transferred byte, regardless of whether this is a *Byte Write* or a *Block Write* sequence.

If the EEPROM write cycle is initiated, the internal SDA registers are written into the EEPROM. During this write cycle, data is not accepted at the I²C bus until the write cycle is completed. However, data can be read out during the programming sequence (*Byte Read* or *Block Read*). The programming status can be monitored by *EEPIP*, byte 01h–bit 6.

The offset of the indexed byte is encoded in the command code, as described in [Table 7](#).

Table 7. Slave Receiver Address (7 Bits)

DEVICE	A6	A5	A4	A3	A2	A1 ⁽¹⁾	A0 ⁽¹⁾	R/W
CDCE813-Q1	1	1	0	0	1	0	1	1/0
CDCEx925	1	1	0	0	1	0	0	1/0
CDCEx937	1	1	0	1	1	0	1	1/0
CDCEx949	1	1	0	1	1	0	0	1/0

(1) Address bits A0 and A1 are programmable through the I²C bus (byte 01, bits [1:0]). This allows addressing up to 4 devices connected to the same I²C bus. The least-significant bit of the address byte designates a write or read operation.

9.4 Device Functional Modes

9.4.1 SDA and SCL Hardware Interface

[Figure 6](#) shows how the CDCE813-Q1 clock synthesizer is connected to the I²C serial interface bus. Multiple devices can be connected to the bus, but it may be necessary to reduce the speed (400 kHz is the maximum) if many devices are connected.

Device Functional Modes (continued)

Note that the pullup resistors (R_p) depend on the supply voltage, bus capacitance, and number of connected devices. The recommended pullup value is 4.7 k Ω . The resistor must meet the minimum sink current of 3 mA at $V_{OLmax} = 0.4$ V for the output stages (for more details see the SMBus or I²C Bus specifications in the [Timing Requirements](#) table).

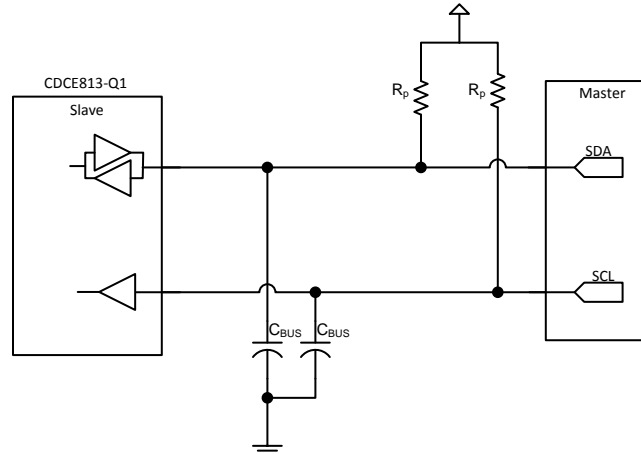

Copyright © 2017, Texas Instruments Incorporated

Figure 6. I2C Hardware Interface

9.5 Programming

Table 8. Command Code Definition

BIT	DESCRIPTION
7	0 = Block Read or Block Write operation 1 = Byte Read or Byte Write operation
(6:0)	Byte offset for Byte Read, Block Read, Byte Write, and Block Write operations

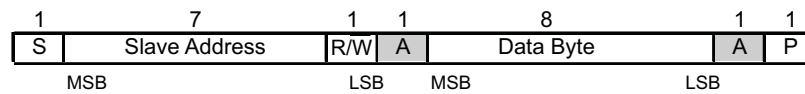

- S** Start Condition
- Sr** Repeated Start Condition
- R/W** 1 = Read (Rd) From CDCE9xx Device; 0 = Write (Wr) to CDCE9xxx
- A** Acknowledge (ACK = 0 and NACK =1)
- P** Stop Condition
- Master-to-Slave Transmission
- Slave-to-Master Transmission

Figure 7. Generic Programming Sequence



Figure 8. Byte Write Protocol

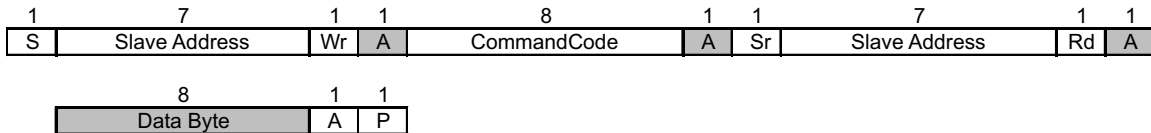
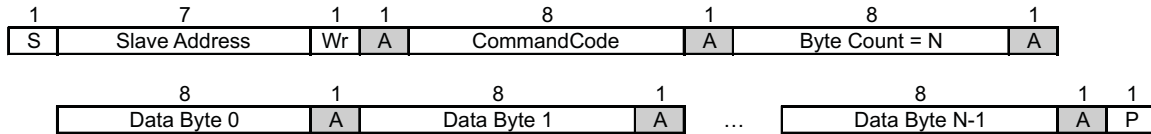

Figure 9. Byte Read Protocol



- (1) Data byte 0 bits [7:0] is reserved for Revision Code and Vendor Identification. Also, it is used for internal test purpose and should not be overwritten.

Figure 10. Block Write Protocol

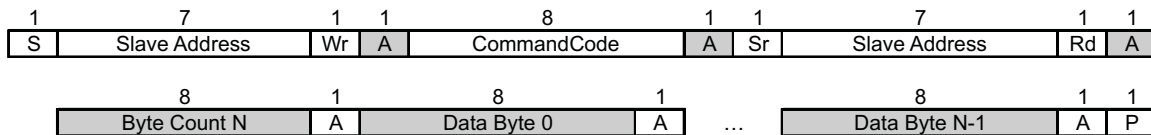

Figure 11. Block Read Protocol

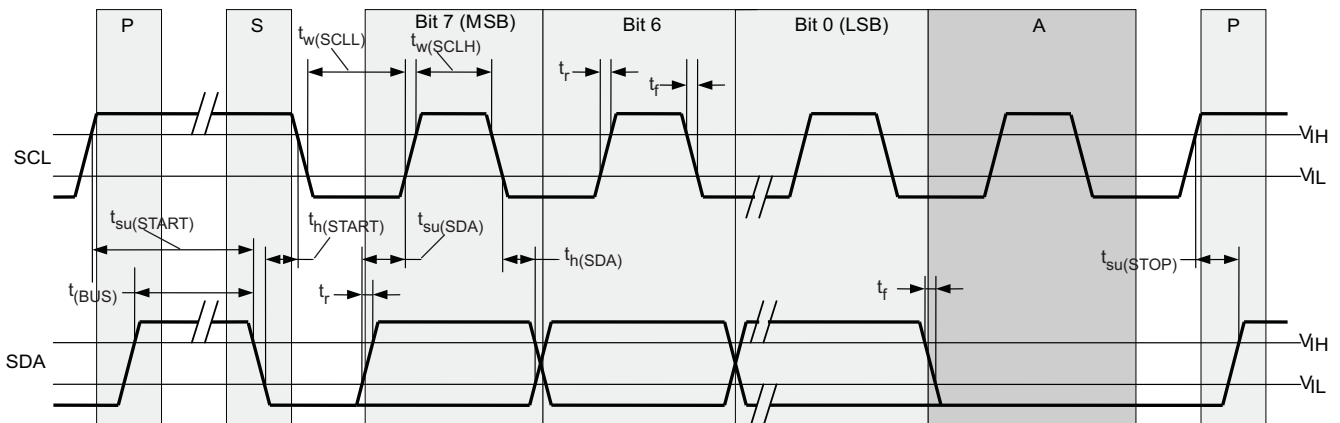

Figure 12. Timing Diagram for I2C Serial Control Interface

9.6 Register Maps

9.6.1 I2C Configuration Registers

The clock input, control pins, PLLs, and output stages are user configurable. The following tables and explanations describe the programmable functions of the CDCE813-Q1 device. All settings can be manually written into the device through the I2C bus or easily programmed by using the TI Pro-Clock™ software. TI Pro-Clock™ software allows the user to make all settings quickly, and automatically calculates the values for optimized performance at lowest jitter.

Table 9. I2C Registers

ADDRESS OFFSET	REGISTER DESCRIPTION	TABLE
00h	Generic configuration register	Table 11
10h	PLL1 configuration register	Table 12

The grey-highlighted bits, described in the configuration register tables in the following pages, belong to the control terminal register. The user can predefine up to eight different control settings. These settings then can be selected by the external control pins, S0, S1, and S2. See the [Control Terminal Configuration](#) section.

Table 10. Configuration Register, External Control Terminals

	EXTERNAL CONTROL PINS			Y1	PLL1 SETTINGS		
	S2	S1	S0	OUTPUT SELECTION	FREQUENCY SELECTION	SSC SELECTION	OUTPUT SELECTION
	Y1	FS1	SSC1	Y2Y3			
0	0	0	0	Y1_0	FS1_0	SSC1_0	Y2Y3_0
1	0	0	1	Y1_1	FS1_1	SSC1_1	Y2Y3_1
2	0	1	0	Y1_2	FS1_2	SSC1_2	Y2Y3_2
3	0	1	1	Y1_3	FS1_3	SSC1_3	Y2Y3_3
4	1	0	0	Y1_4	FS1_4	SSC1_4	Y2Y3_4
5	1	0	1	Y1_5	FS1_5	SSC1_5	Y2Y3_5
6	1	1	0	Y1_6	FS1_6	SSC1_6	Y2Y3_6
7	1	1	1	Y1_7	FS1_7	SSC1_7	Y2Y3_7
	Address offset ⁽¹⁾			04h	13h	10h–12h	15h

(1) Address offset refers to the byte address in the configuration register in [Table 11](#) and [Table 12](#).

Table 11. Generic Configuration Register

OFFSET ⁽¹⁾	BIT ⁽²⁾	ACRONYM	DEFAULT ⁽³⁾	DESCRIPTION
00h	7	E_EL	1b	Device identification (read-only): 1 is CDCE813-Q1 (3.3 Vout)
	6:4	RID	Xb	Revision identification number (read-only)
	3:0	VID	1h	Vendor identification number (read-only)
01h	7	—	0b	Reserved – always write 0
	6	EEPIP	0b	EEPROM programming Status: ⁽⁴⁾ (read-only) 0 – EEPROM programming is completed. 1 – EEPROM is in programming mode.
	5	EELOCK	0b	Permanently lock EEPROM data ⁽⁵⁾ 0 – EEPROM is not locked. 1 – EEPROM is permanently locked.
	4	PWDN	0b	Device power down (overwrites S0, S1, and S2 settings; configuration register settings are unchanged) Note: PWDN cannot be set to 1 in the EEPROM. 0 – Device active (PLL1 and all outputs are enabled) 1 – Device power down (PLL1 in power down and all outputs in Hi-Z state)
	3:2	INCLK	10b	Input clock selection: 00 – Xtal 01 – VCXO 10 – LVCMOS 11 – Reserved
	1:0	SLAVE_ADR	01b	Address bits A0 and A1 of the slave receiver address
02h	7	M1	1b	Clock source selection for output Y1: 0 – Input clock 1 – PLL1 clock
	6	SPICON	0b	Operation mode selection for pins 12 and 13 ⁽⁶⁾ 0 – Serial programming interface SDA (pin 13) and SCL (pin 12) 1 – Control pins S1 (pin 13) and S2 (pin 12)
	5:4	Y1_ST1	01b	Y1-State0/1 definition
	3:2	Y1_ST0	01b	00 – Device power down (all PLLs in power down and all outputs in Hi-Z state) 01 – Y1 disabled to low 10 – Y1 disabled to low 11 – Y1 enabled
03h	7:0	Pdiv1 [7:0]	001h	10-bit Y1-output-divider Pdiv1: 0 – Divider reset and stand-by 1 to 1023 – Divider value

- (1) Writing data beyond 20h may affect device function.
- (2) All data transferred with the MSB first
- (3) Unless customer-specific setting
- (4) During EEPROM programming, no data is allowed to be sent to the device through the I2C bus until the programming sequence is completed. Data, however, can be read out during the programming sequence (*Byte Read* or *Block Read*).
- (5) If this bit is set to high in the EEPROM, the actual data in the EEPROM is permanently locked. No further programming is possible. Data, however can still be written through the I2C bus to the internal register to change device function on the fly, but new data can no longer be saved to the EEPROM. EELOCK is effective only if written into the EEPROM.
- (6) Selection of *control pins* is effective only if written into the EEPROM. Once written into the EEPROM, the serial programming pins are no longer available. However, if V_{DDOUT} is forced to GND, the two control pins, S1 and S2, temporarily act as serial programming pins (SDA-SCL), and the two slave receiver address bits are reset to A0 = 0 and A1 = 0.

Table 11. Generic Configuration Register (continued)

OFFSET ⁽¹⁾	BIT ⁽²⁾	ACRONYM	DEFAULT ⁽³⁾	DESCRIPTION
04h	7	Y1_7	0b	Y1_x State selection ⁽⁷⁾ 0 – State0 (predefined by Y1_ST0) 1 – State1 (predefined by Y1_ST1)
	6	Y1_6	0b	
	5	Y1_5	0b	
	4	Y1_4	0b	
	3	Y1_3	0b	
	2	Y1_2	0b	
	1	Y1_1	0b	
	0	Y1_0	0b	
05h	7:3	XCSEL	00h	Crystal load capacitor selection ⁽⁸⁾ 00h – 0 pF 01h – 1 pF 02h – 2 pF :14h to 1Fh – 20 pF
	2:0		0b	Reserved – do not write other than 0
06h	7:1	BCOUNT	00h	7-bit byte count (defines the number of bytes which will be sent from this device at the next <i>Block Read</i> transfer); all bytes must be read out to finish the read cycle correctly.
	0	EEWRITE	0b	Initiate EEPROM write cycle ⁽⁴⁾⁽⁹⁾ 0 – No EEPROM write cycle 1 – Start EEPROM write cycle (internal registers are saved to the EEPROM)
07h-0Fh		—	0h	Unused address range

- (7) These are the bits of the control terminal register (see [Table 10](#)). The user can predefine up to eight different control settings. These settings then can be selected by the external control pins, S0, S1, and S2.
- (8) The internal load capacitor (C1, C2) must be used to achieve the best clock performance. External capacitors should be used only to finely adjust C_L by a few picofarads. The value of C_L can be programmed with a resolution of 1 pF for a crystal load range of 0 pF to 20 pF. For C_L > 20 pF, use additional external capacitors. The device input capacitance value must be considered, which always adds 1.5 pF (6 pF/2 pF) to the selected C_L. For more about VCXO configuring and crystal recommendation, see application report [VCXO Application Guideline for CDCE\(L\)9xx Family](#) (SCAA085).
- (9) The EEPROM WRITE bit must be sent last. This ensures that the content of all internal registers are stored in the EEPROM. The EEWRITE cycle is initiated with the rising edge of the EEWRITE bit. A static level-high does not trigger an EEPROM WRITE cycle. The EEWRITE bit must be reset to low after the programming is completed. The programming status can be monitored by reading out EEPIP. If EELOCK is set to high, no EEPROM programming is possible.

Table 12. PLL1 Configuration Register

OFFSET ⁽¹⁾	BIT ⁽²⁾	ACRONYM	DEFAULT ⁽³⁾	DESCRIPTION																		
10h	7:5	SSC1_7 [2:0]	000b	SSC1: PLL1 SSC selection (modulation amount). ⁽⁴⁾ <table border="0"> <tr> <td>Down</td> <td>Center</td> </tr> <tr> <td>000 (off)</td> <td>000 (off)</td> </tr> <tr> <td>001 – 0.25%</td> <td>001 ± 0.25%</td> </tr> <tr> <td>010 – 0.5%</td> <td>010 ± 0.5%</td> </tr> <tr> <td>011 – 0.75%</td> <td>011 ± 0.75%</td> </tr> <tr> <td>100 – 1.0%</td> <td>100 ± 1.0%</td> </tr> <tr> <td>101 – 1.25%</td> <td>101 ± 1.25%</td> </tr> <tr> <td>110 – 1.5%</td> <td>110 ± 1.5%</td> </tr> <tr> <td>111 – 2.0%</td> <td>111 ± 2.0%</td> </tr> </table>	Down	Center	000 (off)	000 (off)	001 – 0.25%	001 ± 0.25%	010 – 0.5%	010 ± 0.5%	011 – 0.75%	011 ± 0.75%	100 – 1.0%	100 ± 1.0%	101 – 1.25%	101 ± 1.25%	110 – 1.5%	110 ± 1.5%	111 – 2.0%	111 ± 2.0%
	Down	Center																				
	000 (off)	000 (off)																				
001 – 0.25%	001 ± 0.25%																					
010 – 0.5%	010 ± 0.5%																					
011 – 0.75%	011 ± 0.75%																					
100 – 1.0%	100 ± 1.0%																					
101 – 1.25%	101 ± 1.25%																					
110 – 1.5%	110 ± 1.5%																					
111 – 2.0%	111 ± 2.0%																					
4:2	SSC1_6 [2:0]	000b																				
1:0	SSC1_5 [2:1]	000b																				
7	SSC1_5 [0]																					
11h	6:4	SSC1_4 [2:0]	000b																			
	3:1	SSC1_3 [2:0]	000b																			
	0	SSC1_2 [2]	000b																			
12h	7:6	SSC1_2 [1:0]	000b																			
	5:3	SSC1_1 [2:0]																				
	2:0	SSC1_0 [2:0]																				
13h	7	FS1_7	0b	FS1_x: PLL1 frequency selection ⁽⁴⁾ 0 – f _{VC01_0} (predefined by PLL1_0 – multiplier/divider value) 1 – f _{VC01_1} (predefined by PLL1_1 – multiplier/divider value)																		
	6	FS1_6	0b																			
	5	FS1_5	0b																			
	4	FS1_4	0b																			
	3	FS1_3	0b																			
	2	FS1_2	0b																			
	1	FS1_1	0b																			
	0	FS1_0	0b																			

- (1) Writing data beyond 20h may adversely affect device function.
- (2) All data is transferred MSB-first.
- (3) Unless a custom setting is used
- (4) The user can predefine up to eight different control settings. In normal device operation, these settings can be selected by the external control pins, S0, S1, and S2.

Table 12. PLL1 Configuration Register (continued)

OFFSET ⁽¹⁾	BIT ⁽²⁾	ACRONYM	DEFAULT ⁽³⁾	DESCRIPTION	
14h	7	MUX1	0b	PLL1 multiplexer:	0 – PLL1 1 – PLL1 bypass (PLL1 is in power down)
	6	M2	1b	Output Y2 multiplexer:	0 – Pdiv1 1 – Pdiv2
	5:4	M3	10b	Output Y3 Multiplexer:	00 – Pdiv1-divider 01 – Pdiv2-divider 10 – Pdiv3-divider 11 – Reserved
	3:2	Y2Y3_ST1	00b	Y2, Y3- State0/1 definition:	00 – Y2 and Y3 disabled to Hi-Z state (PLL1 is in power down) 01 – Y2 and Y3 disabled to Hi-Z state
	1:0	Y2Y3_ST0	01b		10 – Y2 and Y3 disabled to low 11 – Y2 and Y3 enabled
15h	7	Y2Y3_7	0b	Y2Y3_x output state selection. ⁽⁴⁾ 0 – State0 (predefined by Y2Y3_ST0) 1 – State1 (predefined by Y2Y3_ST1)	
	6	Y2Y3_6	0b		
	5	Y2Y3_5	0b		
	4	Y2Y3_4	0b		
	3	Y2Y3_3	0b		
	2	Y2Y3_2	0b		
	1	Y2Y3_1	0b		
	0	Y2Y3_0	0b		
16h	7	SSC1DC	0b	PLL1 SSC down or center selection:	0 – Down 1 – Center
	6:0	Pdiv2	00h	7-bit Y2-output-divider Pdiv2:	0 – Reset and standby 1 to 127 – Divider value
17h	7	—	0b	Reserved – do not write other than 0	
	6:0	Pdiv3	00h	7-bit Y3-output-divider Pdiv3:	0 – Reset and standby 1 to 127 – Divider value
18h	7:0	PLL1_0N [11:4]	1FFh	PLL1_0 ⁽⁵⁾ : 30-bit multiplier or divider value for frequency f_{VCO1_0} (for more information, see PLL Frequency Planning).	
19h	7:4	PLL1_0N [3:0]			
	3:0	PLL1_0R [8:5]	000h		
1Ah	7:3	PLL1_0R[4:0]	10h		
	2:0	PLL1_0Q [5:3]			
1Bh	7:5	PLL1_0Q [2:0]	100b		
	4:2	PLL1_0P [2:0]			
	1:0	VCO1_0_RANGE	00b		
1Ch	7:0	PLL1_1N [11:4]	1FFh	PLL1_1 ⁽⁵⁾ : 30-bit multiplier or divider value for frequency f_{VCO1_1} (for more information, see PLL Frequency Planning).	
1Dh	7:4	PLL1_1N [3:0]			
	3:0	PLL1_1R [8:5]	000h		
1Eh	7:3	PLL1_1R[4:0]	10h		
	2:0	PLL1_1Q [5:3]			
1Fh	7:5	PLL1_1Q [2:0]	100b		
	4:2	PLL1_1P [2:0]			
	1:0	VCO1_1_RANGE	00b		

(5) PLL settings limits: $16 \leq q \leq 63$, $0 \leq p \leq 7$, $0 \leq r \leq 511$, $0 < N < 4096$

10 Application and Implementation

NOTE

Information in the following applications sections is not part of the TI component specification, and TI does not warrant its accuracy or completeness. TI's customers are responsible for determining suitability of components for their purposes. Customers should validate and test their design implementation to confirm system functionality.

10.1 Application Information

The CDCE813-Q1 device is an easy-to-use, high-performance, programmable CMOS clock synthesizer which can be used as a crystal buffer, clock synthesizer with separate output supply pin. The CDCE813-Q1 device features an on-chip loop filter and spread-spectrum modulation. Programming can be done through the I2C interface, or previously saved settings can be loaded from on-chip EEPROM. The pins S0, S1, and S2 can be programmed as control pins to select various output settings. This section shows some examples of using the CDCE813-Q1 device in various applications.

10.2 Typical Application

Figure 13 shows the application example of CDCE813-Q1 in combination with an SoC processor and an FPD-Link3 serializer, serving as a PCLK jitter cleaner.

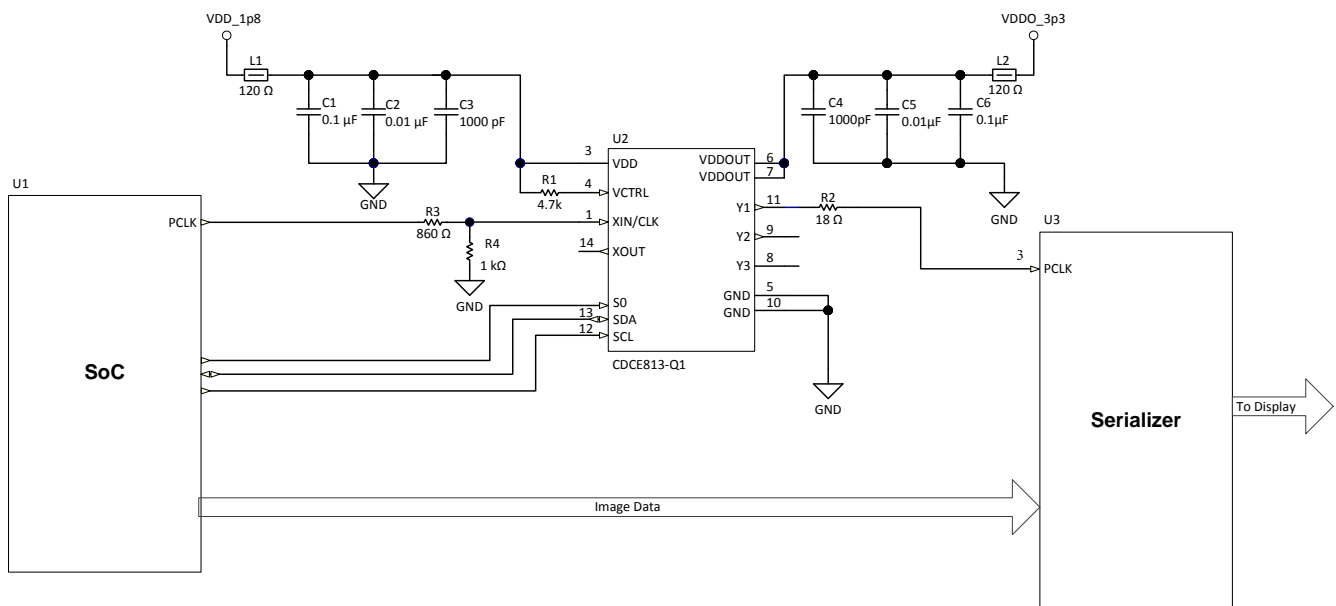

Copyright © 2017, Texas Instruments Incorporated

Figure 13. PCLK Jitter Cleaner Reference Design

10.2.1 Design Requirements

The CDCE813-Q1 device supports spread-spectrum clocking (SSC) with multiple control parameters:

- Modulation amount (%)
- Modulation frequency (>20 kHz)
- Center spread or down spread (\pm or $-$)

Typical Application (continued)

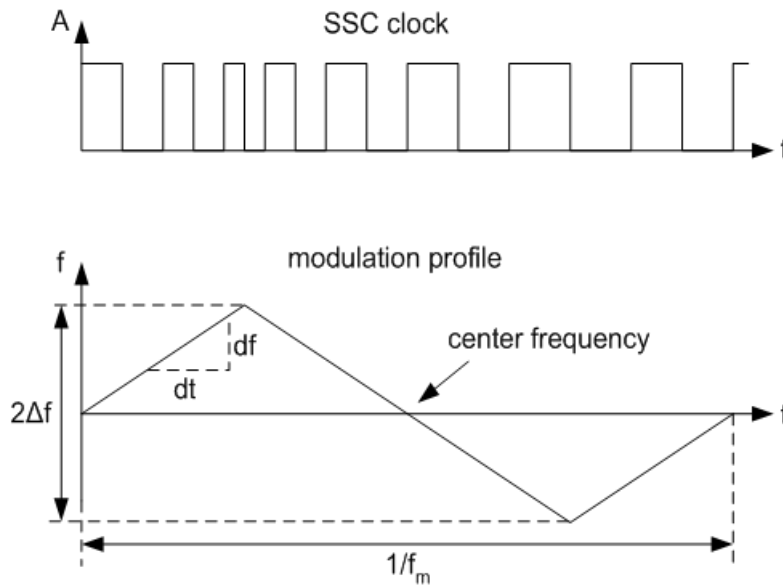
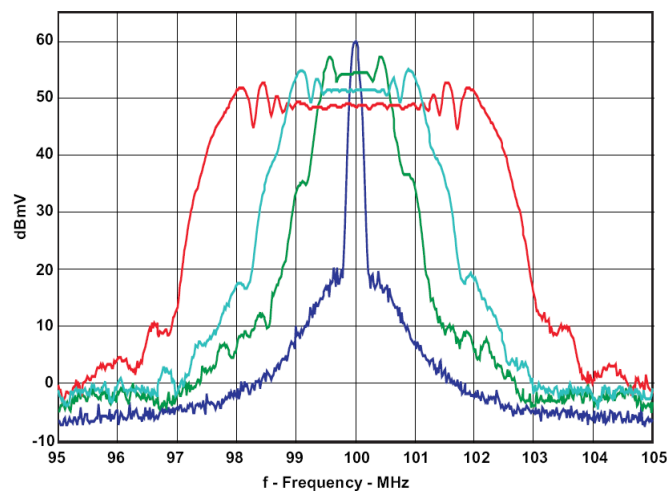

Figure 14. Modulation Frequency (f_m) and Modulation Amount

10.2.2 Detailed Design Procedure

10.2.2.1 Spread-Spectrum Clock (SSC)

Spread-spectrum modulation is a method to spread emitted energy over a larger bandwidth. In clocking, spread spectrum can reduce electromagnetic interference (EMI) by reducing the level of emission from clock distribution network.



CDCS502 with a 25-MHz Crystal, FS = 1, f_{OUT} = 100 MHz, and 0%, ± 0.5 , ± 1 %, and ± 2 % SSC

Figure 15. Comparison Between Typical Clock Power Spectrum and Spread-Spectrum Clock

Spread spectrum clocking can be used to help reduce EMI to meet design specifications. For example, a specified EMI threshold of 55 dB/mV would require ± 1 % spread-spectrum clocking to meet this requirement.

Typical Application (continued)

10.2.2.2 PLL Frequency Planning

At a given input frequency (f_{IN}), the output frequency (f_{OUT}) of the CDCE813-Q1 device is calculated with [Equation 1](#).

$$f_{OUT} = \frac{f_{IN}}{Pdiv} \times \frac{N}{M}$$

- M (1 to 511) and N (1 to 4095) are the multiplier or divider values of the PLL,
- and Pdiv (1 to 127) is the output divider.

(1)

The target VCO frequency (f_{VCO}) of each PLL is calculated with [Equation 2](#).

$$f_{VCO} = f_{IN} \times \frac{N}{M}$$
(2)

The PLL internally operates as fractional divider and needs the following multiplier or divider settings:

- N
- $P = 4 - \text{int}(\log_2 N / M)$; if $P < 0$ then $P = 0$
- $Q = \text{int}(N' / M)$
- $R = N' - M \times Q$

where

- $\text{int}(X)$ = integer portion of X
- $N' = N \times 2^P$
- $N \geq M$

$$80 \text{ MHz} \leq f_{VCO} \leq 230 \text{ MHz}$$

$$16 \leq Q \leq 63$$

$$0 \leq P \leq 4$$

$$0 \leq R \leq 51$$

Example:

for $f_{IN} = 27 \text{ MHz}$; $M = 1$; $N = 4$; $Pdiv = 2$

$$\rightarrow f_{OUT} = 54 \text{ MHz}$$

$$\rightarrow f_{VCO} = 108 \text{ MHz}$$

$$\rightarrow P = 4 - \text{int}(\log_2 4) = 4 - 2 = 2$$

$$\rightarrow N' = 4 \times 2^2 = 16$$

$$\rightarrow Q = \text{int}(16) = 16$$

$$\rightarrow R = 16 - 16 = 0$$

for $f_{IN} = 27 \text{ MHz}$; $M = 2$; $N = 11$; $Pdiv = 2$

$$\rightarrow f_{OUT} = 74.25 \text{ MHz}$$

$$\rightarrow f_{VCO} = 148.50 \text{ MHz}$$

$$\rightarrow P = 4 - \text{int}(\log_2 5.5) = 4 - 2 = 2$$

$$\rightarrow N' = 11 \times 2^2 = 44$$

$$\rightarrow Q = \text{int}(22) = 22$$

$$\rightarrow R = 44 - 44 = 0$$

The values for P, Q, R, and N' are automatically calculated when using TI Pro-Clock™ software.

10.2.2.3 Crystal Oscillator Start-Up

When the CDCE813-Q1 device can be used as a crystal buffer, the crystal oscillator start-up dominates the start-up time compared to the internal PLL lock time. [Figure 16](#) shows the oscillator start-up sequence for a 27-MHz crystal input with an 8-pF load. The start-up time for the crystal is on the order of approximately 250 μs compared to approximately 10 μs of lock time. In general, lock time is an order of magnitude less compared to the crystal start-up time.

Typical Application (continued)

Figure 16. Crystal Oscillator Start-Up vs PLL Lock Time
10.2.2.4 Frequency Adjustment With Crystal Oscillator Pulling

The frequency for the CDCE813-Q1 device is adjusted for media and other applications with the VCXO control input V_{ctr} . If a PWM-modulated signal is used as a control signal for the VCXO, an external filter is needed.

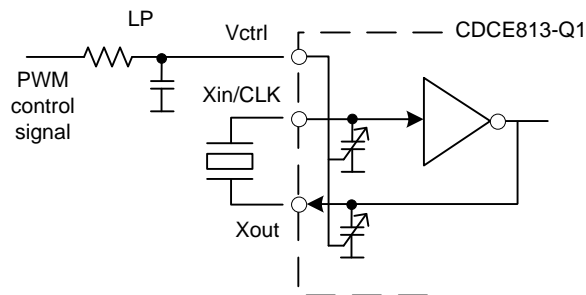

Copyright © 2017, Texas Instruments Incorporated

Figure 17. Frequency Adjustment Using PWM Input to the VCXO Control
10.2.2.5 Unused Inputs and Outputs

If VCXO-pulling functionality is not required, V_{ctr} should be left floating. All other unused inputs should be set to GND. Unused outputs should be left floating.

If one output block is not used, TI recommends disabling it. However, TI recommends providing a supply for all output blocks, even if they are disabled.

10.2.2.6 Switching Between XO and VCXO Mode

When the CDCE813-Q1 device is in the crystal-oscillator or VCXO configuration, the internal capacitors require different internal capacitance. The following steps are recommended to switch to VCXO mode when the configuration for the on-chip capacitor is still set for XO mode. To center the output frequency to 0 ppm:

1. While in XO mode, put $V_{ctr} = V_{DD} / 2$
2. Switch from XO mode to VCXO mode
3. Program the internal capacitors to obtain 0 ppm at the output.

Typical Application (continued)

10.2.3 Application Curves

Figure 18, Figure 19, Figure 20, and Figure 21 show CDCE813-Q1 measurements with the SSC feature enabled. Device configuration: 27-MHz input, 27-MHz output.

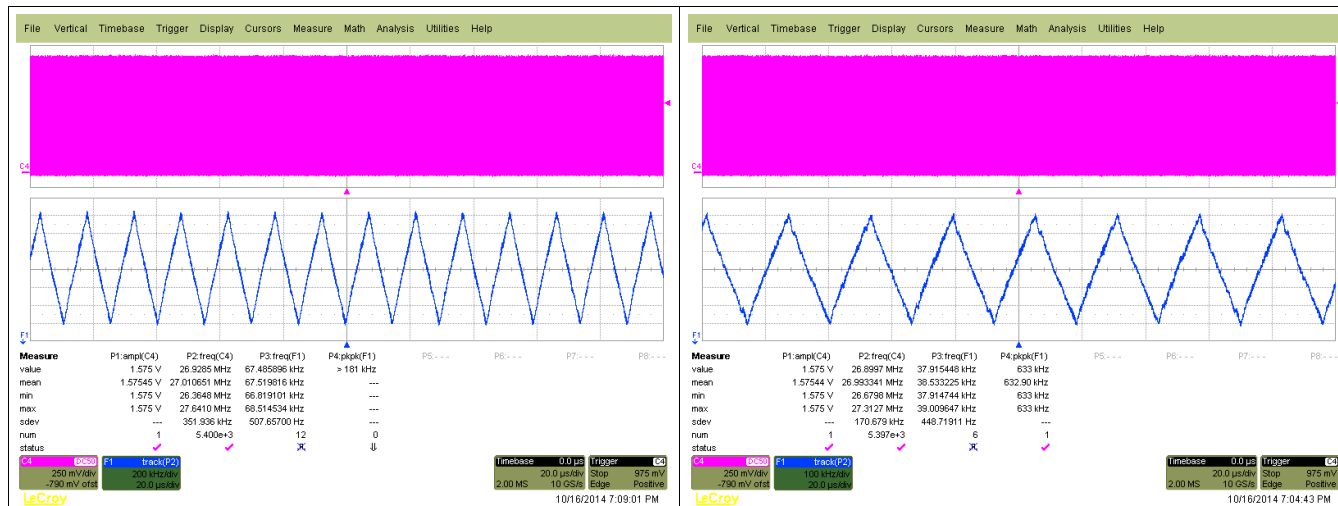

Figure 18. $f_{OUT} = 27$ MHz, VCO frequency < 125 MHz, SSC (2% Center)

Figure 19. $f_{OUT} = 27$ MHz, VCO frequency > 175 MHz, SSC (1%, Center)

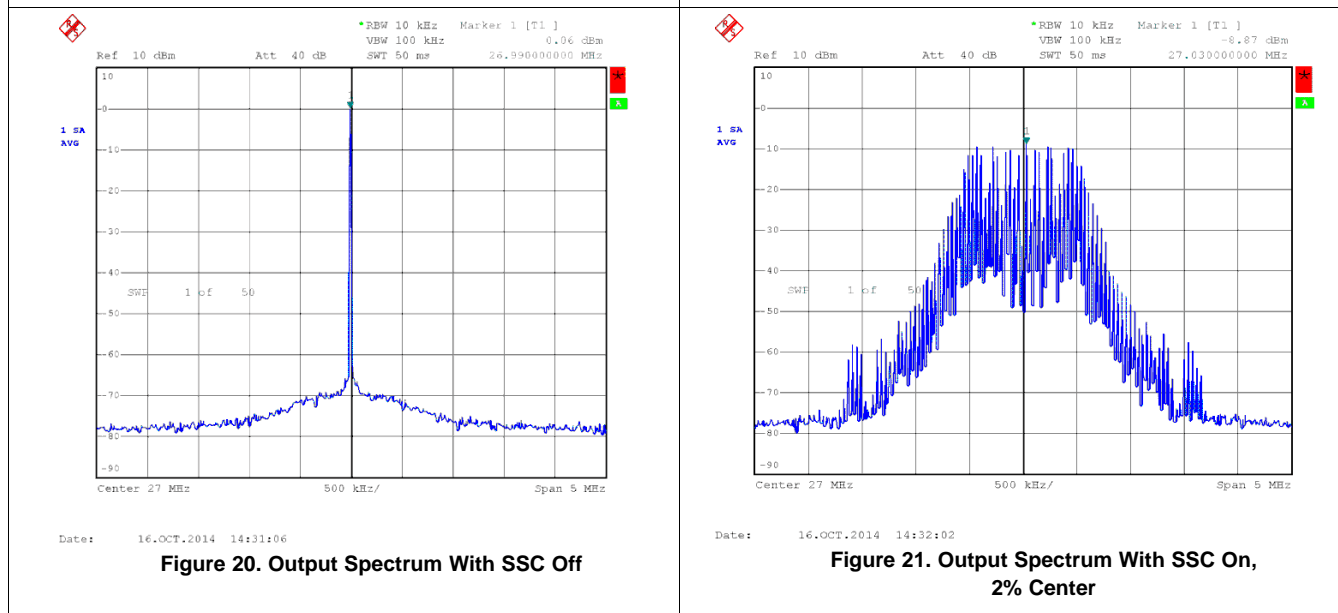

Figure 20. Output Spectrum With SSC Off

Figure 21. Output Spectrum With SSC On, 2% Center

11 Power Supply Recommendations

There is no restriction on the power-up sequence. In case V_{DDOUT} is applied first, TI recommends grounding the V_{DD} . In case V_{DDOUT} is powered while V_{DD} is floating, there is a risk of high current flowing on the V_{DDOUT} pins.

The device has a power-up control that is connected to the 1.8-V supply. This keeps the whole device disabled until the 1.8-V supply reaches a sufficient voltage level. Then the device switches on all internal components, including the outputs. If a 3.3-V V_{DDOUT} is available before the 1.8-V, the outputs stay disabled until the 1.8-V supply has reached a certain level.

12 Layout

12.1 Layout Guidelines

When the CDCE813-Q1 device is used as a crystal buffer, any parasitic across the crystal affect the pulling range of the VCXO. Therefore, take care in placing the crystal units on the board. Crystals must be placed as close to the device as possible, ensuring that the routing lines from the crystal terminals to Xin and Xout have the same length.

If possible, cut out both ground plane and power plane under the area where the crystal and the routing to the device are placed. In this area, always avoid routing any other signal line, as it could be a source of noise coupling.

Additional discrete capacitors can be required to meet the load capacitance specification of certain crystals. For example, a 10.7-pF load capacitor is not fully programmable on the chip, because the internal capacitor can range from 0 pF to 20 pF with steps of 1 pF. The 0.7-pF capacitor therefore can be discretely added on top of an internal 10-pF capacitor.

To minimize the inductive influence of the trace, TI recommends placing this small capacitor as close to the device as possible and symmetrically with respect to Xin and Xout.

Figure 22 shows a conceptual layout detailing recommended placement of power-supply bypass capacitors. For component-side mounting, use 0402 body-size capacitors to facilitate signal routing. Keep the connections between the bypass capacitors and the power supply on the device as short as possible. Ground the other side of the capacitor using a low-impedance connection to the ground plane.

12.2 Layout Example

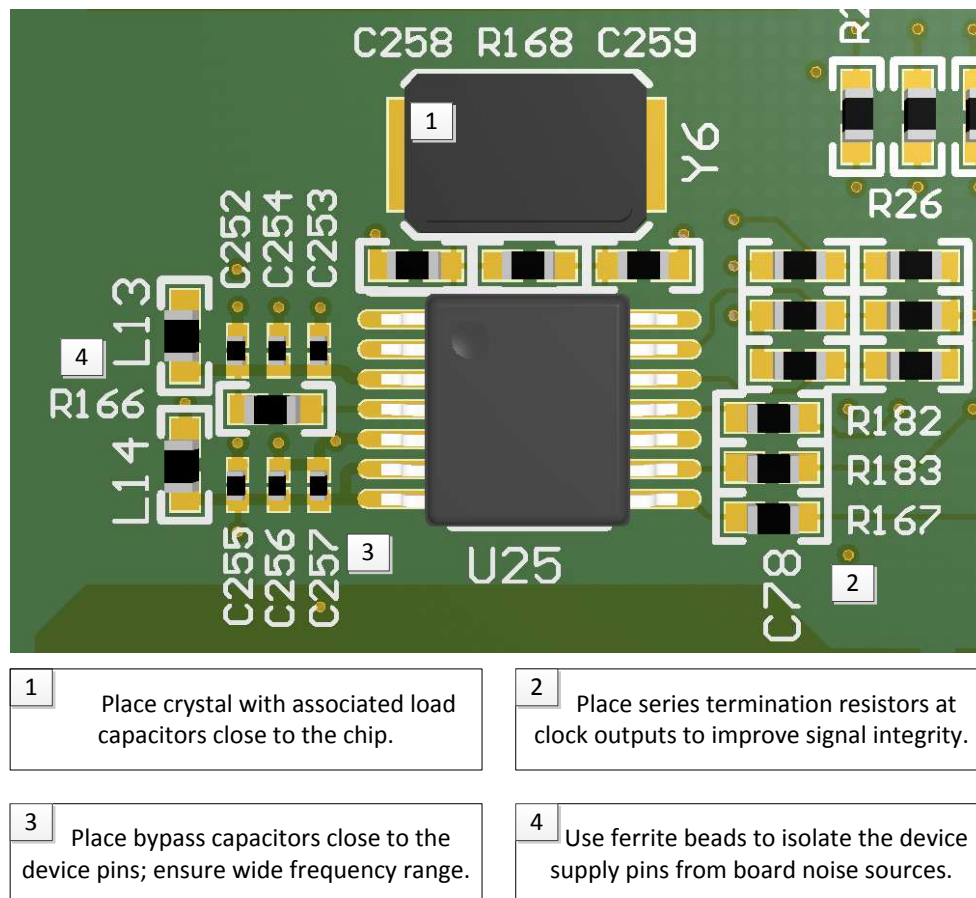

Figure 22. Annotated Layout

13 Device and Documentation Support

13.1 Documentation Support

13.1.1 Related Documentation

For related documentation see the following:

- [VCXO Application Guideline for CDCE\(L\)9xx Family](#) (SCAA085)
- [Practical Consideration on Choosing a Crystal for CDCE\(L\)9xx Family](#) (SLEA071)
- [General I2C/EEPROM Usage for the CDCE\(L\)9xx Family](#) (SCAA104)
- [Crystal Or Crystal Oscillator Replacement with Silicon Devices](#) (SNAA217)
- [Usage of \$\mu\text{C}\$ for CDCE\(L\)949, CDCE\(L\)937, CDCE\(L\)925, CDCE\(L\)813](#) (SCAA105)
- [Generating Low Phase-Noise Clocks for Audio Data Converters from Low Frequency Word Clock](#) (SCAA088)

13.2 Receiving Notification of Documentation Updates

To receive notification of documentation updates, navigate to the device product folder on ti.com. In the upper right corner, click on *Alert me* to register and receive a weekly digest of any product information that has changed. For change details, review the revision history included in any revised document.

13.3 Community Resources

The following links connect to TI community resources. Linked contents are provided "AS IS" by the respective contributors. They do not constitute TI specifications and do not necessarily reflect TI's views; see TI's [Terms of Use](#).

TI E2E™ Online Community *TI's Engineer-to-Engineer (E2E) Community*. Created to foster collaboration among engineers. At e2e.ti.com, you can ask questions, share knowledge, explore ideas and help solve problems with fellow engineers.

Design Support *TI's Design Support* Quickly find helpful E2E forums along with design support tools and contact information for technical support.

13.4 Trademarks

DaVinci, OMAP, Pro-Clock, E2E are trademarks of Texas Instruments.
Bluetooth is a registered trademark of Bluetooth SIG, Inc.
All other trademarks are the property of their respective owners.

13.5 Electrostatic Discharge Caution



These devices have limited built-in ESD protection. The leads should be shorted together or the device placed in conductive foam during storage or handling to prevent electrostatic damage to the MOS gates.

13.6 Glossary

[SLYZ022](#) — *TI Glossary*.

This glossary lists and explains terms, acronyms, and definitions.

14 Mechanical, Packaging, and Orderable Information

The following pages include mechanical, packaging, and orderable information. This information is the most current data available for the designated devices. This data is subject to change without notice and revision of this document. For browser-based versions of this data sheet, refer to the left-hand navigation.

PACKAGING INFORMATION

Orderable Device	Status (1)	Package Type	Package Drawing	Pins	Package Qty	Eco Plan (2)	Lead/Ball Finish (6)	MSL Peak Temp (3)	Op Temp (°C)	Device Marking (4/5)	Samples
CDCE813QPWRQ1	ACTIVE	TSSOP	PW	14	2000	Green (RoHS & no Sb/Br)	CU NIPDAU	Level-3-260C-168 HR	-40 to 105	CE813Q	Samples

(1) The marketing status values are defined as follows:

ACTIVE: Product device recommended for new designs.

LIFEBUY: TI has announced that the device will be discontinued, and a lifetime-buy period is in effect.

NRND: Not recommended for new designs. Device is in production to support existing customers, but TI does not recommend using this part in a new design.

PREVIEW: Device has been announced but is not in production. Samples may or may not be available.

OBSELETE: TI has discontinued the production of the device.

(2) **RoHS:** TI defines "RoHS" to mean semiconductor products that are compliant with the current EU RoHS requirements for all 10 RoHS substances, including the requirement that RoHS substance do not exceed 0.1% by weight in homogeneous materials. Where designed to be soldered at high temperatures, "RoHS" products are suitable for use in specified lead-free processes. TI may reference these types of products as "Pb-Free".

RoHS Exempt: TI defines "RoHS Exempt" to mean products that contain lead but are compliant with EU RoHS pursuant to a specific EU RoHS exemption.

Green: TI defines "Green" to mean the content of Chlorine (Cl) and Bromine (Br) based flame retardants meet JS709B low halogen requirements of <=1000ppm threshold. Antimony trioxide based flame retardants must also meet the <=1000ppm threshold requirement.

(3) MSL, Peak Temp. - The Moisture Sensitivity Level rating according to the JEDEC industry standard classifications, and peak solder temperature.

(4) There may be additional marking, which relates to the logo, the lot trace code information, or the environmental category on the device.

(5) Multiple Device Markings will be inside parentheses. Only one Device Marking contained in parentheses and separated by a "~" will appear on a device. If a line is indented then it is a continuation of the previous line and the two combined represent the entire Device Marking for that device.

(6) Lead/Ball Finish - Orderable Devices may have multiple material finish options. Finish options are separated by a vertical ruled line. Lead/Ball Finish values may wrap to two lines if the finish value exceeds the maximum column width.

Important Information and Disclaimer:The information provided on this page represents TI's knowledge and belief as of the date that it is provided. TI bases its knowledge and belief on information provided by third parties, and makes no representation or warranty as to the accuracy of such information. Efforts are underway to better integrate information from third parties. TI has taken and continues to take reasonable steps to provide representative and accurate information but may not have conducted destructive testing or chemical analysis on incoming materials and chemicals. TI and TI suppliers consider certain information to be proprietary, and thus CAS numbers and other limited information may not be available for release.

In no event shall TI's liability arising out of such information exceed the total purchase price of the TI part(s) at issue in this document sold by TI to Customer on an annual basis.

TAPE AND REEL INFORMATION



QUADRANT ASSIGNMENTS FOR PIN 1 ORIENTATION IN TAPE



*All dimensions are nominal

Device	Package Type	Package Drawing	Pins	SPQ	Reel Diameter (mm)	Reel Width W1 (mm)	A0 (mm)	B0 (mm)	K0 (mm)	P1 (mm)	W (mm)	Pin1 Quadrant
CDCE813QPWRQ1	TSSOP	PW	14	2000	330.0	12.4	6.9	5.6	1.6	8.0	12.0	Q1

TAPE AND REEL BOX DIMENSIONS



*All dimensions are nominal

Device	Package Type	Package Drawing	Pins	SPQ	Length (mm)	Width (mm)	Height (mm)
CDCE813QPWRQ1	TSSOP	PW	14	2000	367.0	367.0	35.0



MECHANICAL DATA

PW (R-PDSO-G14)

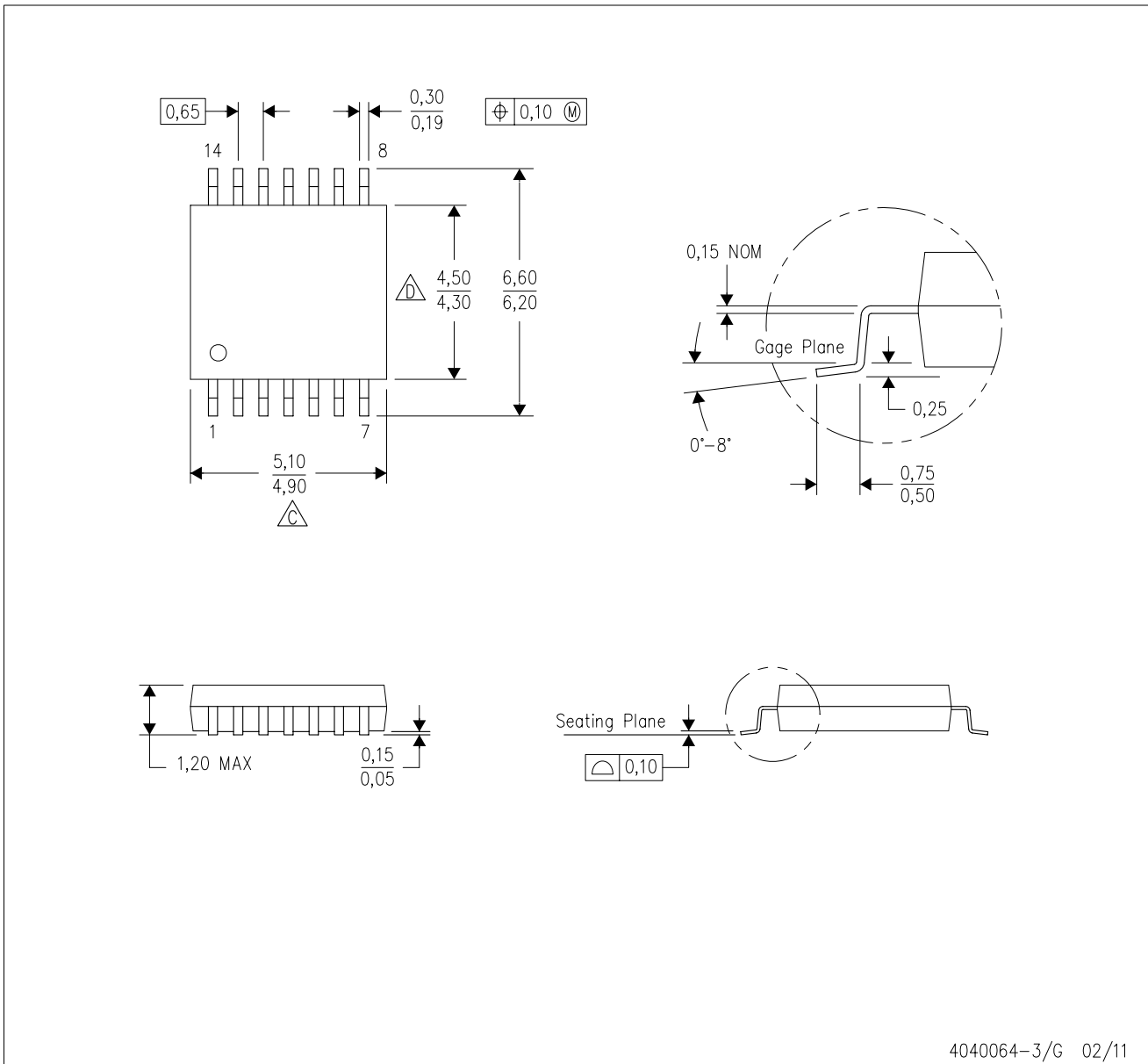
PLASTIC SMALL OUTLINE



4040064-3/G 02/11

- NOTES:
- A. All linear dimensions are in millimeters. Dimensioning and tolerancing per ASME Y14.5M-1994.
 - B. This drawing is subject to change without notice.
 -  Body length does not include mold flash, protrusions, or gate burrs. Mold flash, protrusions, or gate burrs shall not exceed 0,15 each side.
 -  Body width does not include interlead flash. Interlead flash shall not exceed 0,25 each side.
 - E. Falls within JEDEC MO-153

PW (R-PDSO-G14)

PLASTIC SMALL OUTLINE



4211284-2/G 08/15

- NOTES:
- All linear dimensions are in millimeters.
 - This drawing is subject to change without notice.
 - Publication IPC-7351 is recommended for alternate designs.
 - Laser cutting apertures with trapezoidal walls and also rounding corners will offer better paste release. Customers should contact their board assembly site for stencil design recommendations. Refer to IPC-7525 for other stencil recommendations.
 - Customers should contact their board fabrication site for solder mask tolerances between and around signal pads.

IMPORTANT NOTICE

Texas Instruments Incorporated (TI) reserves the right to make corrections, enhancements, improvements and other changes to its semiconductor products and services per JESD46, latest issue, and to discontinue any product or service per JESD48, latest issue. Buyers should obtain the latest relevant information before placing orders and should verify that such information is current and complete.

TI's published terms of sale for semiconductor products (<http://www.ti.com/sc/docs/stdterms.htm>) apply to the sale of packaged integrated circuit products that TI has qualified and released to market. Additional terms may apply to the use or sale of other types of TI products and services.

Reproduction of significant portions of TI information in TI data sheets is permissible only if reproduction is without alteration and is accompanied by all associated warranties, conditions, limitations, and notices. TI is not responsible or liable for such reproduced documentation. Information of third parties may be subject to additional restrictions. Resale of TI products or services with statements different from or beyond the parameters stated by TI for that product or service voids all express and any implied warranties for the associated TI product or service and is an unfair and deceptive business practice. TI is not responsible or liable for any such statements.

Buyers and others who are developing systems that incorporate TI products (collectively, "Designers") understand and agree that Designers remain responsible for using their independent analysis, evaluation and judgment in designing their applications and that Designers have full and exclusive responsibility to assure the safety of Designers' applications and compliance of their applications (and of all TI products used in or for Designers' applications) with all applicable regulations, laws and other applicable requirements. Designer represents that, with respect to their applications, Designer has all the necessary expertise to create and implement safeguards that (1) anticipate dangerous consequences of failures, (2) monitor failures and their consequences, and (3) lessen the likelihood of failures that might cause harm and take appropriate actions. Designer agrees that prior to using or distributing any applications that include TI products, Designer will thoroughly test such applications and the functionality of such TI products as used in such applications.

TI's provision of technical, application or other design advice, quality characterization, reliability data or other services or information, including, but not limited to, reference designs and materials relating to evaluation modules, (collectively, "TI Resources") are intended to assist designers who are developing applications that incorporate TI products; by downloading, accessing or using TI Resources in any way, Designer (individually or, if Designer is acting on behalf of a company, Designer's company) agrees to use any particular TI Resource solely for this purpose and subject to the terms of this Notice.

TI's provision of TI Resources does not expand or otherwise alter TI's applicable published warranties or warranty disclaimers for TI products, and no additional obligations or liabilities arise from TI providing such TI Resources. TI reserves the right to make corrections, enhancements, improvements and other changes to its TI Resources. TI has not conducted any testing other than that specifically described in the published documentation for a particular TI Resource.

Designer is authorized to use, copy and modify any individual TI Resource only in connection with the development of applications that include the TI product(s) identified in such TI Resource. NO OTHER LICENSE, EXPRESS OR IMPLIED, BY ESTOPPEL OR OTHERWISE TO ANY OTHER TI INTELLECTUAL PROPERTY RIGHT, AND NO LICENSE TO ANY TECHNOLOGY OR INTELLECTUAL PROPERTY RIGHT OF TI OR ANY THIRD PARTY IS GRANTED HEREIN, including but not limited to any patent right, copyright, mask work right, or other intellectual property right relating to any combination, machine, or process in which TI products or services are used. Information regarding or referencing third-party products or services does not constitute a license to use such products or services, or a warranty or endorsement thereof. Use of TI Resources may require a license from a third party under the patents or other intellectual property of the third party, or a license from TI under the patents or other intellectual property of TI.

TI RESOURCES ARE PROVIDED "AS IS" AND WITH ALL FAULTS. TI DISCLAIMS ALL OTHER WARRANTIES OR REPRESENTATIONS, EXPRESS OR IMPLIED, REGARDING RESOURCES OR USE THEREOF, INCLUDING BUT NOT LIMITED TO ACCURACY OR COMPLETENESS, TITLE, ANY EPIDEMIC FAILURE WARRANTY AND ANY IMPLIED WARRANTIES OF MERCHANTABILITY, FITNESS FOR A PARTICULAR PURPOSE, AND NON-INFRINGEMENT OF ANY THIRD PARTY INTELLECTUAL PROPERTY RIGHTS. TI SHALL NOT BE LIABLE FOR AND SHALL NOT DEFEND OR INDEMNIFY DESIGNER AGAINST ANY CLAIM, INCLUDING BUT NOT LIMITED TO ANY INFRINGEMENT CLAIM THAT RELATES TO OR IS BASED ON ANY COMBINATION OF PRODUCTS EVEN IF DESCRIBED IN TI RESOURCES OR OTHERWISE. IN NO EVENT SHALL TI BE LIABLE FOR ANY ACTUAL, DIRECT, SPECIAL, COLLATERAL, INDIRECT, PUNITIVE, INCIDENTAL, CONSEQUENTIAL OR EXEMPLARY DAMAGES IN CONNECTION WITH OR ARISING OUT OF TI RESOURCES OR USE THEREOF, AND REGARDLESS OF WHETHER TI HAS BEEN ADVISED OF THE POSSIBILITY OF SUCH DAMAGES.

Unless TI has explicitly designated an individual product as meeting the requirements of a particular industry standard (e.g., ISO/TS 16949 and ISO 26262), TI is not responsible for any failure to meet such industry standard requirements.

Where TI specifically promotes products as facilitating functional safety or as compliant with industry functional safety standards, such products are intended to help enable customers to design and create their own applications that meet applicable functional safety standards and requirements. Using products in an application does not by itself establish any safety features in the application. Designers must ensure compliance with safety-related requirements and standards applicable to their applications. Designer may not use any TI products in life-critical medical equipment unless authorized officers of the parties have executed a special contract specifically governing such use. Life-critical medical equipment is medical equipment where failure of such equipment would cause serious bodily injury or death (e.g., life support, pacemakers, defibrillators, heart pumps, neurostimulators, and implantables). Such equipment includes, without limitation, all medical devices identified by the U.S. Food and Drug Administration as Class III devices and equivalent classifications outside the U.S.

TI may expressly designate certain products as completing a particular qualification (e.g., Q100, Military Grade, or Enhanced Product). Designers agree that it has the necessary expertise to select the product with the appropriate qualification designation for their applications and that proper product selection is at Designers' own risk. Designers are solely responsible for compliance with all legal and regulatory requirements in connection with such selection.

Designer will fully indemnify TI and its representatives against any damages, costs, losses, and/or liabilities arising out of Designer's non-compliance with the terms and provisions of this Notice.