

SOT-23 Plastic-Encapsulate MOSFETS

FEATURE

TrenchFET Power MOSFET

APPLICATIONS

- Load Switch for Portable Devices
- DC/DC Converter

MARKING: A2

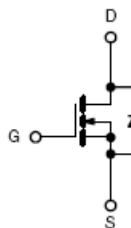

SOT-23



1. GATE
2. SOURCE
3. DRAIN

Maximum ratings (T_a=25°C unless otherwise noted)

Characteristic 特性參數	Symbol 符號	Max 最大值	Unit 單位
Drain-Source Voltage 漏極-源極電壓	BV_{DSS}	20	V
Gate- Source Voltage 柵極-源極電壓	V_{GS}	±10	V
Drain Current (continuous) 漏極電流-連續	I_D	3.5	A
Drain Current (pulsed) 漏極電流-脉冲	I_{DM}	11	A
Total Device Dissipation 總耗散功率 T _A =25°C 環境溫度為 25°C	P_D	1000	mW
Junction 結溫	T_J	150	°C
Storage Temperature 儲存溫度	T_{stg}	-55to+150	°C

SOT-23 Plastic-Encapsulate MOSFETS

Electrical characteristics (T_a=25°C unless otherwise noted)

Characteristic 特性參數	Symbol 符號	Min 最小值	Typ 典型值	Max 最大值	Unit 單位
Drain-Source Breakdown Voltage 漏極-源極擊穿電壓(I _D = 250uA, V _{GS} =0V)	BV _{DSS}	20	—	—	V
Gate Threshold Voltage 柵極開啓電壓(I _D = 250uA, V _{GS} = V _{DS})	V _{GS(th)}	0.5	—	1.5	V
Diode Forward Voltage Drop 內附二極管正向壓降(I _S = 0.75A, V _{GS} =0V)	V _{SD}	—	—	1.5	V
Zero Gate Voltage Drain Current 零柵壓漏極電流(V _{GS} =0V, V _{DS} = 16V) (V _{GS} =0V, V _{DS} = 16V, T _A =55°C)	I _{DSS}	—	—	1 10	uA
Gate Body Leakage 柵極漏電流(V _{GS} =±10V, V _{DS} =0V)	I _{GSS}	—	—	±100	nA
Static Drain-Source On-State Resistance 靜態漏源導通電阻(I _D =2.8A, V _{GS} =4.5V) (I _D =2A, V _{GS} =2.5V)	R _{DS(ON)}	—	—	60 80	mΩ
Input Capacitance 輸入電容 (V _{GS} =0V, V _{DS} = 10V, f=1MHz)	C _{ISS}	—	—	800	pF
Common Source Output Capacitance 共源輸出電容(V _{GS} =0V, V _{DS} = 10V, f=1MHz)	C _{OSS}	—	—	200	pF
Turn-ON Time 開啓時間 (V _{DS} = 10V, I _D = 3.5A, R _{GEN} =10Ω)	t _(on)	—	—	20	ns
Turn-OFF Time 關斷時間 (V _{DS} = 10V, I _D = 3.5A, R _{GEN} =10Ω)	t _(off)	—	—	80	ns

Pulse Width ≤ 300 μs; Duty Cycle ≤ 2.0%

SOT-23 Plastic-Encapsulate MOSFETS

SOT-23 Package Outline Dimensions

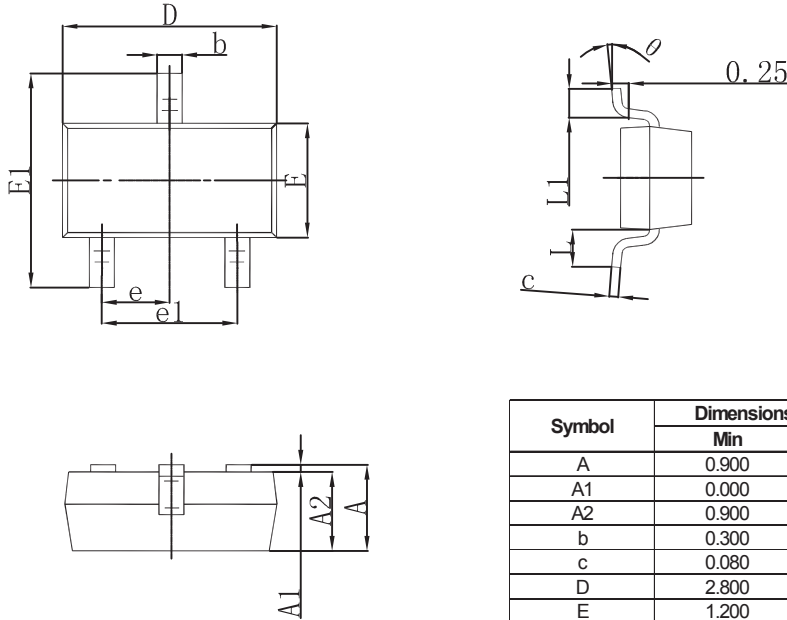

Symbol	Dimensions In Millimeters		Dimensions In Inches	
	Min	Max	Min	Max
A	0.900	1.150	0.035	0.045
A1	0.000	0.100	0.000	0.004
A2	0.900	1.050	0.035	0.041
b	0.300	0.500	0.012	0.020
c	0.080	0.150	0.003	0.006
D	2.800	3.000	0.110	0.118
E	1.200	1.400	0.047	0.055
E1	2.250	2.550	0.089	0.100
e	0.950 TYP		0.037 TYP	
e1	1.800	2.000	0.071	0.079
L	0.550 REF		0.022 REF	
L1	0.300	0.500	0.012	0.020
θ	0°	8°	0°	8°

SOT-23 Suggested Pad Layout

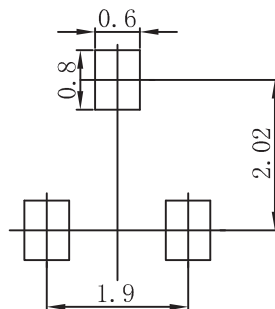

Note:

1. Controlling dimension: in millimeters.
2. General tolerance: ± 0.05mm.
3. The pad layout is for reference purposes only.