

Features

- $R_{DS(ON)} < 0.85\Omega @ V_{GS}=10V$
- Fast switching capability
- Low gate charge
- Lead free in compliance with EU RoHS directive.
- Green molding compound

PRODUCT SUMMARY

V_{DS} (V)	$R_{DS(on)}$ (Ω)	I_D (A)
650	0.85@ $V_{GS}=10V$	12

Mechanical Data

- Case: TO-220AB, ITO-220AB Package
TO-262AB, TO-263AB Package

Ordering Information

Part No.	Package	Packing
AT12N65S	TO-220AB	50pcs / Tube
AF12N65S	ITO-220AB	50pcs / Tube
AK12N65S	TO-262AB	50pcs / Tube
AG12N65S	TO-263AB	800pcs / 13" Reel

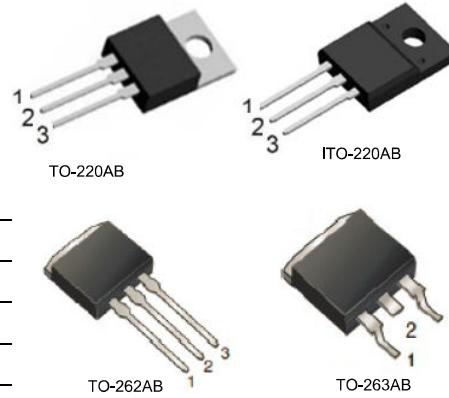

Pin Definition:

1. Gate
2. Drain
3. Source

Block Diagram

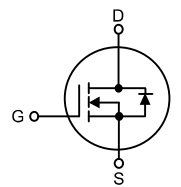

ABSOLUTE MAXIMUM RATINGS ($T_C=25^\circ C$, unless otherwise specified)

PARAMETER	SYMBOL	RATINGS	UNIT
Drain-Source Voltage	V_{DSS}	650	V
Gate-Source Voltage	V_{GSS}	± 30	V
Continuous Drain Current	I_D	12	A
Pulsed Drain Current (Note 2)	I_{DM}	48	A
Avalanche Energy	Single Pulsed (Note 3) E_{AS}	790	mJ
Power Dissipation	TO-220AB/TO-262AB TO-263AB	P_D 225	W
	ITO-220AB	51	W
Junction Temperature	T_J	+150	$^\circ C$
Operating Temperature	T_{OPR}	-55 ~ +150	$^\circ C$
Storage Temperature	T_{STG}	-55 ~ +150	$^\circ C$

Notes: 1. Absolute maximum ratings are those values beyond which the device could be permanently damaged.

Absolute maximum ratings are stress ratings only and functional device operation is not implied.

2. Repetitive Rating : Pulse width limited by T_J

3. $L = 30mH$, $I_{AS} = 7.1A$, $V_{DD} = 50V$, $R_G = 25 \Omega$, Starting $T_J = 25^\circ C$

THERMAL DATA

PARAMETER		SYMBOL	RATING	UNIT
Junction to Ambient	TO-220AB/ITO-220AB TO-262AB/TO-263AB	θ_{JA}	62.5	$^{\circ}\text{C/W}$
Junction to Case	TO-220AB	θ_{JC}	0.56	$^{\circ}\text{C/W}$
	ITO-220AB		2.6	

ELECTRICAL CHARACTERISTICS ($T_C=25^{\circ}\text{C}$, unless otherwise specified)

PARAMETER		SYMBOL	TEST CONDITIONS	MIN	TYP	MAX	UNIT	
OFF CHARACTERISTICS								
Drain-Source Breakdown Voltage		BV_{DSS}	$V_{GS}=0V, I_D=250\mu A$	650			V	
Drain-Source Leakage Current		I_{DSS}	$V_{DS}=650V, V_{GS}=0V$			1	μA	
Gate- Source Leakage Current	Forward	I_{GSS}	$V_{GS}=30V, V_{DS}=0V$			100	nA	
	Reverse		$V_{GS}=-30V, V_{DS}=0V$			-100	nA	
ON CHARACTERISTICS								
Gate Threshold Voltage		$V_{GS(TH)}$	$V_{DS}=V_{GS}, I_D=250\mu A$	2.0		4.0	V	
Static Drain-Source On-State Resistance		$R_{DS(ON)}$	$V_{GS}=10V, I_D=6A$		0.65	0.85	Ω	
DYNAMIC CHARACTERISTICS								
Input Capacitance		C_{ISS}	$V_{DS}=25V, V_{GS}=0V, f=1.0\text{ MHz}$		1480		pF	
Output Capacitance		C_{OSS}				200		pF
Reverse Transfer Capacitance		C_{RSS}				25		pF
SWITCHING CHARACTERISTICS								
Turn-On Delay Time		$t_{D(ON)}$	$V_{DD}=300V, I_D=12A, R_G=25\Omega$ (Note 1, 2)		30		ns	
Turn-On Rise Time		t_R				115		ns
Turn-Off Delay Time		$t_{D(OFF)}$				95		ns
Turn-Off Fall Time		t_F				85		ns
Total Gate Charge		Q_G	$V_{DS}=480V, I_D=12A, V_{GS}=10V$ (Note 1, 2)		42		nC	
Gate-Source Charge		Q_{GS}				8.6		nC
Gate-Drain Charge		Q_{GD}				21		nC
DRAIN-SOURCE DIODE CHARACTERISTICS AND MAXIMUM RATINGS								
Drain-Source Diode Forward Voltage		V_{SD}	$V_{GS}=0V, I_S=12A$			1.4	V	
Maximum Continuous Drain-Source Diode Forward Current		I_S				12	A	
Maximum Pulsed Drain-Source Diode Forward Current		I_{SM}				48	A	
Reverse Recovery Time		t_{rr}	$V_{GS}=0V, I_S=12A, dI_F/dt=100\text{ A}/\mu\text{s}$ (Note 1)		570		ns	
Reverse Recovery Charge		Q_{RR}			5.5		μC	

Notes: 1. Pulse Test: Pulse width $\leq 300\mu\text{s}$, Duty cycle $\leq 2\%$.
2. Essentially independent of operating temperature.

TEST CIRCUITS AND WAVEFORMS

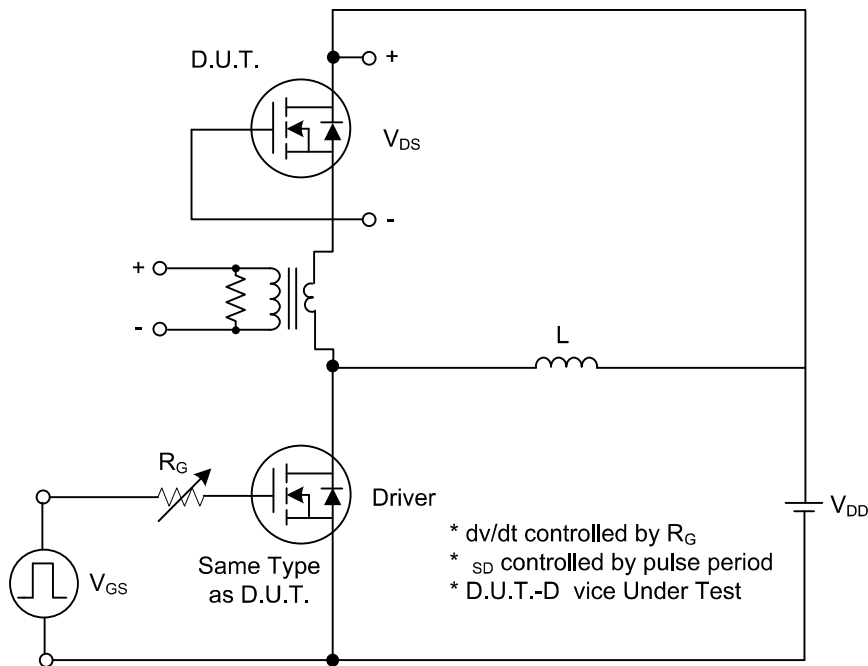

Peak Diode Recovery dv/dt Test Circuit

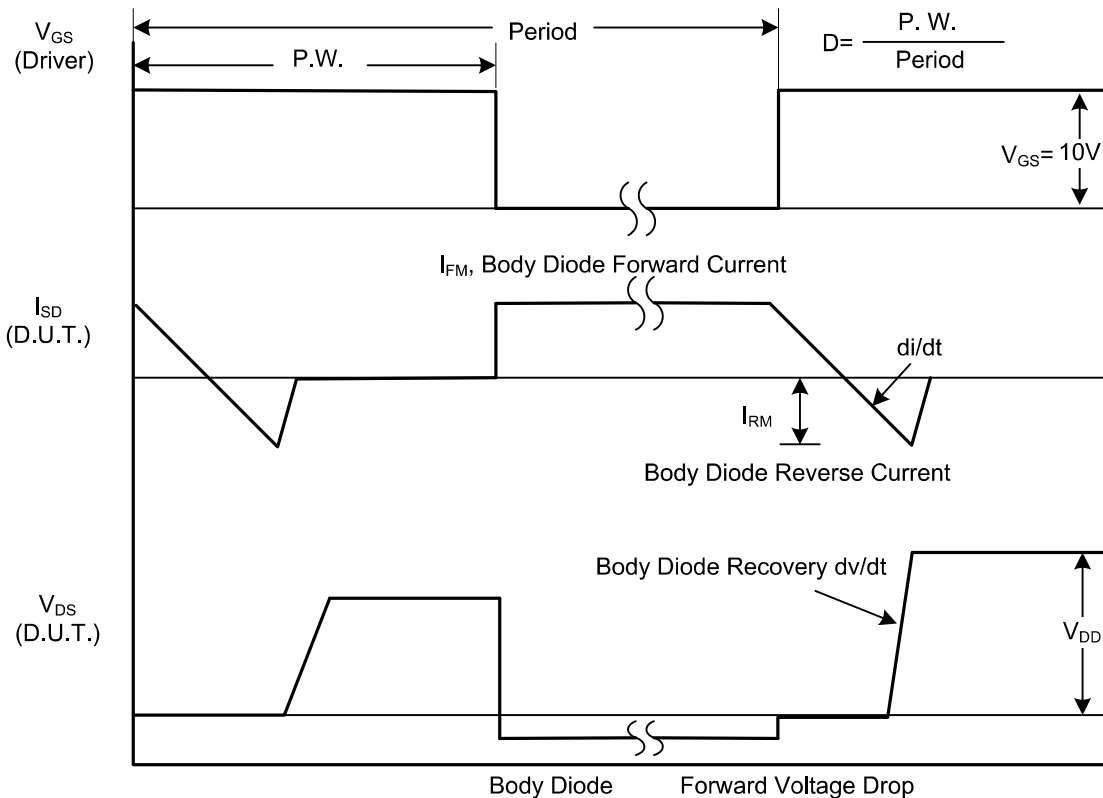

Peak Diode Recovery dv/dt Waveforms

TEST CIRCUITS AND WAVEFORMS(Cont.)

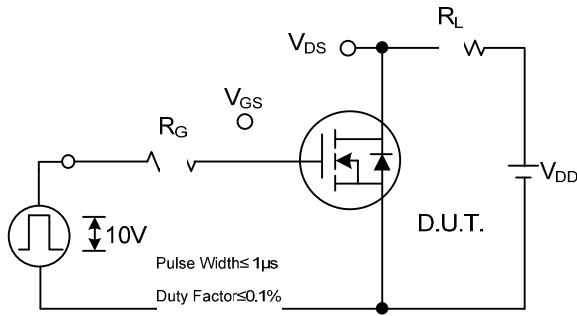

Switching Test Circuit

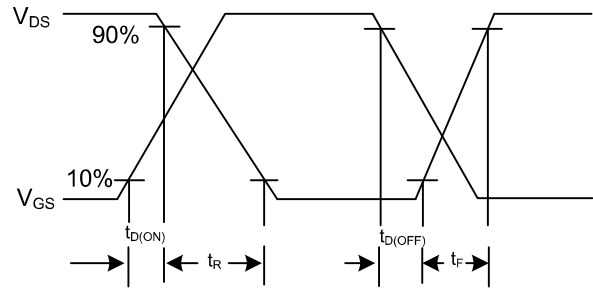

Switching Waveforms

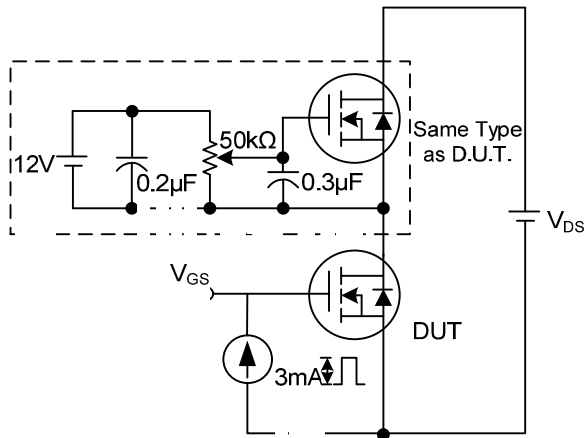

Gate Charge Test Circuit

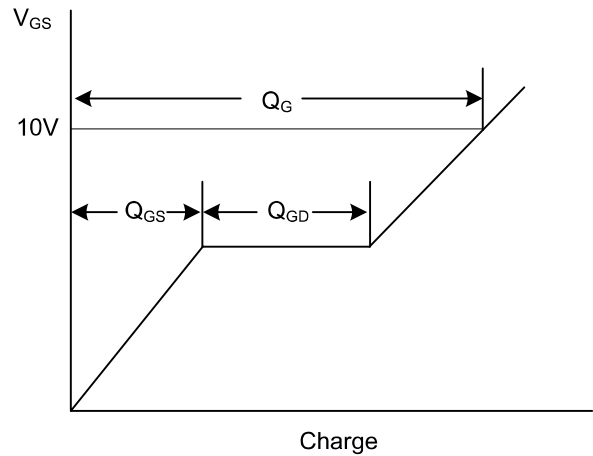

Gate Charge Waveform

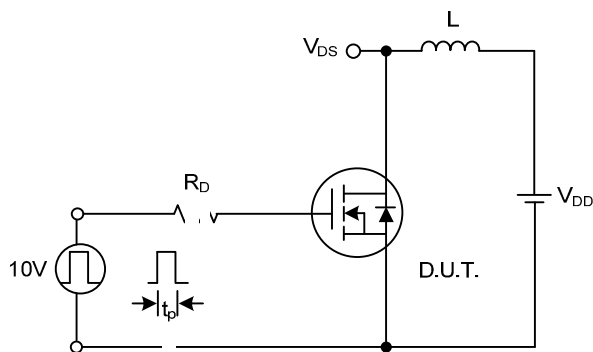

Unclamped Inductive Switching Test Circuit

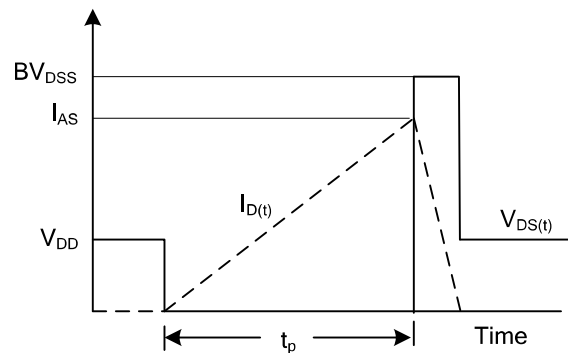

Unclamped Inductive Switching Waveforms

TYPICAL CHARACTERISTICS

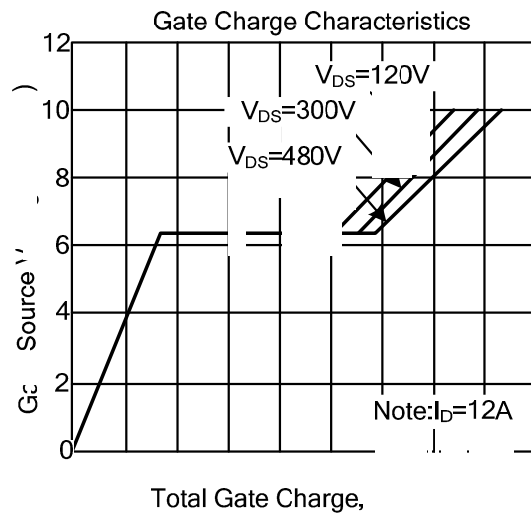
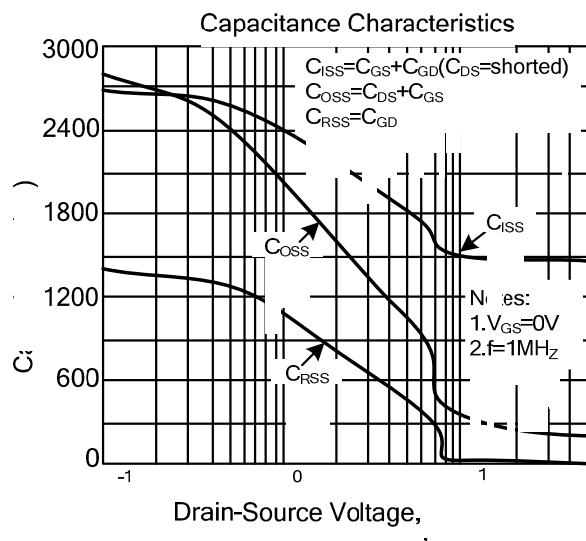
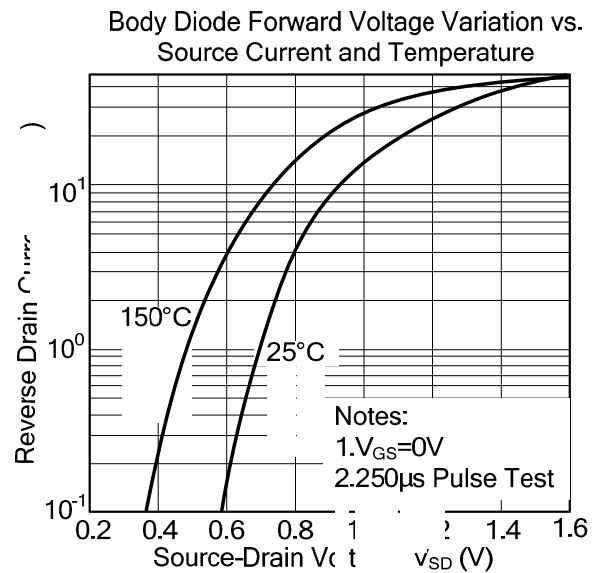
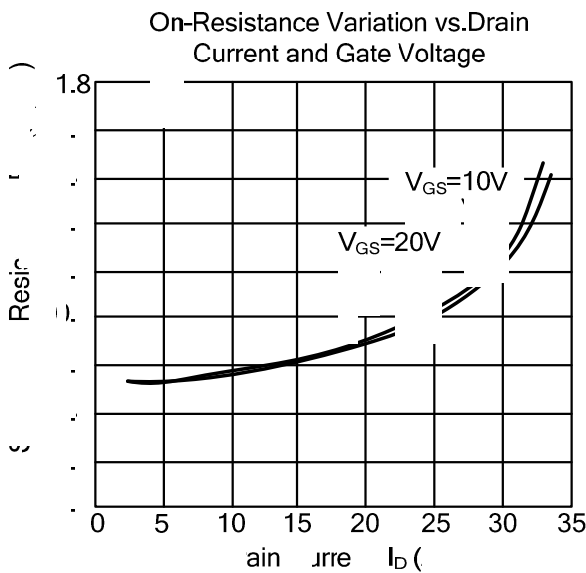
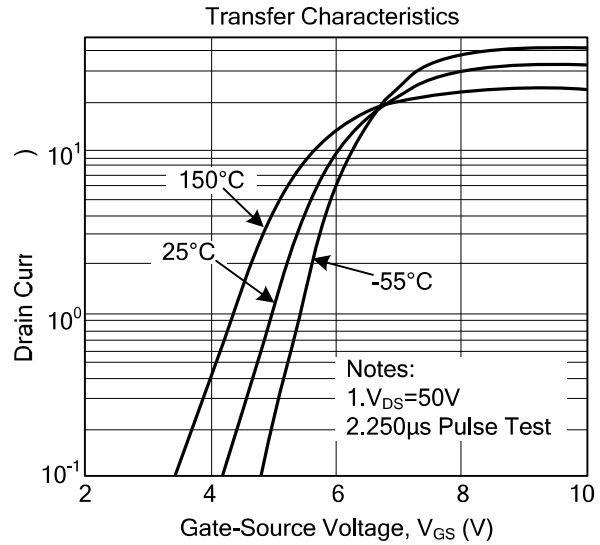
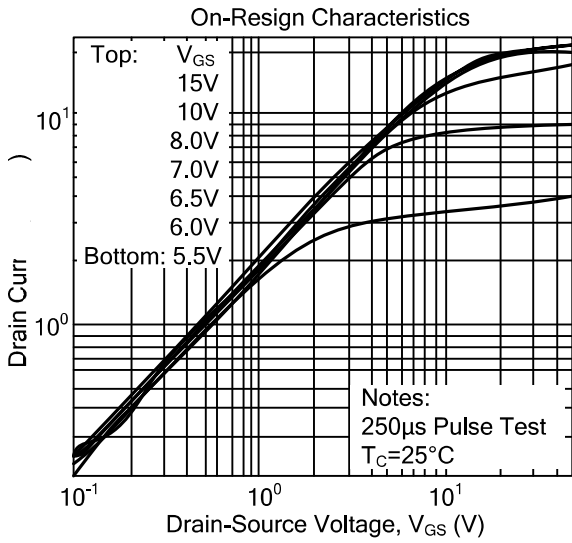

TYPICAL CHARACTERISTICS

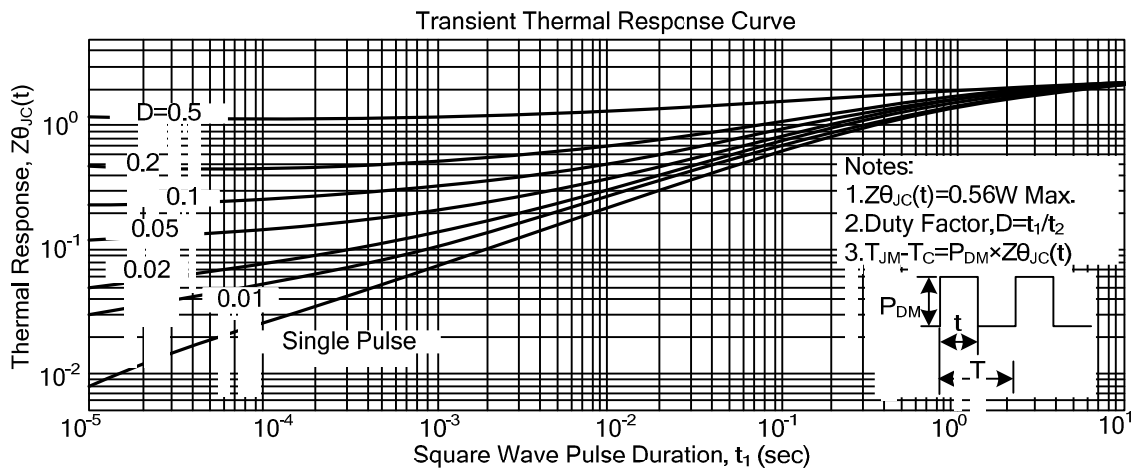
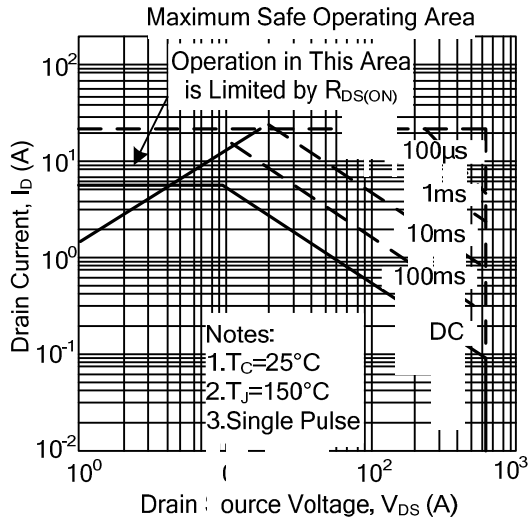

TO-220AB Mechanical Drawing

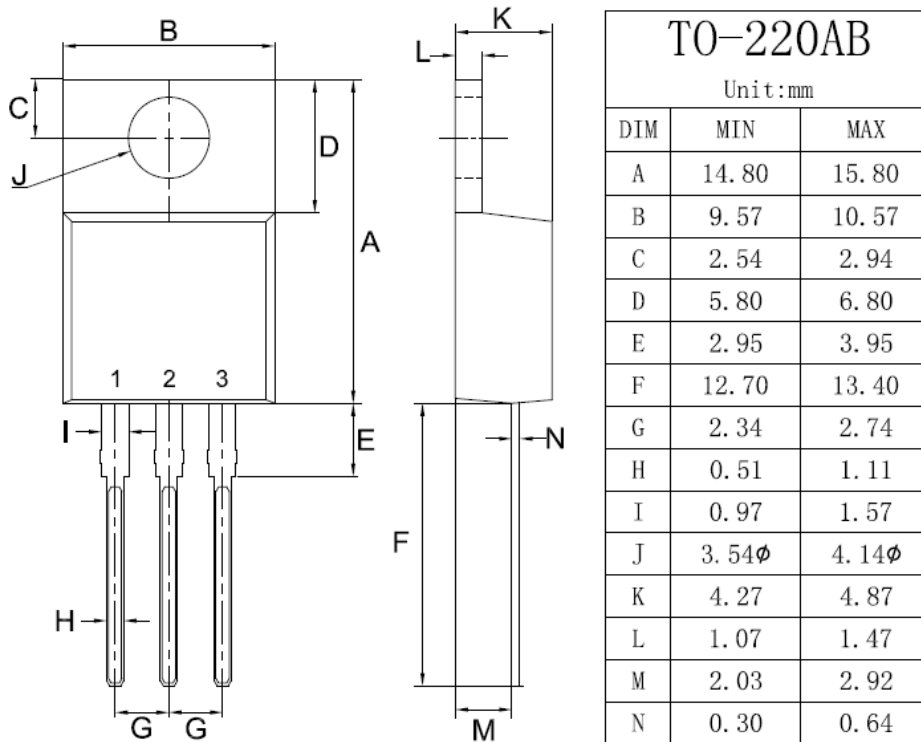

ITO-220AB Mechanical Drawing

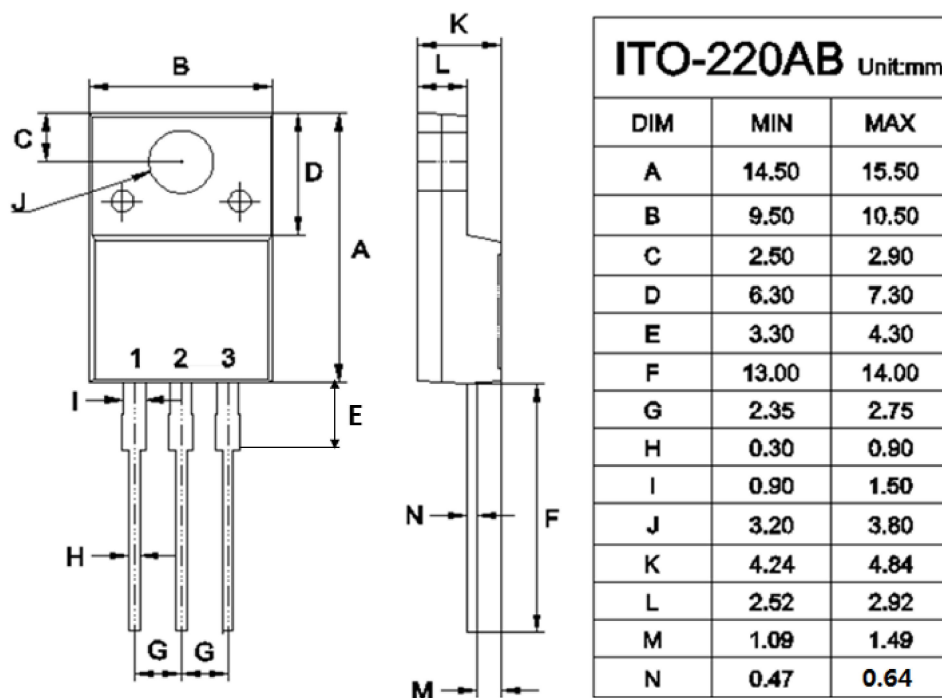

TO-262AB Mechanical Drawing

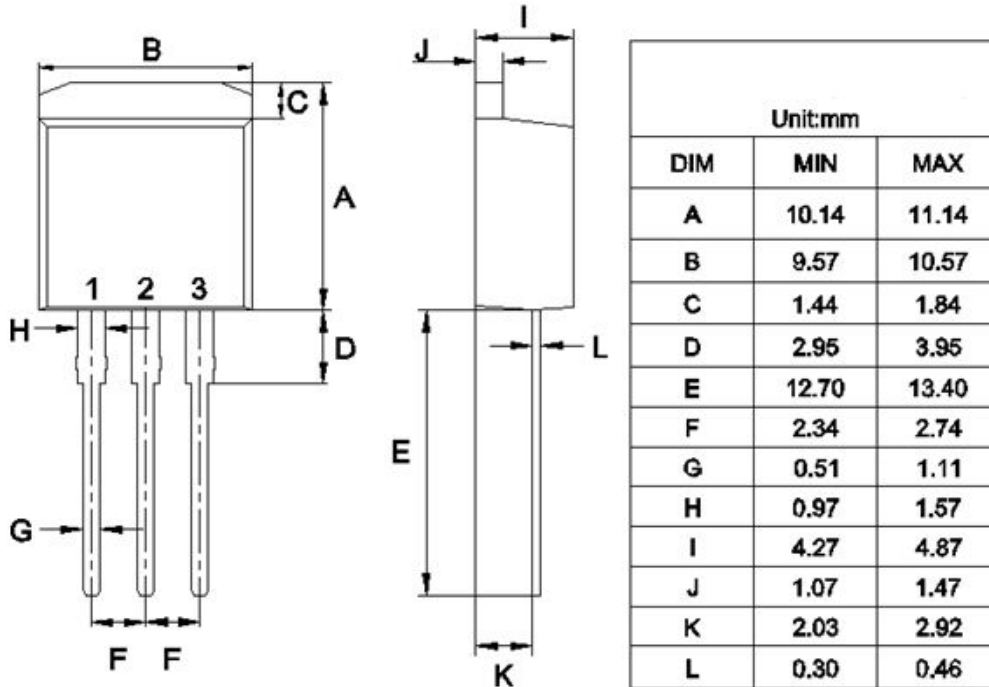

TO-263AB Mechanical Drawing

