

SOT-23 Plastic-Encapsulate MOSFETS

FEATURE

TrenchFET Power MOSFET

APPLICATIONS

- Load Switch for Portable Devices
- DC/DC Converter

MARKING: B00

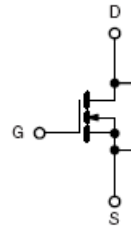

SOT-23

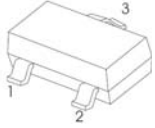
- 
1. GATE
 2. SOURCE
 3. DRAIN

Maximum ratings ($T_a=25^\circ\text{C}$ unless otherwise noted)

Characteristic 特性參數	Symbol 符號	Max 最大值	Unit 單位
Drain-Source Voltage 漏極-源極電壓	BV_{DSS}	30	V
Gate- Source Voltage 柵極-源極電壓	V_{GS}	± 12	V
Drain Current (continuous) 漏極電流-連續	I_D	5	A
Drain Current (pulsed) 漏極電流-脉冲	I_{DM}	18	A
Total Device Dissipation 總耗散功率 $T_A=25^\circ\text{C}$ 環境溫度為 25°C	P_D	1400	mW
Junction 結溫	T_J	150	$^\circ\text{C}$
Storage Temperature 儲存溫度	T_{stg}	-55to+150	$^\circ\text{C}$

SOT-23 Plastic-Encapsulate MOSFETS

Electrical characteristics ($T_a=25^{\circ}\text{C}$ unless otherwise noted)

Characteristic 特性參數	Symbol 符號	Min 最小值	Typ 典型值	Max 最大值	Unit 單位
Drain-Source Breakdown Voltage 漏極-源極擊穿電壓($I_D=250\mu\text{A}, V_{GS}=0\text{V}$)	BV_{DSS}	30	—	—	V
Gate Threshold Voltage 柵極開啓電壓($I_D=250\mu\text{A}, V_{GS}=V_{DS}$)	$V_{GS(th)}$	0.6	—	2	V
Diode Forward Voltage Drop 內附二極管正向壓降($I_S=1.25\text{A}, V_{GS}=0\text{V}$)	V_{SD}	—	0.7	1	V
Zero Gate Voltage Drain Current 零柵壓漏極電流($V_{GS}=0\text{V}, V_{DS}=30\text{V}$)	I_{DSS}	—	—	1	μA
Gate Body Leakage 柵極漏電流($V_{GS}=\pm 12\text{V}, V_{DS}=0\text{V}$)	I_{GSS}	—	—	± 100	nA
Static Drain-Source On-State Resistance 靜態漏源導通電阻($I_D=5\text{A}, V_{GS}=10\text{V}$)	$R_{DS(on)}$	—	35	41	$\text{m}\Omega$
Static Drain-Source On-State Resistance 靜態漏源導通電阻($I_D=3.5\text{A}, V_{GS}=4.5\text{V}$)	$R_{DS(on)}$	—	40	45	$\text{m}\Omega$
Static Drain-Source On-State Resistance 靜態漏源導通電阻($I_D=3\text{A}, V_{GS}=2.5\text{V}$)	$R_{DS(on)}$	—	50	55	$\text{m}\Omega$
Input Capacitance 輸入電容 ($V_{GS}=0\text{V}, V_{DS}=15\text{V}, f=1\text{MHz}$)	C_{ISS}	—	545	—	pF
Output Capacitance 輸出電容 ($V_{GS}=0\text{V}, V_{DS}=15\text{V}, f=1\text{MHz}$)	C_{OSS}	—	66	—	pF
Turn-ON Time 開啓時間 ($V_{DS}=15\text{V}, V_{GS}=10\text{V}, R_{GEN}=6\Omega$)	$t_{(on)}$	—	9.6	—	ns
Turn-OFF Time 關斷時間 ($V_{DS}=15\text{V}, V_{GS}=10\text{V}, R_{GEN}=6\Omega$)	$t_{(off)}$	—	39	—	ns

Pulse Width $\leq 300 \mu\text{s}$; Duty Cycle $\leq 2.0\%$

SOT-23 Plastic-Encapsulate MOSFETS

SOT-23 Package Outline Dimensions

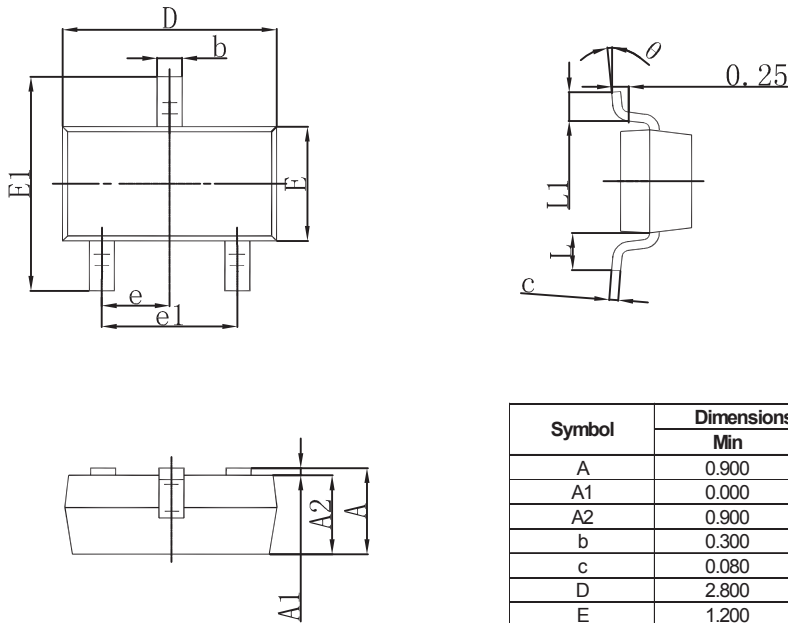

Symbol	Dimensions in Millimeters		Dimensions in Inches	
	Min	Max	Min	Max
A	0.900	1.150	0.035	0.045
A1	0.000	0.100	0.000	0.004
A2	0.900	1.050	0.035	0.041
b	0.300	0.500	0.012	0.020
c	0.080	0.150	0.003	0.006
D	2.800	3.000	0.110	0.118
E	1.200	1.400	0.047	0.055
E1	2.250	2.550	0.089	0.100
e	0.950 TYP		0.037 TYP	
e1	1.800	2.000	0.071	0.079
L	0.550 REF		0.022 REF	
L1	0.300	0.500	0.012	0.020
θ	0°	8°	0°	8°

SOT-23 Suggested Pad Layout

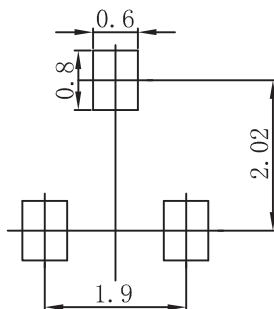

- Note:
1. Controlling dimension: in millimeters.
 2. General tolerance: $\pm 0.05\text{mm}$.
 3. The pad layout is for reference purposes only.