



承認書

SPECIFICATION FOR APPROVAL

客戶名稱

Customer Name

產品名稱 0603 白光

Product Name

產品型號 2SA0603W31C0SW010-1MA

Product No

客戶料號

Customer Part No

適用機型

Model No

日期 2018-05-18

Date

Customer Approved Signatures:

AUTHORIZED	CHECK	VALIDATED

Approved Signatures:

APPROVED	CHECK	PREPARED
洪宗勳	李虎成	刘云珍

Tel/Fax:86-755-6186 5256/ 6186 5258

E-mail:sales@brightekopto.com.

Address 工廠:深圳市寶安區松崗鎮潭頭西部工業園 B7 棟

總部:桃園縣桃園市春日路 1492 號 7 樓



**Part No: 2SA0603W31C0SW010-1MA****Characters**

- § 1.6mm×0.8mm SMT LED , 0.6mm THICKNESS.
- § LOW POWER CONSUMPTION.
- § VIEWING ANGLE 120°.
- § VARIOUS COLORS AND LENS TYPES AVAILABLE.
- § PACKAGE:4000 PCS/REEL.

ITEM	MATERIALS
Resin(Mold)	Epoxy
Lens Color	Yellow
Dice	InGaN
Emitted color	White

Absolute Maximum Ratings (Ta=25°C)

Item	Symbol	Value	Unit
Power Dissipation	PD	100	mW
DC Forward Current	IF	30	mA
Single chip Pulsed Forward Current	IFP	100	mA
Reverse Voltage	VR	5	V
Operating Temperature	Topr	-40 ~ +85	°C
Storage Temperature	Tstg	-40 ~ +85	°C
Soldering Temperature	Tsol	260°C for 5 Seconds	°C

Electrical-Optical Characteristics (Ta=25°C)

Parameter	Symbol	Value			Unit	Test condition
		Min.	Typ.	Max.		
Forward Voltage	Vf	2.6	---	2.9	V	If=1mA
Luminous intensity	Iv	14	---	25	mcd	If=1mA
Wavelength	x	0.2813	---	0.3056	---	If=1mA
	y	0.3235	---	0.3715		
Reverse Current	Ir	---	---	10	μA	Vr=5V
Viewing angle	2θ1/2	---	120	---	Deg	If=1mA

1.Luminous intensity (IV) ±10%, Forward Voltage (VF) ±0.1V, Wavelength(X,Y) ±0.01

2.IS standard testing



Range of Bins

VF(V)	2.6-2.7	2.7-2.8	2.8-2.9
IV(mcd)	14-17	17-21	21-25

Color coordinate Comparison

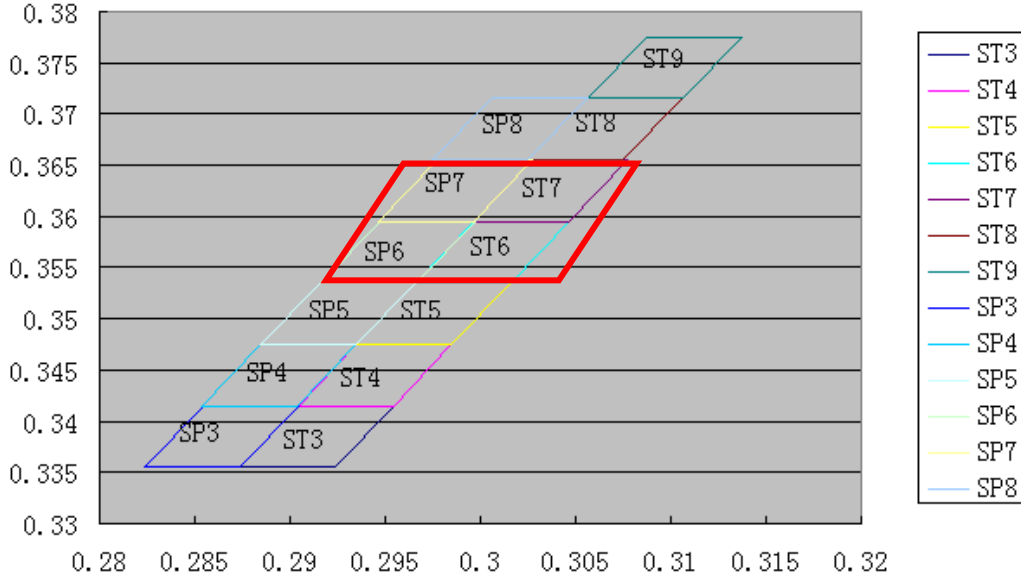

Color Rank

序号	X1	X2	X3	X4	X5	Y1	Y2	Y3	Y4	Y5
ST1	0.2813	0.2844	0.2894	0.2863	0.2813	0.3235	0.3295	0.3295	0.3235	0.3235
ST2	0.2844	0.2874	0.2924	0.2894	0.2844	0.3295	0.3355	0.3355	0.3295	0.3295
ST3	0.2874	0.2905	0.2955	0.2924	0.2874	0.3355	0.3415	0.3415	0.3355	0.3355
ST4	0.2905	0.2935	0.2985	0.2955	0.2905	0.3415	0.3475	0.3475	0.3415	0.3415
ST5	0.2935	0.2966	0.3016	0.2985	0.2935	0.3475	0.3535	0.3535	0.3475	0.3475
ST6	0.2966	0.2996	0.3046	0.3016	0.2966	0.3535	0.3595	0.3595	0.3535	0.3535
ST7	0.2996	0.3027	0.3077	0.3046	0.2996	0.3595	0.3655	0.3655	0.3595	0.3595
ST8	0.3025	0.3056	0.3106	0.3075	0.3025	0.3655	0.3715	0.3715	0.3655	0.3655
ST9	0.3056	0.3087	0.3137	0.3106	0.3056	0.3715	0.3775	0.3775	0.3715	0.3715
SP3	0.2824	0.2855	0.2905	0.2874	0.2824	0.3355	0.3415	0.3415	0.3355	0.3355
SP4	0.2854	0.2885	0.2935	0.2904	0.2854	0.3415	0.3475	0.3475	0.3415	0.3415
SP5	0.2885	0.2916	0.2966	0.2935	0.2885	0.3475	0.3535	0.3535	0.3475	0.3475
SP6	0.2916	0.2947	0.2997	0.2966	0.2916	0.3535	0.3595	0.3595	0.3535	0.3535
SP7	0.2946	0.2977	0.3027	0.2996	0.2946	0.3595	0.3655	0.3655	0.3595	0.3595
SP8	0.2975	0.3006	0.3056	0.3025	0.2975	0.3655	0.3715	0.3715	0.3655	0.3655



Outline Dimensions

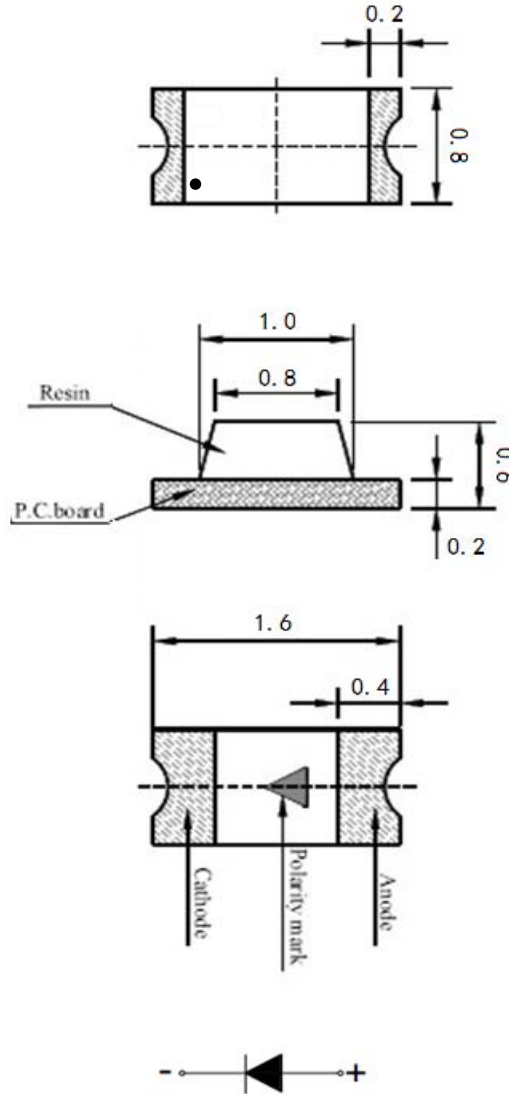

RECOMMEND PAD LAYOUT

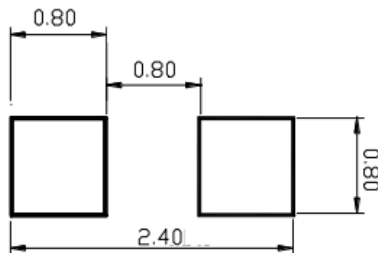

- § All dimensions are in millimeters (inches) .
- § Tolerance is ± 0.1 (.004) mm unless otherwise noted.
- § Specifications are subject to change without notice.



Electrical characteristic graph

1).Relative Spectral Distribution

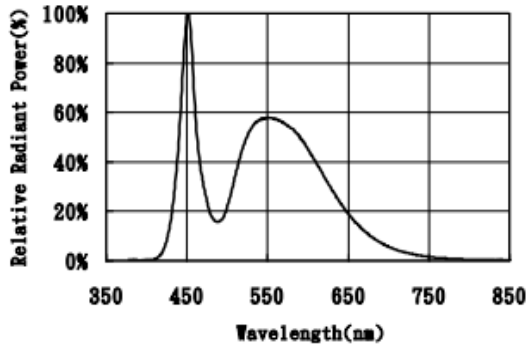

2).Typical Spatial Distribution

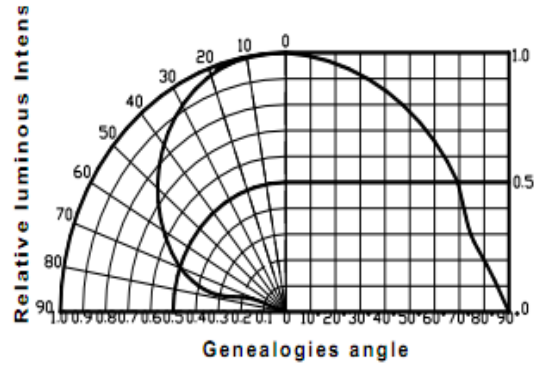

3).Relative Luminous Intensity .Current

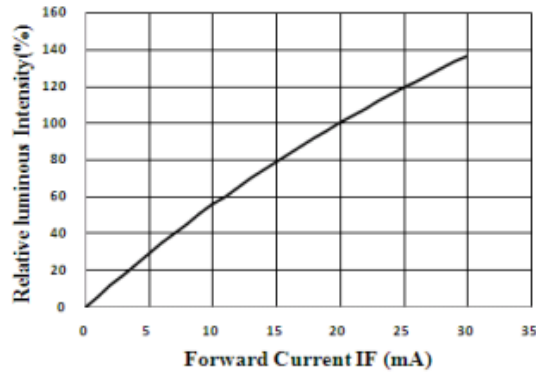

4).Relative Luminous Flux .Ambient Temperature

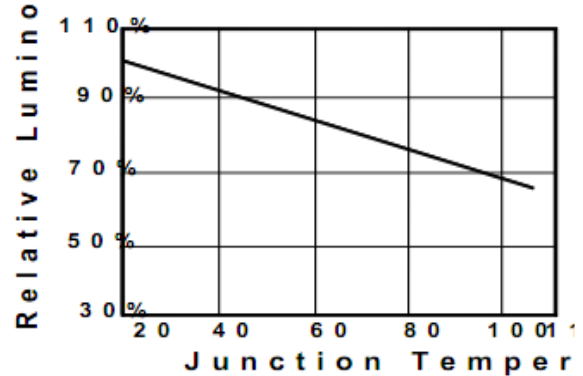

5).Electrical Characteristics

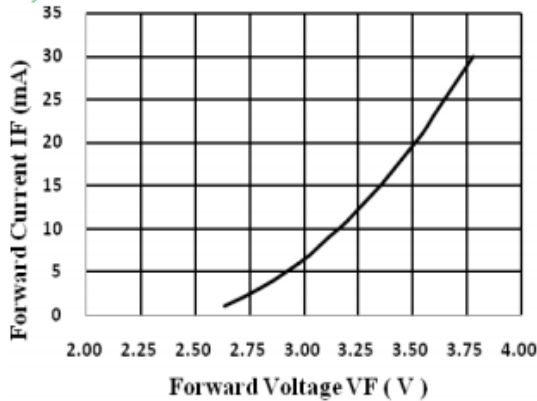

6).Forward Voltage Temperature

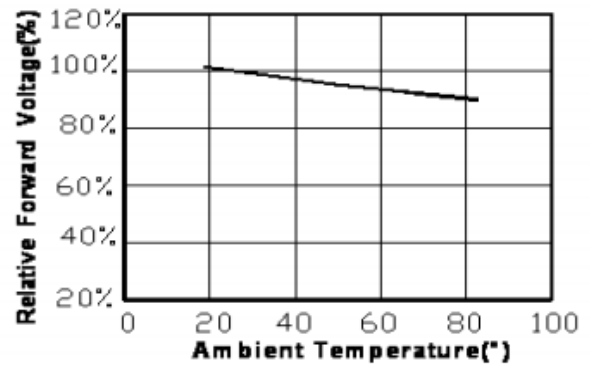

7).Relative Emission Efficiency. Current

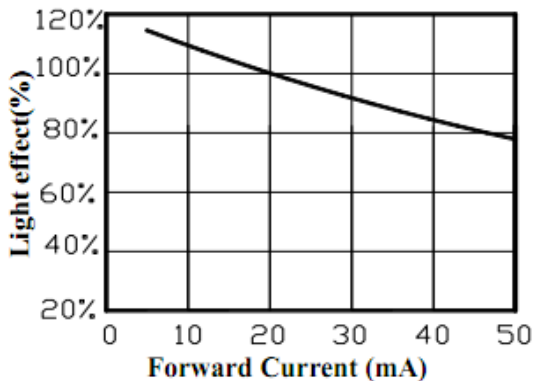

8).Thermal Design

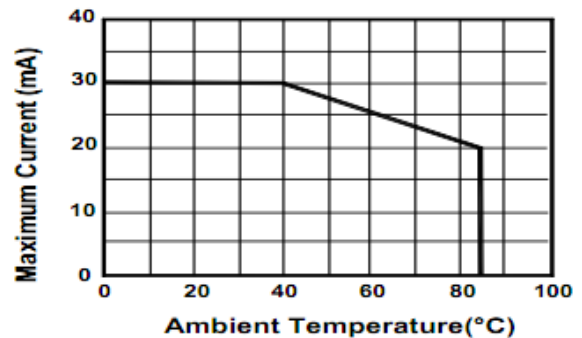



SMD 類物料存儲及使用說明

一、存儲說明：

- (1) LED 使用密封防潮靜電袋包裝，並附有乾燥劑，出貨前均有烘烤除濕，並抽真空包裝。開封前，產品須存放在溫度 $25\pm 5^{\circ}\text{C}$ ，相對濕度 40-70%RH 環境中。
- (2) 禁止把倒放出來的乾燥劑置於潮濕的地方，所使用的乾燥劑應立即投入所放置的產品中裡面去，並立即密封好產品的封口，餘下的乾燥劑就用繩子紮緊袋口，並封好外箱，避免空氣進入。
- (3) 乾燥劑在完成密封情況下，自生產日期起開始計算，有效期為 6 個月。
- (4) 開封後，產品應在 24 小時內使用完；如未能使用完，餘料須放置於溫度 $25\pm 5^{\circ}\text{C}$ ，相對濕度 40-70%RH 環境中。濕敏等級較高的產品建議上線前先行 $60^{\circ}\text{C}/12\text{H}$ 烘烤除濕。(建議工作環境為溫度不高於 30°C ，濕度不高於 60%RH。)
- (5) 對於尚未焊接的 LED，如果包裝失效或者產品沒有符合以上有效儲存條件，使用前必須要進行烘烤處理(卷帶包裝產品烘烤條件： 60°C ，持續時間 12 小時，烘烤時包裝袋要取下，放置卷盤的產品烘烤要保證熱風循環，烤箱必須打開排濕口)。
- (6) 生產日期在三個月內，LED 使用前烘烤 $60^{\circ}\text{C}/24$ 小時；生產日期超過三個月至一年內的 LED 使用前烘烤條件： $60^{\circ}\text{C}/36\sim 48$ 小時。
- (7) 如進料前，已發現防潮靜電箔袋拆封、破損、穿孔，可及時退回我司重新進行除濕。在包裝拆封後，對未用完的產品需保存於密封、乾燥的環境下，避免採用透明膠帶、訂書釘進行簡單的封口。如果產品未作嚴格的密封防潮保存，則再次使用前必須進行高溫除濕。

二、使用說明：

- (1) 回流焊接溫度及時間請參照對應產品規格書。LED 不宜進行兩次或兩次以上的回流焊接。
- (2) 不建議將 LED 貼裝在彎曲的線路板上。焊接時避免快速冷卻，在 LED 焊接冷卻過程中避免任何形式的機械力或過度的震動，焊接後不要彎曲線路板。
- (3) 完成焊接的 LED 不宜進行返修作業。如不可避免，採用雙頭烙鐵，但事先應確認返修是否會對 LED 的特性產生破壞。

回流焊曲線圖：

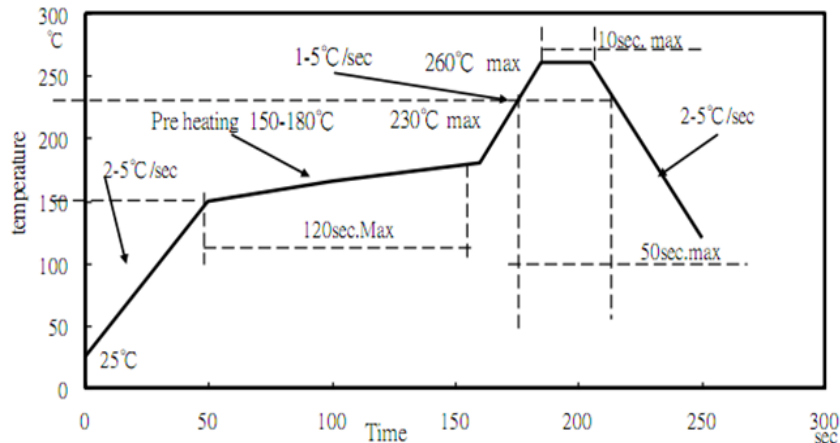

1. 我們建議的回流焊溫度為 $240^{\circ}\text{C}\pm 5^{\circ}\text{C}$ ，最高的焊接溫度要控制在 260°C 以內。
2. 當產品在處在高溫狀態中時不要對其矽膠施加壓力。
3. 回流焊的次數應不超過 1 次。

三、靜電防護：

LED 是靜電敏感電子元器件，應採取各種措施避免靜電，諸如在使用過程中戴靜電手環或防靜電手套。所有的裝置、設備儀器應適當的接地。建議在貼裝 LED 時預防機器設備的浪，建議對組裝後的 LED 產品進行測試檢查 LED 是否受到靜電的破壞，白光或藍光 LED 確認方法為(參考)： 1mA 或 2.5V 單顆晶片不能點亮或同等條件下亮度較其他 LED 明顯偏暗為缺陷品。

四、清潔清洗：

建議使用異丙醇來清潔 LED，如果要採用其他溶劑清潔，一定要確保此溶劑不會對環氧、有機矽、矽膠、支架鍍銀層等產生影響。不建議使用超聲波清洗以免對 LED 造成損傷。若不可避免，清洗前請事先進行預測試，以確認是否對 LED 造成不良影響或潛在性隱患。



Test circuit and handling precautions

1. Test Circuit

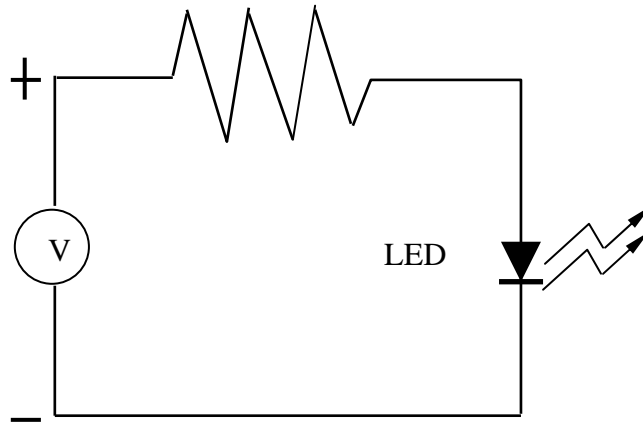

2. Handling Precautions

1. Over-current-proof

Customer must apply resistors for protection; otherwise slight voltage shift will cause big current change (Burn out will happen).

2. Storage

2.1 It is recommended to store the products in the following conditions:

Humidity: 60% R.H. Max.

Temperature: 5°C~30°C (41°F~86°F)

2.2 Shelf life in sealed bag: 12 month at <5°C~30°C and <60% R.H. after the package is

Opened, the products should be used within four week or they should be keeping to stored at $\leq 20\%$ R.H. with zip-lock sealed.

3. Baking

It is recommended to baking before soldering when the pack is unsealed after 24hrs. The

Conditions are as followings:

3.1 60±3°C x 6hrs and <5%RH, for reel

3.2 125±3°C x 2hrs, for single LED

It shall be normal to see slight color fading of carrier (light yellow) after baking in process



0603 SMD Chip LEDs Packaging Specifications

- Feeding Direction

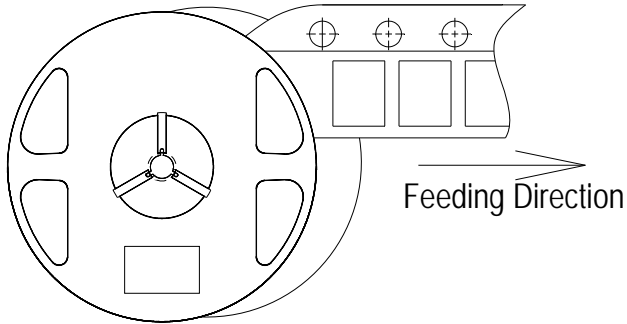

- Dimensions of Reel (Unit: mm)

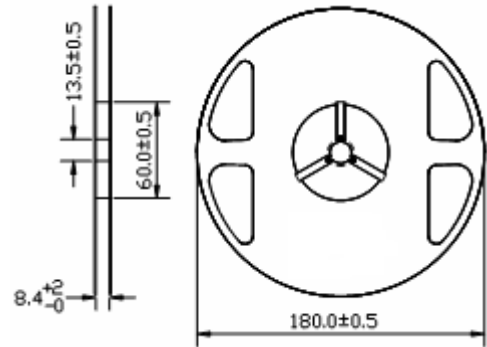

- Dimensions of Tape (Unit: mm)

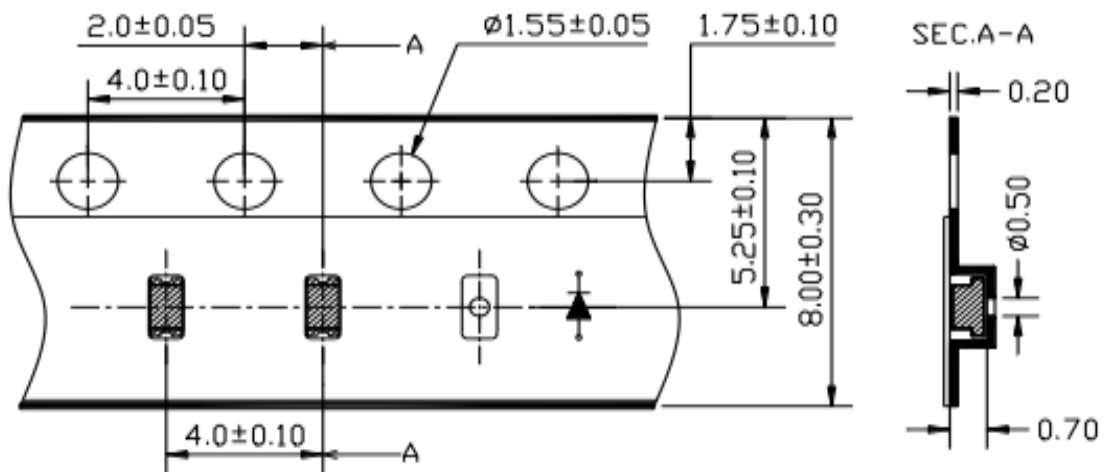

NOTES

1. Empty component pockets are sealed with top cover tape;
2. The maximum number of missing lamps is two;
3. The cathode is oriented towards the tape sprocket hole in accordance with ANSI/EIA RS-481 specifications;
4. 4,000pcs/Reel



0603 SMD Chip LEDs Packaging Specifications

- Packaging specifications

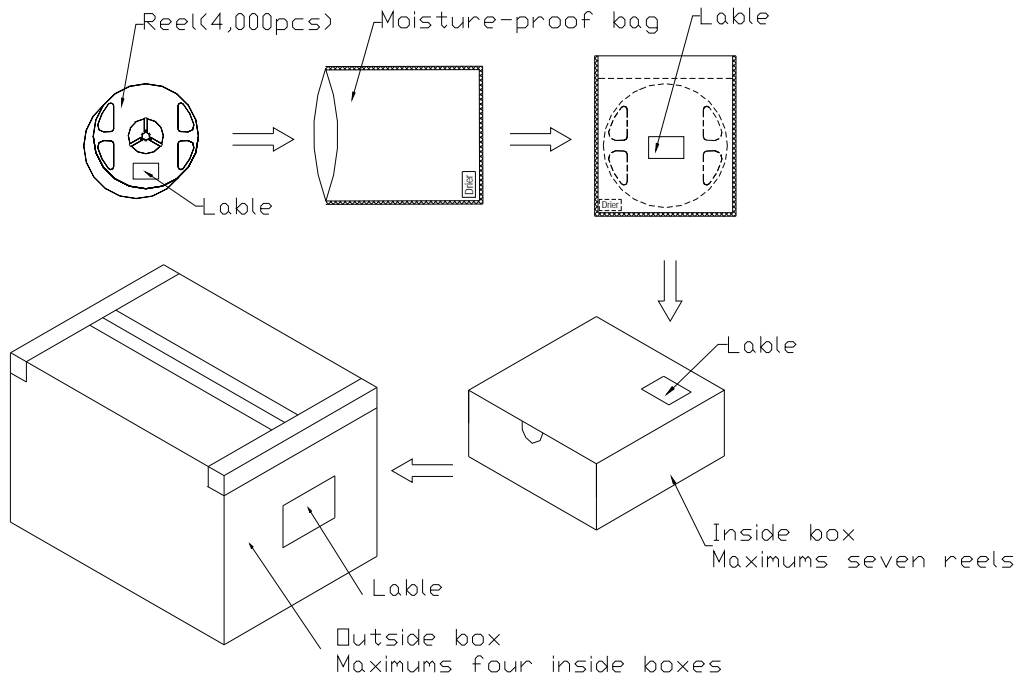

NOTES:

Reeled products (numbers of products are 4,000pcs) packed in a seal off moisture-proof bag along with a desiccant one by one, Seven moisture-proof bag of maximums (total maximum number of products are 28,000pcs) packed in an inside box (size: about 238mm x about 194mm x about 102mm) and four inside boxes of maximums are put in the outside box (size: about 410mm x about 254mm x about 229mm) Together with buffer material, and it is packed. (Part No., Lot No., quantity should appear on the label on the moisture-proof bag, part No. And quantity should appear on theinsection request form on the cardboard box.) .