



承認書

SPECIFICATION FOR APPROVAL

客戶名稱

Customer Name

產品名稱

0603 橙光

Product Name

產品型號

2SA0603A11A0SW001

Product No

客戶料號

Customer Part No

適用機型

Model No

日期

2018-05-18

Date

Customer Approved Signatures:

AUTHORIZED	CHECK	VALIDATED

Approved Signatures:

APPROVED	CHECK	PREPARED
洪宗勳	李虎成	刘云珍

Tel/Fax:86-755-6186 5256/ 6186 5258

E-mail:sales@brightekopto.com.

Address 工廠:深圳市寶安區松崗鎮潭頭西部工業園 B7 棟

總部:桃園縣桃園市春日路 1492 號 7 樓



**Part No: 2SA0603A11A0SW001****Characters**

- § 1.6mm×0.8mm SMT LED , 0.6mm THICKNESS.
- § LOW POWER CONSUMPTION.
- § VIEWING ANGLE 120°.
- § VARIOUS COLORS AND LENS TYPES AVAILABLE.
- § PACKAGE:4000 PCS/REEL.

ITEM	MATERIALS
Resin(Mold)	Epoxy
Lens Color	Yellow
Dice	GaAsP
Emitted color	Orange

Absolute Maximum Ratings (Ta=25°C)

Item	Symbol	Value	Unit
Power Dissipation	PD	80	mW
DC Forward Current	IF	30	mA
Single chip Pulsed Forward Current	IFP	100	mA
Reverse Voltage	VR	5	V
Operating Temperature	Topr	-40 ~ +85	°C
Storage Temperature	Tstg	-40 ~ +85	°C
Soldering Temperature	Tsol	260°C for 5 Seconds	°C

Electrical-Optical Characteristics (Ta=25°C)

Parameter	Symbol	Value			Unit	Test condition
		Min.	Typ.	Max.		
Forward Voltage	Vf	1.9	---	2.2	V	If=5mA
Luminous intensity	Iv	17	---	30	mcd	If=5mA
Wavelength	λd	600	---	608	nm	If=5mA
Reverse Current	Ir	---	---	10	μA	Vr=5V
Viewing angle	2θ1/2	---	120	---	Deg	If=5mA

1.Luminous intensity (IV) ±10%, Forward Voltage (VF) ±0.1V, Wavelength(λd) ±0.5nm

2.IS standard testing

Range of Bins

VF(V)	1.9-2.0	2.0-2.1	2.1-2.2	
IV(mcd)	17-21	21-25	25-30	
WLL(nm)	600-602	602-604	604-606	606-608



Outline Dimensions

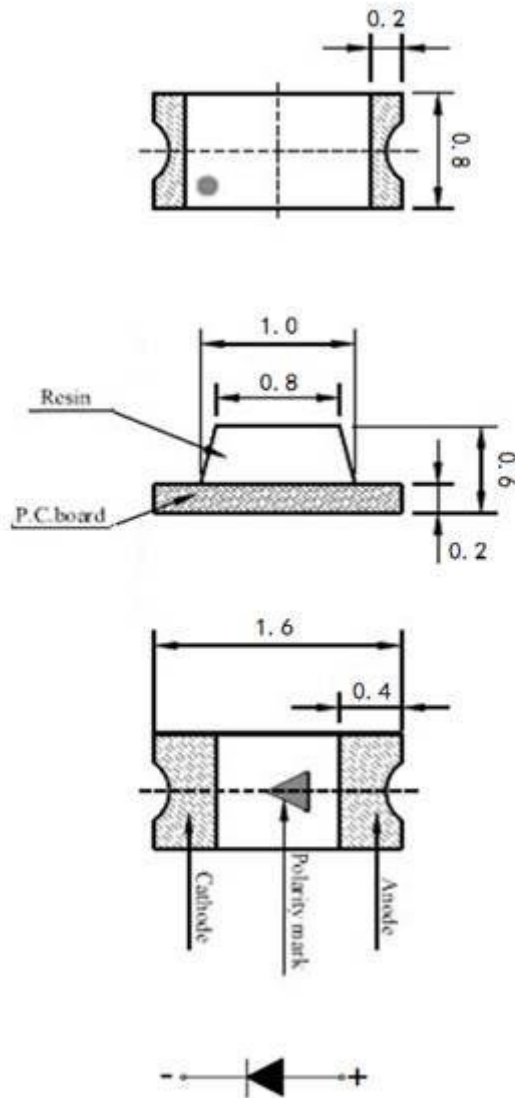

RECOMMEND PAD LAYOUT

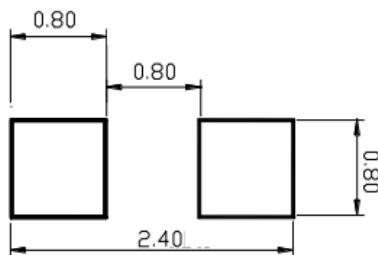

- § All dimensions are in millimeters (inches) .
- § Tolerance is ± 0.1 (.004) mm unless otherwise noted.
- § Specifications are subject to change without notice.



Electrical characteristic graph

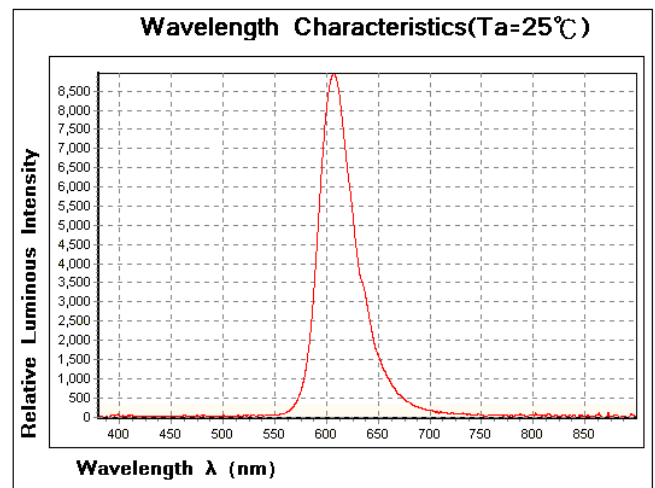
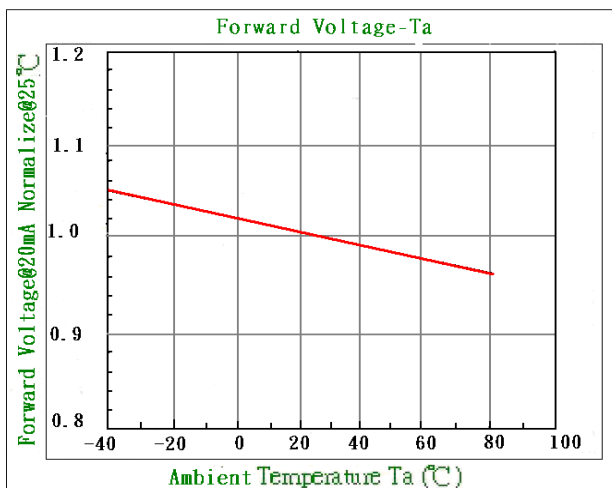
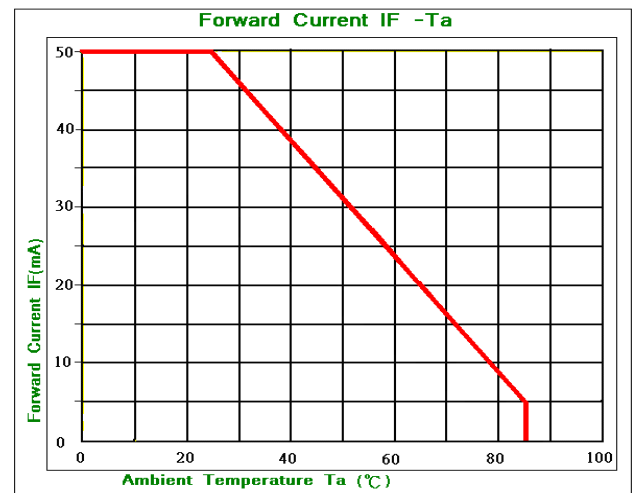
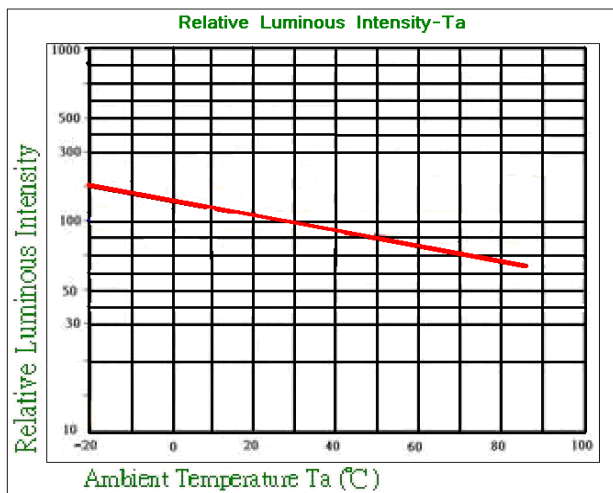
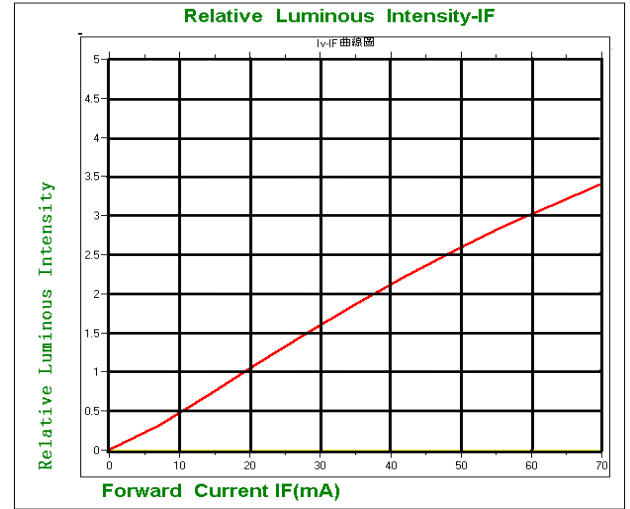
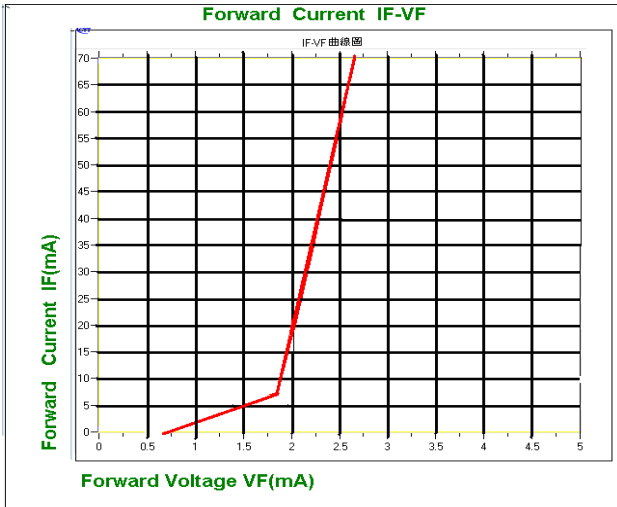



SMD 類物料存儲及使用說明

一、存儲說明：

- (1) LED 使用密封防潮靜電袋包裝，並附有乾燥劑，出貨前均有烘烤除濕，並抽真空包裝。開封前，產品須存放在溫度 $25\pm 5^{\circ}\text{C}$ ，相對濕度 40-70%RH 環境中。
- (2) 禁止把倒放出來的乾燥劑置於潮濕的地方，所使用的乾燥劑應立即投入所放置的產品中裡面去，並立即密封好產品的封口，餘下的乾燥劑就用繩子紮緊袋口，並封好外箱，避免空氣進入。
- (3) 乾燥劑在完成密封情況下，自生產日期起開始計算，有效期為 6 個月。
- (4) 開封後，產品應在 24 小時內使用完；如未能使用完，餘料須放置於溫度 $25\pm 5^{\circ}\text{C}$ ，相對濕度 40-70%RH 環境中。濕敏等級較高的產品建議上線前先行 $60^{\circ}\text{C}/12\text{H}$ 烘烤除濕。(建議工作環境為溫度不高於 30°C ，濕度不高於 60%RH。)
- (5) 對於尚未焊接的 LED，如果包裝失效或者產品沒有符合以上有效儲存條件，使用前必須要進行烘烤處理(卷帶包裝產品烘烤條件： 60°C ，持續時間 12 小時，烘烤時包裝袋要取下，放置卷盤的產品烘烤要保證熱風循環，烤箱必須打開排濕口)。
- (6) 生產日期在三個月內，LED 使用前烘烤 $60^{\circ}\text{C}/24$ 小時；生產日期超過三個月至一年內的 LED 使用前烘烤條件： $60^{\circ}\text{C}/36\sim 48$ 小時。
- (7) 如進料前，已發現防潮靜電箔袋拆封、破損、穿孔，可及時退回我司重新進行除濕。在包裝拆封後，對未用完的產品需保存於密封、乾燥的環境下，避免採用透明膠帶、訂書釘進行簡單的封口。如果產品未作嚴格的密封防潮保存，則再次使用前必須進行高溫除濕。

二、使用說明：

- (1) 回流焊接溫度及時間請參照對應產品規格書。LED 不宜進行兩次或兩次以上的回流焊接。
- (2) 不建議將 LED 貼裝在彎曲的線路板上。焊接時避免快速冷卻，在 LED 焊接冷卻過程中避免任何形式的機械力或過度的震動，焊接後不要彎曲線路板。
- (3) 完成焊接的 LED 不宜進行返修作業。如不可避免，採用雙頭烙鐵，但事先應確認返修是否會對 LED 的特性產生破壞。

回流焊曲線圖：

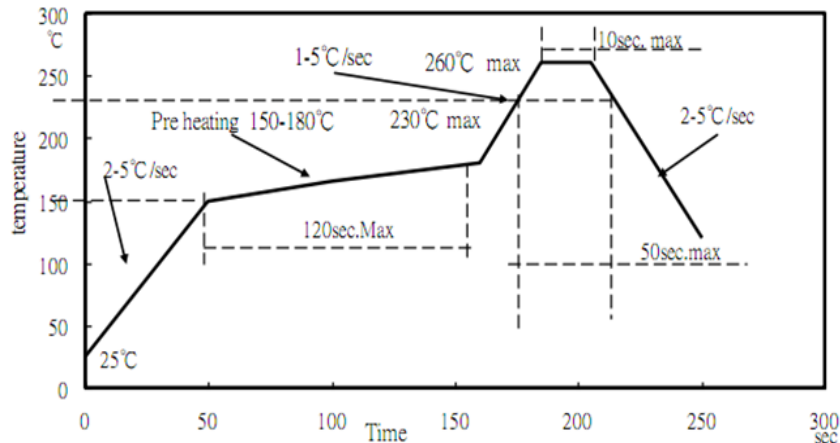

1. 我們建議的回流焊溫度為 $240^{\circ}\text{C}\pm 5^{\circ}\text{C}$ ，最高的焊接溫度要控制在 260°C 以內。
2. 當產品在處在高溫狀態中時不要對其矽膠施加壓力。
3. 回流焊的次數應不超過 1 次。

三、靜電防護：

LED 是靜電敏感電子元器件，應採取各種措施避免靜電，諸如在使用過程中戴靜電手環或防靜電手套。所有的裝置、設備儀器應適當的接地。建議在貼裝 LED 時預防機器設備的浪，建議對組裝後的 LED 產品進行測試檢查 LED 是否受到靜電的破壞，白光或藍光 LED 確認方法為(參考)：1mA 或 2.5V/單顆晶片不能點亮或同等條件下亮度較其他 LED 明顯偏暗為缺陷品。

四、清潔清洗：

建議使用異丙醇來清潔 LED，如果要採用其他溶劑清潔，一定要確保此溶劑不會對環氧、有機矽、矽膠、支架鍍銀層等產生影響。不建議使用超聲波清洗以免對 LED 造成損傷。若不可避免，清洗前請事先進行預測試，以確認是否對 LED 造成不良影響或潛在性隱患。



Test circuit and handling precautions

1. Test Circuit

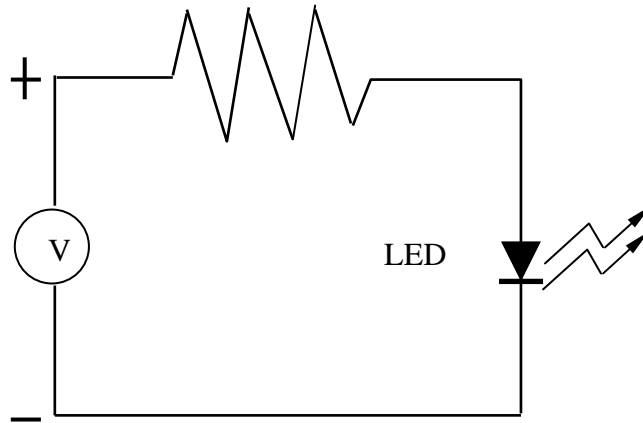

2. Handling Precautions

1. Over-current-proof

Customer must apply resistors for protection; otherwise slight voltage shift will cause big current change (Burn out will happen).

2. Storage

2.1 It is recommended to store the products in the following conditions:

Humidity: 60% R.H. Max.

Temperature: 5°C~30°C (41°F~86°F)

2.2 Shelf life in sealed bag: 12 month at <5°C~30°C and <60% R.H. after the package is

Opened, the products should be used within four week or they should be keeping to stored at $\leq 20\%$ R.H. with zip-lock sealed.

3. Baking

It is recommended to baking before soldering when the pack is unsealed after 24hrs. The

Conditions are as followings:

3.1 60 \pm 3°C x 6hrs and <5%RH, for reel

3.2 125 \pm 3°C x 2hrs, for single LED

It shall be normal to see slight color fading of carrier (light yellow) after baking in process



0603 SMD Chip LEDs Packaging Specifications

● Feeding Direction

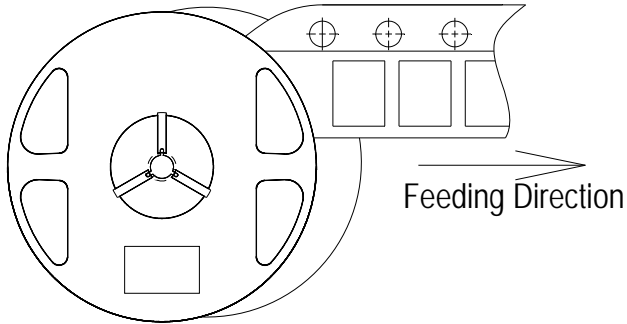

● Dimensions of Reel (Unit: mm)

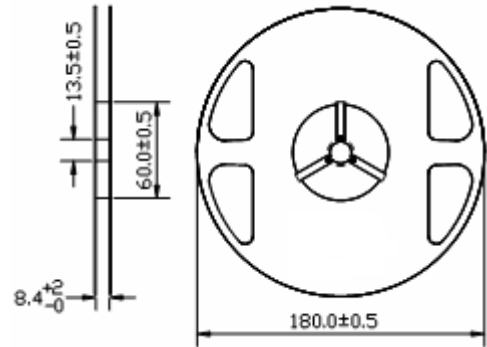

● Dimensions of Tape (Unit: mm)

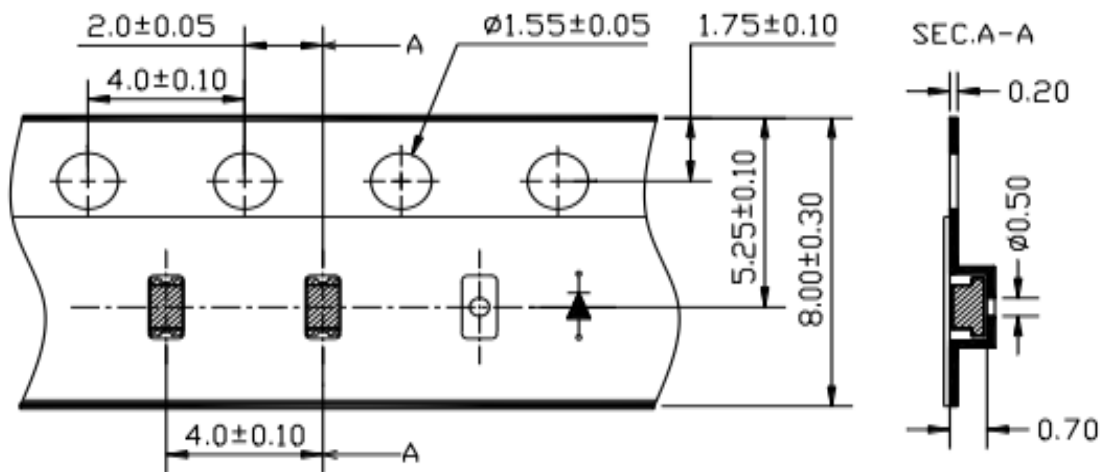

NOTES

1. Empty component pockets are sealed with top cover tape;
2. The maximum number of missing lamps is two;
3. The cathode is oriented towards the tape sprocket hole in accordance with ANSI/EIA RS-481 specifications;
4. 4,000pcs/Reel



0603 SMD Chip LEDs Packaging Specifications

- Packaging specifications

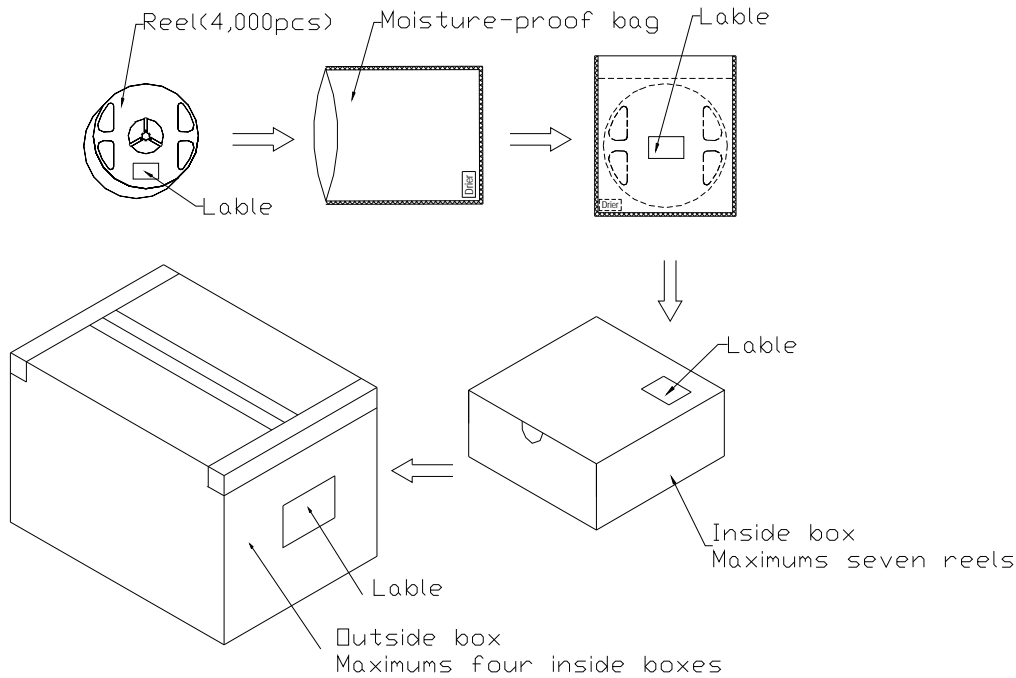

NOTES:

Reeled products (numbers of products are 4,000pcs) packed in a seal off moisture-proof bag along with a desiccant one by one, Seven moisture-proof bag of maximums (total maximum number of products are 28,000pcs) packed in an inside box (size: about 238mm x about 194mm x about 102mm) and four inside boxes of maximums are put in the outside box (size: about 410mm x about 254mm x about 229mm) Together with buffer material, and it is packed. (Part No., Lot No., quantity should appear on the label on the moisture-proof bag, part No. And quantity should appear on theinsection request form on the cardboard box.) .