

项目	零件名称	数量	材质	处理/备注
1	SHELL	1	STAINLESS	Ni:50u"
2	Molding HOUSING	2	L.C.P	(Black)
3	GND SPRING	2	STAINLESS	Ni:50u"
4	Insert molding 12PIN	2	L.C.P	(Black)
5	CONTACT	24	COPPER ALLOY	Contact area: gold flash, Solder tails: Tm100u", Ni:50u"
6	PCB	1		

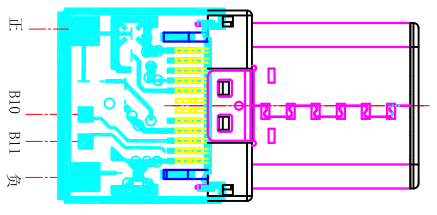
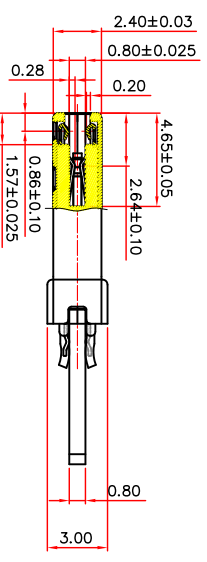
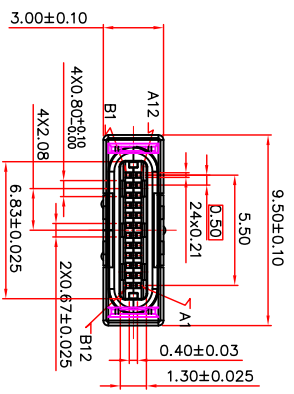
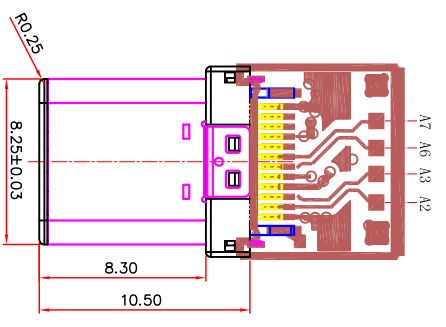

**SPECIFICATION**

**MATERIAL**

See drawing  
**STANDARD DATA**  
Operating temperature: -10°C ~ +60°C  
Storage temperature: -20°C ~ +85°C

**ELECTRICAL**

Insulator resistance: 100Mohms Min.  
Withstanding voltage: 100 VAC / minute  
Contact resistance: initial 40mohms Max;  
after 50mohms Max.

**MECHANICAL**

Mating force: 5~20N  
Umating force : 8~20N  
Durability: 5000 cycles Min.

深圳市精拓金电子有限公司

公差一览表 TOLERANCE UNLESS OTHERWISE		单位 UNITS	MM	制图 DRAWING	Z-Y-B	产品料号 PRODUCT PART NO.	产品名称 PRODUCT NAME	角法 VIEW	版本 VERSION
X	±0.25	X'	±5'	审核			USB-3.1 公头/双面PCB板3.0	⊕	A0
.X	±0.20	.X'	±2'	核准				⊕	
.XX	±0.15	.XX'	±1'					⊕	
.XXX	±0.10	.XXX'	±0.5'					⊕	
日期 DATE		2015.07.14		核准 APPD					

产品图  
PRODUCT CHART DWG

