

1.1 Product Name

KH-1110-UB8X

1.2 Product Description

Featuring a single die solution, low power consumption and low costs, the KH-1110-UB8X are multi-GNSS (GPS, BeiDou, GLONASS, SBAS and QZSS) positioning Module developed to meet the requirements of an extensive range of applications and end-products. Based on the high performance UBX-M8030 position engine, these receivers provide exceptional sensitivity and acquisition times and interference suppression measures enable reliable positioning even in difficult signal conditions.

1.3 Product Features

- UBX-M8030 high performance GPS/GNSS Chips:
 - over 2 million effective correlators
 - 72 channels in Search mode
 - cold start acquisition sensitivity of -148 dBm and -167 dBm tracking sensitivity
 - up to 10 Hz navigation update rate
- Supports GPS, QZSS, GLONASS, BeiDou and is ready for Galileo
- Supports AGPS
- Integrated TCXO, LNA, SAW, RTC
- Compact size (10mm x 9.7mm x 2.3mm) suitable for space-sensitive application
- Support standard NMEA 0183, version 2.3 and 4.1, UBX, RTCM

1.4 Product Application

- Handheld GPS receiver application
- Ideal for PDA, Pocket PC
- Geographic Surveying
- Sports and Recreation
- Marine Navigation, Fleet Management
- Automotive application
- Car navigation and tracking
- AVL and Location-Based Services
- Timing application
- UAV

1.5 Performance

Parameter	Specification
Receiver type	<ul style="list-style-type: none"> <li style="width: 25%;">■GPS L1 C/A <li style="width: 25%;">■SBAS L1 C/A <li style="width: 25%;">■QZSS L1 C/A <li style="width: 25%;">■GLONASS L1OF <li style="width: 25%;">□BeiDou B1 <li style="width: 25%;">□Galileo E1B/C²
Sensitivity	<ul style="list-style-type: none"> Tracking & Navigation: -167dBm Reacquisition: -163dBm Cold Start: -148dBm
Time-To-First-Fix ¹	<ul style="list-style-type: none"> Cold Start 29 s Warm Start 28 s Hot Start 1 s
Horizontal Position accuracy ²	<ul style="list-style-type: none"> Autonomous 2.5 m SBAS 2.0 m
Accuracy of time pulse signal	RMS 30 ns
Velocity accuracy	0.1 m/s
Operational limits ³	<ul style="list-style-type: none"> Dynamics ≤ 4 g Altitude 50000 m Velocity 500 m/s
Frequency of time pulse signal	0.25 Hz ... 10 MHz
Baud Rate	9,600 bps (Default)
Max navigation update rate	10Hz (Default 1Hz)

¹ All satellites at -130 dBm

² CEP, 50%, 24 hours static, -130 dBm, > 6

³ SVs Assuming Airborne < 4 g platform

1.6 Block Diagram

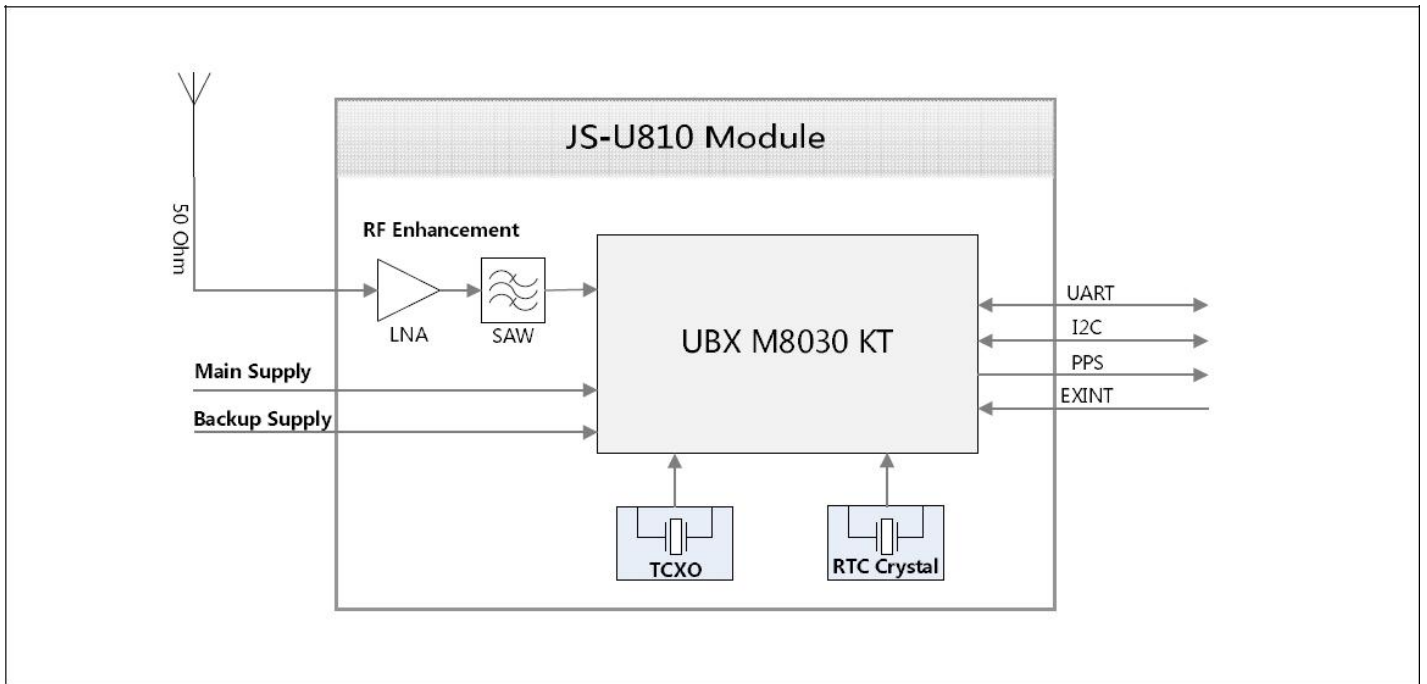

1.7 Protocols

Protocol	Type
NMEA 0183, version 2.3 and 4.1	Input/output, ASCII
UBX	Input/output, binary, u-blox proprietary
RTCM	Input, messages 1, 2, 3, 9

1.8 Interfaces

1.8.1 UART, I2C

The KH-1110-UB8X module includes I2C, UART interface, which can be used for communication to a host. It supports configurable baud rates.

1.9 Antenna

The KH-1110-UB8X module was designed for use with passive and active antennas.

Parameter	Specification
	Minimum gain 15 dB (to compensate signal loss in RF cable)
Active Antenna Recommendations	Maximum gain 30 dB
	Maximum noise figure 1.5 dB

2.1 Product Picture

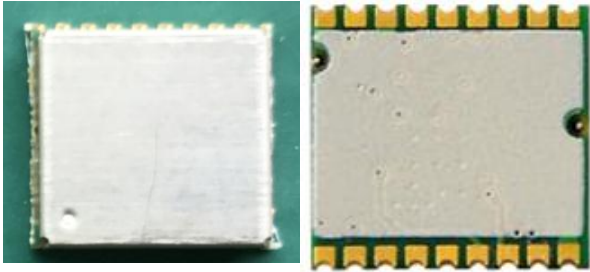

2.2 Definition of Pin Assignment

10	GND	RESET	9
11	RF_IN	VCC	8
12	GND	NC	7
13	NC	V_backup	6
14	VCC_RF	EXTINT	5
15	NC	1PPS	4
16	NC	RXD	3
17	NC	TXD	2
18	NC	GND	1

No.	Name	I/O	Description
1,10,12	GND	G	Ground
2	TXD	O	TTL output (keep open if not used)
3	RXD	I	TTL Input (keep open if not used)
4	1PPS	O	Time Pulse (keep open if not used)
5	EXINT	I	External Interrupt Pin (keep open if not used)
6	V_backup	I	Backup voltage supply
7,13,15,16,17,18	VCC_IO	I	NC (keep open if not used)
8	VCC	I	Main Supply
9	RESET	I	RESET_N (Active low, keep open if not used)
11	RF_IN	I	GNSS Signal Input
14	VCC_RF		Output Voltage RF section (keep open if not used)

2.3 Electrical Specification

Parameter	Symbol	Min	Typ	Max	Units
Power supply voltage	VCC	2.8	3.3	3.6	V
Average supply current	Acquisition	41@3.3V	45@3.3V	49@3.3V	mA
	Tracking	40@3.3V	43@3.3V	47@3.3V	mA
Backup battery voltage	V_BCKP	2.8	3.3	3.6	V
Backup battery current	I_BCKP		8@3.3V		uA
Digital IO voltage	Div	2.26		3.18	V
Storage temperature	Tstg	-40		85	°C
Operating temperature	Topr	-40		85	°C
Humidity				95	%

2.4 Mechanical Specification

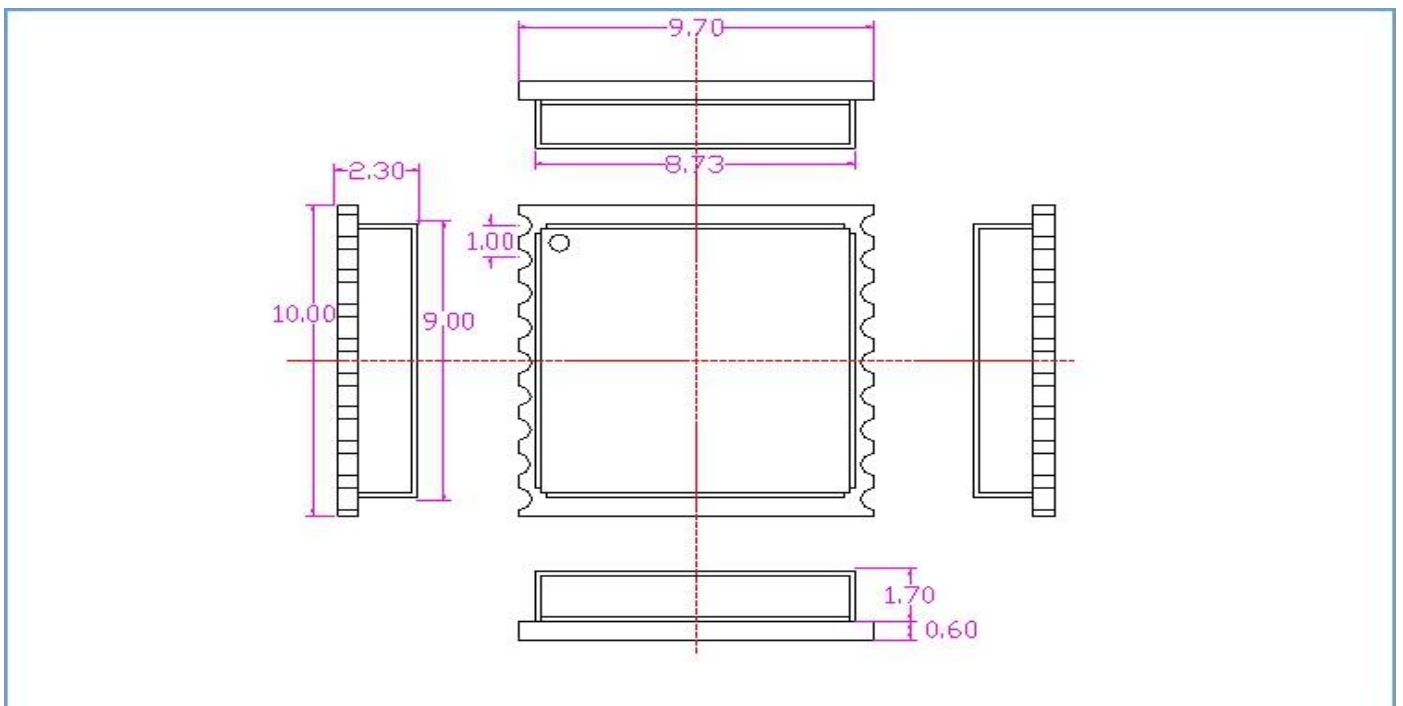

units:mm dimension error ± 0.2 mm

2.5 Application Circuit

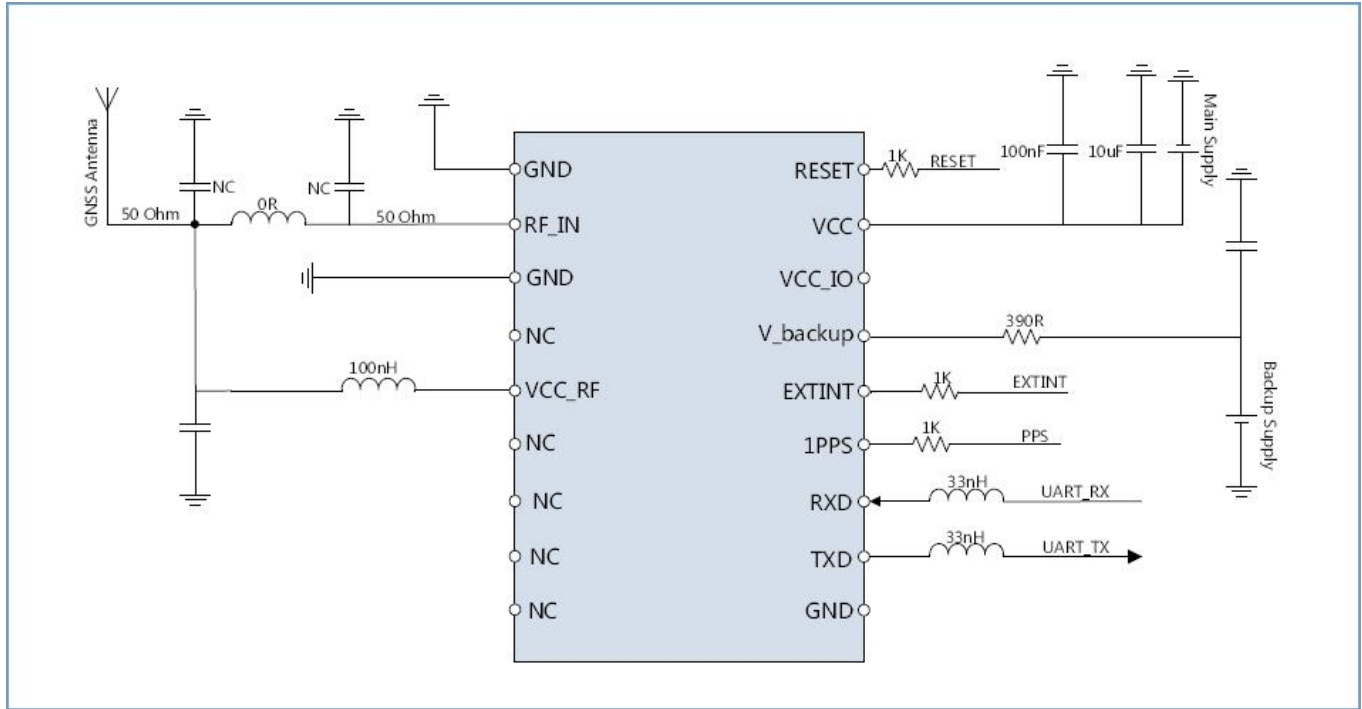

2.6 RoHS Compliance

This product is RoHS compliance

2.7 Recommended Reflow Profile (If need)

Temperature[°C]

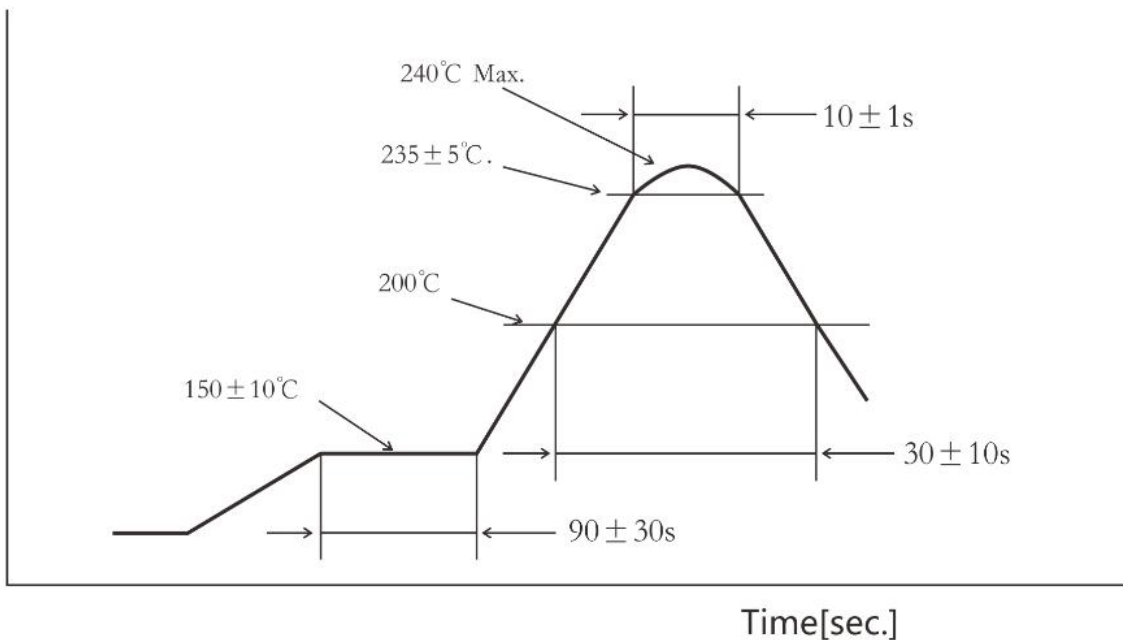

3.1 GNSS module before the SMT note:

3.1.1 When customers Open stencil must be sure the hole bigger to the GNSS module plate, please press 1 to 1 and 0.7 mm is widened to open outward, the thickness of 0.12 mm.

3.1.2 Can't get the GNSS module bare hands when needs ,must we wear the gloves and static ring.

3.1.3 The furnace temperature according to the size of the customer the mainboard ,generally like to stick on a tablet standard temperature of 250 + - 5,can do 260 + - 5.

3.2 Storage and use GNSS module control should pay attention to the following matters:

3.2.1 Storage life: 12 months. Storage conditions:<40°C . Relative humidity:<90%R.H.

3.2.2 After this bag is opened , devices that will be subjected to infrared reflow, vapor-phase reflow, or equivalent processing must be:

3.2.3 Check the humidity card :stored at $\leq 20\%$ RH.If :30%~40%(pink)or greater than 40%(red).Labeling module has moisture absorption.

3.2.4 Mounthed within 168 hours at factory conditions of: $t \leq 30^\circ\text{C}$, $\leq 60\%$ R.H.

3.2.5 Once opened, the workshop the preservation of life for 168 hours.

3.3 If baking is required, devices may be baked for:

3.3.1 Modules must be to remove module moisture problem.

3.3.2 Baking temperature: 125 °C, 8 hours.

3.3.3 After baking, put proper amount of desiccant to seal packages.

3.4 The actual number of module vacuum packing which is based on the actual number of packages to the customer requirements.

3.5 Module reel packaging items as follows.

3.5.1 Storage life: 12 months. Storage conditions:<40°C . Relative humidity:<90%R.H.

3.5.2 Module apart packing after 168 hours, To launch patch need to bake, to remove the module hygroscopic, baking temperature conditions: 125°C, 8hours.

3.5.3 The actual number of module reel packing which is based on the actual number of packages to the customer requirements.

3.6 Module pallet packaging items as follows:

3.6.1 Storage life: 3 months. Storage conditions:<40°C . Relative humidity:<90%R.H.

3.6.2 Module if not used within 48 hours, before launch the need for baking, baking temperature: 125 °C, 8 hours.

3.6.3 Pallet packaging each plate is 100 PCS. The actual number of module pallet packing which is based on the actual number of packages to the customer requirements.