

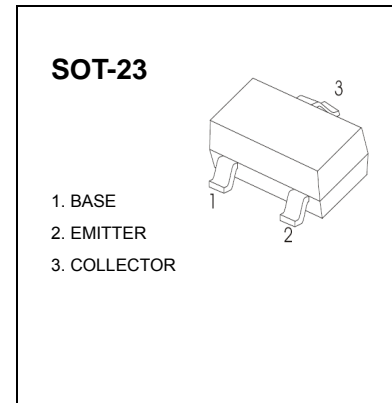

BC846A, B TRANSISTOR (NPN)
BC847A, B, C
BC848A, B, C

FEATURES

- Ideally suited for automatic insertion
- For Switching and AF Amplifier Applications



MAXIMUM RATINGS (T_a=25°C unless otherwise noted)

Symbol	Parameter	Value	Unit
V _{CB0}	Collector-Base Voltage	BC846	80
		BC847	50
		BC848	30
V _{CEO}	Collector-Emitter Voltage	BC846	65
		BC847	45
		BC848	30
V _{EBO}	Emitter-Base Voltage	6	V
I _C	Collector Current –Continuous	0.1	A
P _{C*}	Collector Power Dissipation	200	mW
T _J	Junction Temperature	150	°C
T _{stg}	Storage Temperature	-65-150	°C

DEVICE MARKING

BC846A=1A; BC846B=1B;
BC847A=1E; BC847B=1F; BC847C=1G;
BC848A=1J; BC848B=1K; BC848C=1L



ELECTRICAL CHARACTERISTICS (T_a=25°C unless otherwise specified)

Parameter	Symbol	Test conditions	Min	Typ	Max	Unit
Collector-base breakdown voltage	BC846	$I_C = 10\mu A, I_E = 0$	80			V
	BC847		50			
	BC848		30			
Collector-emitter breakdown voltage	BC846	$I_C = 10mA, I_B = 0$	65			V
	BC847		45			
	BC848		30			
Emitter-base breakdown voltage		$I_E = 10\mu A, I_C = 0$	6			V
Collector cut-off current	BC846	I_{CBO}	$V_{CB} = 70V, I_E = 0$		0.1	μA
	BC847		$V_{CB} = 50V, I_E = 0$			
	BC848		$V_{CB} = 30V, I_E = 0$			
Collector cut-off current	BC846	I_{CEO}	$V_{CE} = 60V, I_B = 0$		0.1	μA
	BC847		$V_{CE} = 45V, I_B = 0$			
	BC848		$V_{CE} = 30V, I_B = 0$			
Emitter cut-off current		I_{EBO}	$V_{EB} = 5V, I_C = 0$		0.1	μA
DC current gain	BC846A,847A,848A	h_{FE}	$V_{CE} = 5V, I_C = 2mA$	110	220	
	BC846B,847B,848B			200	450	
	BC847C,BC848C			420	800	
Collector-emitter saturation voltage		$V_{CE(sat)}$	$I_C = 100mA, I_B = 5mA$		0.5	V
Base-emitter saturation voltage		$V_{BE(sat)}$	$I_C = 100mA, I_B = 5mA$		1.1	V
Transition frequency		f_T	$V_{CE} = 5V, I_C = 10mA$ $f = 100MHz$	100		MHz
Collector output capacitance		C_{ob}	$V_{CB} = 10V, f = 1MHz$		4.5	pF