

### 1. External Dimensions (Unit:m/m)

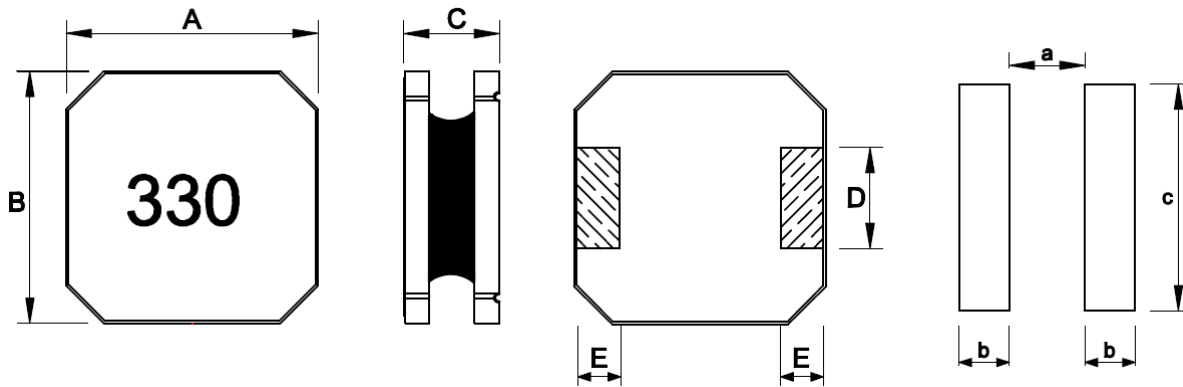

Type	A	B	C	D	E	a	b	c	Q'TY/Reel
ABG10A50	10.0±0.2	10.0±0.2	5.1Max	4.2Ref	1.7Ref	6.2Ref	2.0Ref	5.5Ref	700

### 2. Part Number Code

$\frac{ABG}{A}$      $\frac{10}{B}$      $\frac{A}{C}$      $\frac{50}{D}$      $\frac{M}{E}$      $\frac{330}{F}$

A: Series Name                      Power Inductors  
 B: Dimensions(mm)                10: 10.0x10.0  
 C: Materials                          NO use  
 D: Thickness(mm)                  50: 5.1 Max  
 E: Tolerance                          M:±20%  
 F: Inductance                        330=33uH

### 3. Electrical Characteristics

Part Number	Inductance (μH)	Test Frequency (KHz)	DC Resistance (mΩ)±30%	Heat Rating Current Irms (A)	Saturation Current Isat (A)
ABG10A50M330	33.0	100KHz/1V	71.0	3.5	5.2

Notes:

- All test data is referenced to 25°C ambient.
- Operating Temperature Range-40°C to +125°C.
- Irms: DC current(A)that will cause an approximate ΔT of 40°C.
- Isat: DC current(A)that will cause Lo to drop approximately 40%.
- The part temperature(ambient + temp rise)should not exceed 125°C under worst case operating conditions. Circuit design,component placement, PWB trace size and thickness,airflow and other cooling provisions all affect the part temperature. Part temperature should be verified in the end application.

### 4. Material List

No	Item	Material	Supplier	UL NO.
1	CORE	N401H SDR-10-4.8-5.2-2.6S	CYOR EQUIVALENT	N/A
2	WIRE	UEWH/U2	PEWC OR EQUIVALENT	E201757
3	Epoxy	DA-1001BK/E-500AH(BLACK)	CHOR EQUIVALENT	N/A

### 5. Test Data

ELECTRICAL CHARACTERISTIC				MECHANICAL DIMENSIONS				
SPEC	L(uH)	DCR(mΩ)	Isat(uH)	A(mm)	B(mm)	C(mm)	D(mm)	
TOL	33.0	71.0	5.2A	10.0	10.0	5.1	4.2	
NO	±20%	±30%	(LOA-L5.2A) /LOA≤40%	±0.2	±0.2	Max	Ref	
1	30.83	68.83	20.95	10.01	10.03	4.86	OK	
2	30.96	69.07	20.92	10.02	9.98	4.88	OK	
3	30.58	70.65	21.88	10.01	10.00	4.89	OK	
4	31.12	71.74	21.27	10.03	10.03	4.88	OK	
5	31.29	71.94	21.13	9.99	9.99	4.87	OK	
6	30.54	68.17	20.95	10.00	10.03	4.87	OK	
7	30.65	70.89	20.89	10.03	9.96	4.88	OK	
8	31.13	71.04	21.17	10.02	10.00	4.86	OK	
9	31.07	69.66	21.18	10.00	10.02	4.89	OK	
10	31.19	71.79	21.12	9.98	10.06	4.86	OK	

Test Equipmets:CD1063、CD1320、CD1068、502BC

Curve:

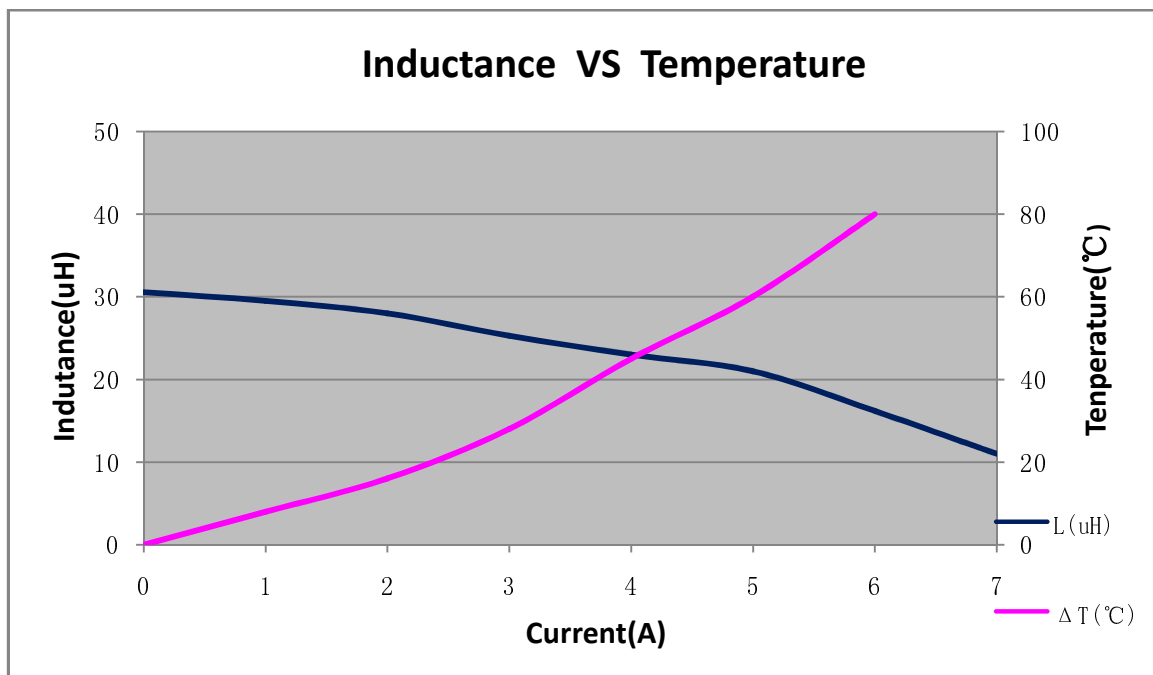

## 6. Test and Measurement Procedures

### 6.1 Test Conditions

6.1.1 Unless otherwise specified, the standard atmospheric conditions for measurement/test as:

- Ambient Temperature:  $20 \pm 15^\circ\text{C}$
- Relative Humidity:  $65\% \pm 20\%$
- Air Pressure: 86KPa to 106KPa

6.1.2 If any doubt on the results, measurements/tests should be made within the following limits:

- Ambient Temperature:  $20 \pm 2^\circ\text{C}$
- Relative Humidity:  $65\% \pm 5\%$
- Air Pressure: 86KPa to 106KPa

### 6.2 Visual Examination

- Inspection Equipment: 10X magnifier

### 6.3 Electrical Test

6.3.1 Inductance (L)

- Refer to the third item.
- Test equipment: CD1063 LCR meter or equivalent.
- Test Frequency and Voltage: Refer to the third item

6.3.2 Direct Current Resistance (DCR)

- Refer to the third item
- Test equipment: 502BC or equivalent.

6.3.3 Saturation Current ( $I_{\text{sat}}$ )

- Refer to the third item
- Test equipment: Saturation current meter
- Definition of saturation current ( $I_{\text{sat}}$ ): DC current at which the inductance drops approximate 40% from its value without current.

6.3.4 Temperature rise current ( $I_{\text{rms}}$ )

- Refer to the third item.
- Test equipment (see Fig.5.3.4-1): Electric Power, Electric current meter, Thermometer.
- Measurement method (see Fig. 6.3.4-1):
  - Set test current to be 0mA.
  - Measure initial temperature of choke surface.
  - Gradually increase current and measure choke temperature for corresponding current.
  - Definition of Temperature rise current: DC current that causes the temperature rise ( $\Delta T = 40^\circ\text{C}$ ) from  $20^\circ\text{C}$  ambient (see Fig. 6.3.4-2).

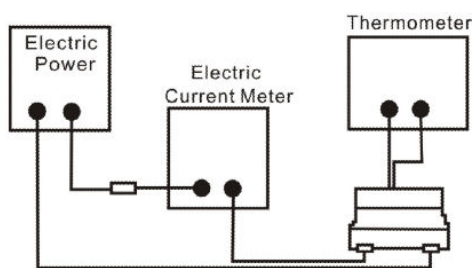

Fig.6.3.4-1

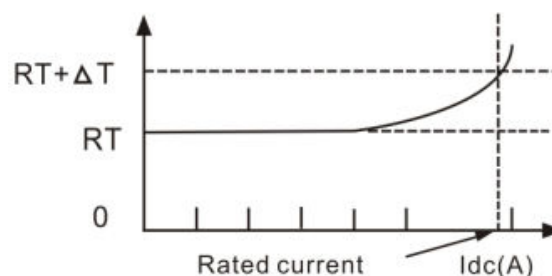
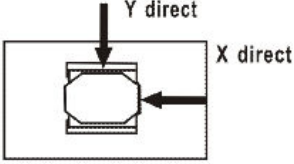
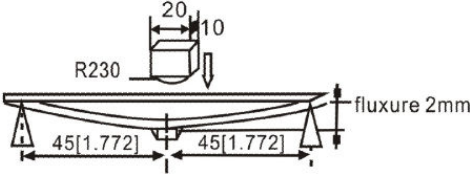
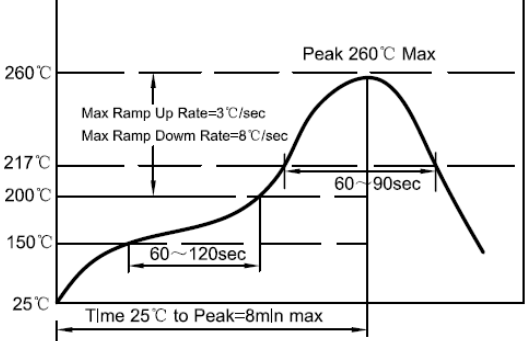
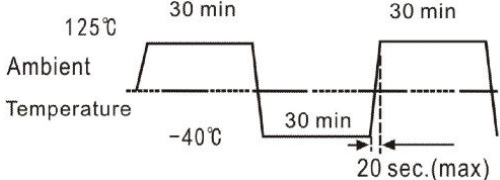

Fig.6.3.4-2

### 6.4 Reliability Test

Items	Requirements	Test Methods and Remarks
6.4.1 Terminal Strength	<p>No removal or split of the termination or other defects shall occur.</p>  <p>Fig.6.4.1-1</p>	<ol style="list-style-type: none"> <li>Solder the inductor to the testing jig (glass epoxy board shown in Fig.6.4.1-1) using eutectic solder. Then apply force in the direction of the arrow.</li> <li>17.7N force.</li> <li>Keep time: 5s</li> </ol>
6.4.2 Resistance to Flexure	<p>No visible mechanical damage.</p>  <p>Fig.6.4.2-1.</p>	<ol style="list-style-type: none"> <li>Solder the chip to the test jig (glass epoxy board) using eutectic solder. Then apply a force in the direction shown as Fig.6.4.2-1.</li> <li>Flexure: 2mm</li> <li>Pressurizing Speed: 0.5mm/sec</li> <li>Keep time: 30±1s</li> <li>Test board size: 100X40X1.0</li> </ol>
6.4.3 Vibration	<ol style="list-style-type: none"> <li>No visible mechanical damage.</li> <li>Inductance change: Within ±10%</li> </ol>	<ol style="list-style-type: none"> <li>Solder the chip to the testing jig (glass epoxy board shown as the following figure) using eutectic solder.</li> <li>The chip shall be subjected to a simple harmonic motion having total amplitude of 1.5mm, the frequency being varied uniformly between the approximate limits of 10 and 55 Hz.</li> <li>The frequency range from 10 to 55 Hz and return to 10Hz shall be traversed in approximately 1 minute. This motion shall be applied for a period of 2 hours in each 3 mutually perpendicular directions (total of 6 hours).</li> </ol>
6.4.4 Temperature coefficient	Inductance change: Within ±20%	<ol style="list-style-type: none"> <li>Temperature: -40°C~+125°C</li> <li>With a reference value of +20°C, change rate shall be calculated</li> </ol>
6.4.5 Solderability	90% or more of electrode area shall be Coated by new solder.	<ol style="list-style-type: none"> <li>The test samples shall be dipped in flux, and then immersed in molten solder.</li> <li>Solder temperature: 245±5°C</li> <li>Duration: 5±1 sec.</li> <li>Solder: Sn/3.0Ag/0.5Cu</li> <li>Flux: 25% resin and 75% ethanol in weight</li> <li>Immersion depth: all sides of mounting terminal shall be immersed</li> </ol>

Items	Requirements	Test Methods and Remarks
6.4.6 Resistance to Soldering Heat	①No visible mechanical damage. ②Inductance change: Within $\pm 10\%$	①Re-flowing Profile: Please refer to Fig. 6.4.6-1 ②Test board thickness: 1.0mm ③Test board material: glass epoxy resin ④The chip shall be stabilized at normal condition for 1~2hours before measuring  Fig. 6.4.6-1
6.4.7 Thermal Shock	① No visible mechanical damage. ②Inductance change: Within $\pm 10\%$ 	①Temperature and time: $-40\pm 3^{\circ}\text{C}$ for $30\pm 3\text{min}$ → $125^{\circ}\text{C}$ for $30\pm 3\text{min}$ ②Transforming interval: Max. 20 sec ③Tested cycle: 100 cycles ④The chip shall be stabilized at normal condition for 1~2 hours before measuring
6.4.8 Resistance to Low Temperature	①No mechanical damage. ②Inductance change: Within $\pm 10\%$	①Temperature: $-40\pm 3^{\circ}\text{C}$ ②Duration: $1000\pm 24$ hours ③The chip shall be stabilized at normal condition for 1~2 hours before measuring
6.4.9 Resistance to High Temperature	①No mechanical damage. ②Inductance change: Within $\pm 10\%$	①Temperature: $125\pm 2^{\circ}\text{C}$ ②Duration: $1000\pm 24$ hours ③The chip shall be stabilized at normal condition for 1~2 hours before measuring.
6.4.10 Damp Heat	①No mechanical damage. ②Inductance change: Within $\pm 10\%$	①Temperature: $85\pm 2^{\circ}\text{C}$ ②Humidity: 80% to 85%RH ③Duration: $1000\pm 24$ hours ④The chip shall be stabilized at normal condition for 1~2 hours before measuring
6.4.11 Loading Under Damp Heat	①No mechanical damage. ②Inductance change: Within $\pm 10\%$	①Temperature: $85\pm 2^{\circ}\text{C}$ ②Humidity: 80% to 85% RH ③Applied current: I rms ④Duration: $1000\pm 24$ hours ⑤The chip shall be stabilized at normal condition for 1~2 hours before measuring
6.4.12 Loading at High Temperature	①No mechanical damage. ②Inductance change: Within $\pm 10\%$	①Temperature: $85\pm 2^{\circ}\text{C}$ ②Applied current: I rms ③Duration: $1000\pm 24$ hours ④The chip shall be stabilized at normal condition for 1~2 hours before measuring

### 7. Packaging, Storage

#### 7.1 Tape and Reel Packaging Dimensions

7.1 .1 Taping Dimensions (Unit: mm)

Please refer to Fig. 7.1.1-1

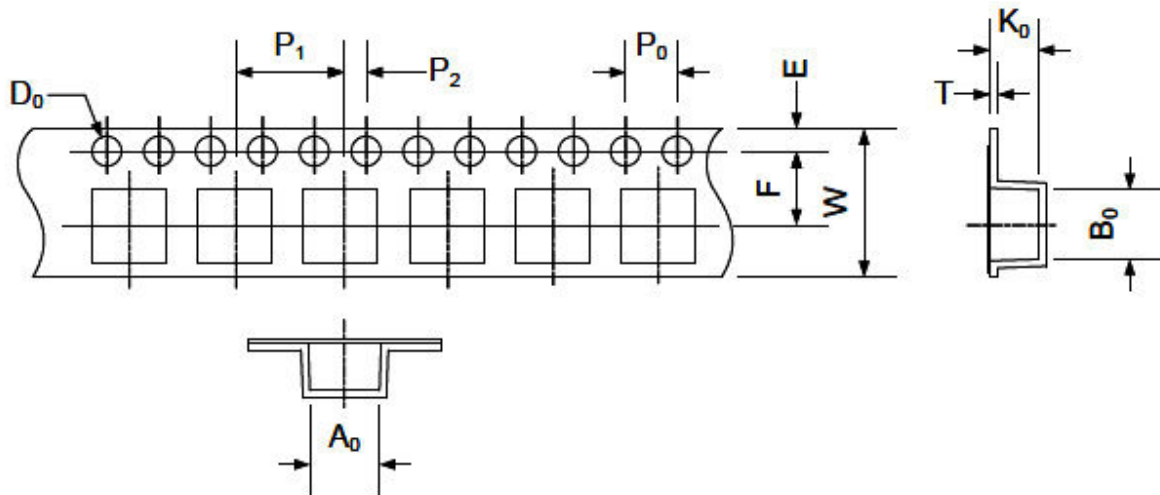

Fig. 7.1.1-1

TYPE	A0	B0	W	E	F	P0	P1	P2	D0	T	K0
ABG10A50	10.5±0.1	10.4±0.1	24.0±0.1	1.75±0.1	11.5±0.1	4.0±0.1	16.0±0.1	2.0±0.1	1.5±0.1	0.5±0.05	5.5±0.1

7.1.2 Direction of rolling

Please refer to Fig. 7.1.2-1.

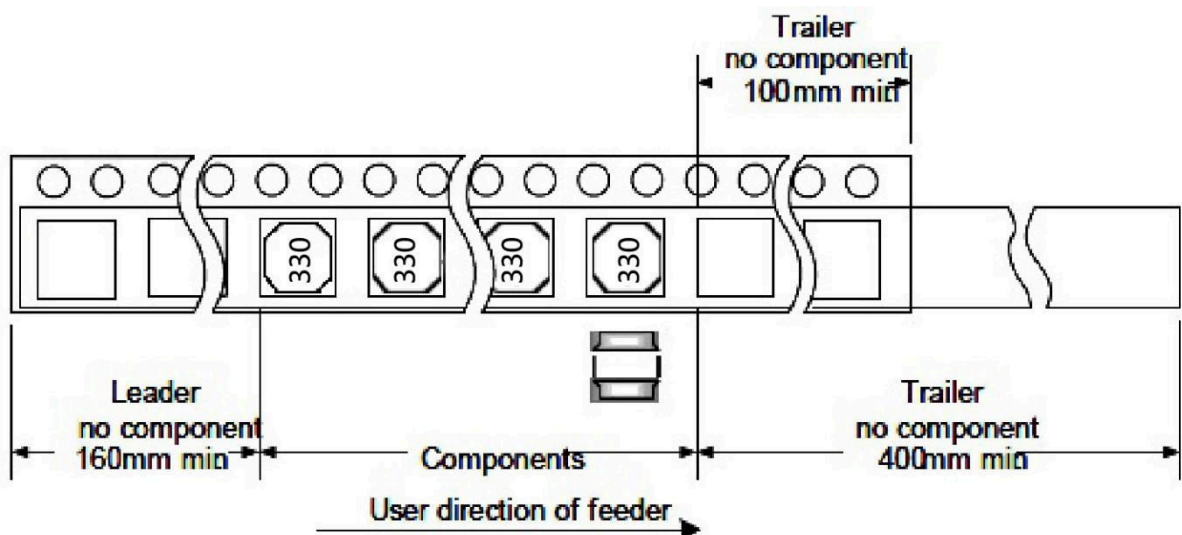

Fig. 7.1.2-1.

### 7.1.3 Reel Dimensions (Unit: mm)

Please refer to Fig. 7.1.3-1.

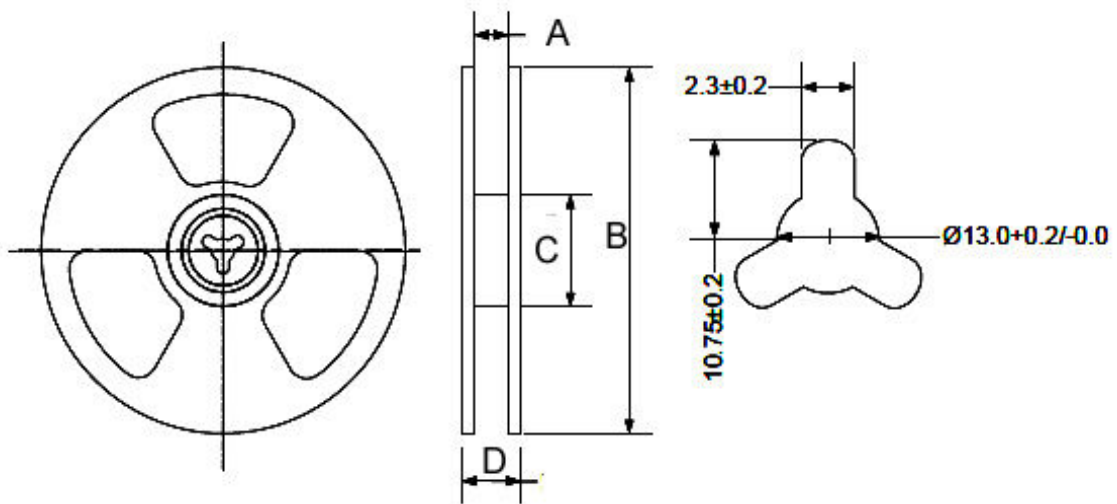

Fig. 7.1.3-1.

TYPE	A	B	C	D
ABG10A50	24.5±2.0	330.0±2.0	100.0±2.0	28.5±2.0

## 7.2 Packaging

7.2.1 The inner box specification: 350\*340\*40MM

Packing quantity: 700PCS/ box

Bubble bag : 37\*45CM

Job description: putting the air bubble bag products placed inside the box, sealed with scotch tape

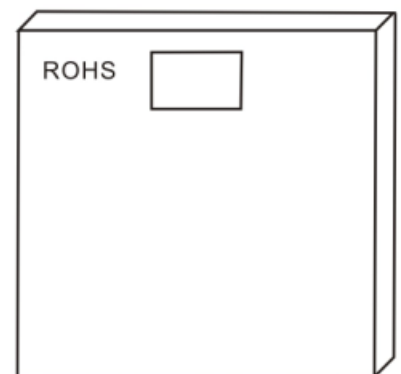

7.2.2 the outside box specification: 370\*360\*255MM

Packing quantity: 2100PCS/ box

Job description: will be outside the box bottom sealed, inner box into the box.

- with transparent tape sealed box at the top
- the specified location with a box labels in the outer box.
- if the mantissa box under a FCL with inner box or filling full

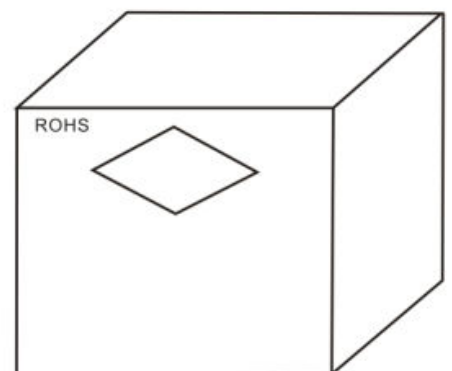

### 7.3 Storage

- To maintain the solderability of terminal electrodes and to keep the packing material in good condition, temperature and humidity in the storage area should be controlled.
- Recommended conditions:  $-10^{\circ}\text{C}\sim 40^{\circ}\text{C}$ , 70%RH (Max.)
- The ambient temperature must be kept below  $30^{\circ}\text{C}$ . Even under ideal storage conditions, solderability of products electrodes may decrease as time passes. For this reason, product should be used with one year from the time of delivery.
- In case of storage over 6 months, solderability shall be checked before actual usage.

## 8. Recommended Soldering Technologies

### 8.1 Re-flowing Profile:

- △ 1~2 °C/sec. Ramp
- △ Pre-heating:  $150\sim 190^{\circ}\text{C}/90\pm 30\text{sec}$ .
- △ Time above  $240^{\circ}\text{C}$ : 20~40sec
- △ Peak temperature:  $255^{\circ}\text{C}$  Max./5sec;
- △ Solder paste: Sn/3.0Ag/0.5Cu
- △ Max.2 times for Re-flowing

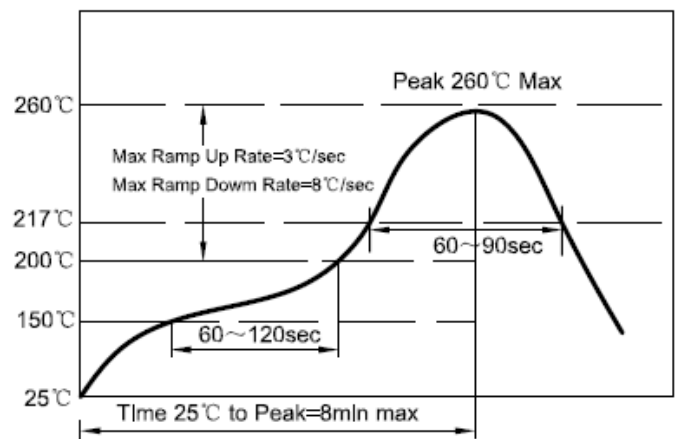

### 8.2 Iron Soldering Profile:

- △ Iron soldering power: Max.30W
- △ Pre-heating:  $150^{\circ}\text{C}/60\text{sec}$ .
- △ Soldering Tip temperature:  $350^{\circ}\text{C}$  Max.
- △ Soldering time: 3sec Max.
- △ Solder paste: Sn/3.0Ag/0.5Cu
- △ Max.1 times for iron soldering

[Note: Take care not to apply the tip of the soldering iron to the]

