

PRODUCT SPECIFICATION

新弘智

SPEC. NO: T-0619-028X

DATE: Aug. 7, 2018

CUSTOMER' S PRODUCT NAME:

EMTEK PRODUCT NAME:

HSC1206-Series

THIS SPECIFICATION IS:

- FULLY ACCEPTED
- DENIED
- ACCEPTED UNDER THE FOLLOWING CONDITIONS



SIGNATURE: _____

DATE: _____

NAME(PRINT): _____

TITLE: _____

 **EMTEK CO., LTD.**

本文件內容全部或部份,未經兆欣科技股份有限公司同意不得以任何形式複製或其他用途
All rights reserved.This document or parts thereof,may not be reproduced by any means or used in any manner without written permission of EMTEK CO.,LTD.

FACTORY:

39, Chingao Rd., (305)Hsinpu,
Hsinchu Hsien, Taiwan, R. O. C

TEL: 03-5894-433

FAX: 03-5894-523

PRODUCT SPECIFICATION

SPEC. NO.
T-0619-028X



1. Scope

This specification applies Ceramic Chip Inductance HSC1206-Series to be delivered to user.

2. Product Identification

HSC 1206 - R62 □ - T
(1) (2) (3) (4) (5)

- (1) Dimension
- (2) Type
- (3) Inductance
R62 : 620 nH
- (4) Tolerance
G=±2% , J=±5% , K=±10%
- (5) Taping Type

3. Shapes and Dimensions

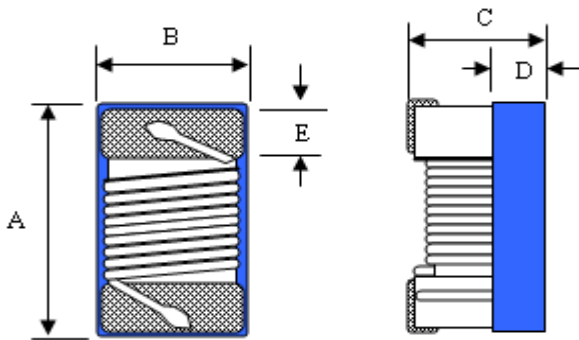

- A max. : 3.56 mm
- B max. : 2.16 mm
- C max. : 1.52 mm
- D ref. : 0.51 mm
- E : 0.51 mm

Equivalent circuit

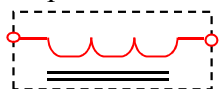

No Polarity

Drawn by	Checked by	Approved by
Cindy Apr. 18. 2017	Zheny Apr. 18. 2017	Su Apr. 18. 2017

PRODUCT SPECIFICATION

SPEC. NO.

T-0619-028X

**4. Electrical Characteristics**

Customer Part Number	Our Product Part Number	Inductance (nH)/MHz	Inductance Tolerance	Q /MHz Min.	SRF (MHz) Min.	Rdc (Ω) Max.	Irms (mA) Max.	Color Coding		
								1st	2nd	3rd
	HSC1206-6N8□-T	6.8/100	J,K	30/300	5500	0.07	1000	Blue	Gray	Black
	HSC1206-8N2□-T	8.2/100	J,K	15/300	3200	0.18	1000	Black	Gray	Black
	HSC1206-10N□-T	10/100	J,K	40/300	4000	0.08	1000	Brown	Black	Black
	HSC1206-12N□-T	12/100	J,K	40/300	3200	0.08	1000	Brown	Red	Black
	HSC1206-15N□-T	15/100	J,K	40/300	3200	0.10	1000	Brown	Green	Black
	HSC1206-22N□-T	22/100	J,K	50/300	2200	0.10	1000	Red	Red	Black
	HSC1206-24N□-T	24/100	J,K	50/300	2000	0.10	1000	Red	Yellow	Black
	HSC1206-27N□-T	27/100	G,J,K	50/300	1800	0.11	1000	Red	Violet	Black
	HSC1206-33N□-T	33/100	J,K	55/300	1800	0.14	1000	Orange	Orange	Black
	HSC1206-39N□-T	39/100	J,K	55/300	1800	0.12	1000	Orange	White	Black
	HSC1206-47N□-T	47/100	G,J,K	55/300	1500	0.19	1000	Yellow	Violet	Black
	HSC1206-56N□-T	56/100	J,K	55/300	1450	0.22	1000	Green	Blue	Black
	HSC1206-62N□-T	62/100	J,K	55/300	1200	0.20	1000	Blue	Red	Black
	HSC1206-68N□-T	68/100	J,K	55/300	1200	0.27	900	Blue	Gray	Black
	HSC1206-82N□-T	82/100	J,K	55/300	1150	0.26	860	Gray	Red	Black
	HSC1206-91N□-T	91/100	J,K	55/300	1100	0.24	900	White	Brown	Black
	HSC1206-R10□-T	100/100	J,K	55/300	1100	0.26	850	Brown	Black	Brown
	HSC1206-R12□-T	120/100	J,K	60/300	1100	0.32	800	Brown	Red	Brown
	HSC1206-R15□-T	150/100	J,K	60/300	950	0.36	750	Brown	Green	Brown
	HSC1206-R18□-T	180/50	G,J,K	60/300	900	0.43	700	Brown	Gray	Brown
	HSC1206-R22□-T	220/50	J,K	60/300	760	0.50	670	Red	Red	Brown
	HSC1206-R27□-T	270/50	G,J,K	55/300	730	0.56	630	Red	Violet	Brown
	HSC1206-R30□-T	300/50	G,J,K	45/150	700	0.58	600	Orange	Black	Brown

PRODUCT SPECIFICATION

SPEC. NO.

T-0619-028X

**4. Electrical Characteristics**

Customer Part Number	Our Product Part Number	Inductance (nH)/MHz	Inductance Tolerance	Q /MHz Min.	SRF (MHz) Min.	Rdc (Ω) Max.	Irms (mA) Max.	Color Coding		
								1st	2nd	3rd
	HSC1206-R33□-T	330/50	G,J,K	45/150	650	0.62	590	Orange	Orange	Brown
	HSC1206-R36□-T	360/50	J,K	45/150	600	0.65	550	Orange	Blue	Brown
	HSC1206-R39□-T	390/50	G,J,K	45/150	600	0.75	530	Orange	White	Brown
	HSC1206-R43□-T	430/50	J,K	47/150	600	1.25	510	Yellow	Orange	Brown
	HSC1206-R47□-T	470/50	G,J,K	47/150	550	1.30	490	Yellow	Violet	Brown
	HSC1206-R56□-T	560/35	G,J,K	45/150	470	1.45	460	Green	Blue	Brown
	HSC1206-R62□-T	620/35	G,J,K	45/150	465	1.52	455	Blue	Red	Brown
	HSC1206-R68□-T	680/35	G,J,K	45/150	460	1.55	450	Blue	Gray	Brown
	HSC1206-R75□-T	750/35	J,K	45/150	440	2.25	320	Violet	Green	Brown
	HSC1206-R82□-T	820/35	J,K	45/150	420	1.82	400	Gray	Red	Brown
	HSC1206-R91□-T	910/35	J,K	45/150	410	2.75	350	White	Brown	Brown
	HSC1206-1R0□-T	1000/35	J,K	45/150	400	2.80	320	Brown	Black	Red
	HSC1206-1R2□-T	1200/35	J,K	45/150	380	3.20	300	Brown	Red	Red
	HSC1206-1R8□-T	1800/7.96	J,K	25/25.2	200	3.90	300	Brown	Gray	Red

- All specifications are calibrated with Coilcraft 1206CS series
- When ordering, please specify tolerance and packaging codes. Ex: HSC1206-R62G-T
Tolerance :G=±2% , J = ±5% , K=±10%
Packaging : Clear tape and reel { standard } . *
- L , Q , SRF: Agilent E4991A RF Impedance/Material Analyzer+ Agilent 16197A Test Fixtures
(The electrical specification test by the smallest gap position), or equivalent
- Rdc : Chroma 16502 Milliohm meter, or equivalent.
- Irms for a 25°C rise above 25°C ambient.
- Operating temperature range from -40°C to 125°C.
* Parts/Reel: 7" 2,000 Tape Width: 8mm

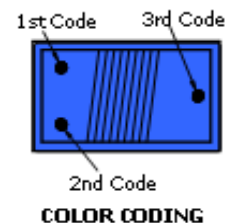

PRODUCT SPECIFICATION

SPEC. NO.

T-0619-028X

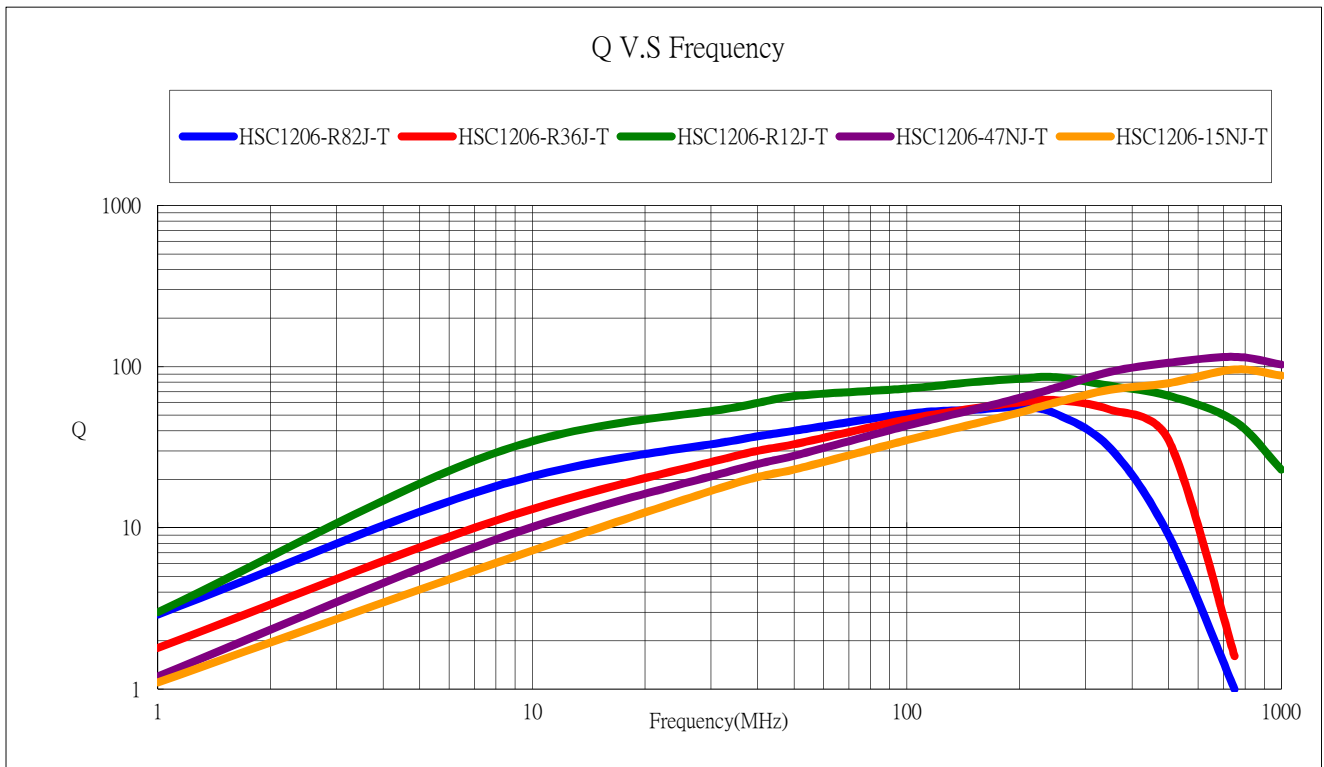
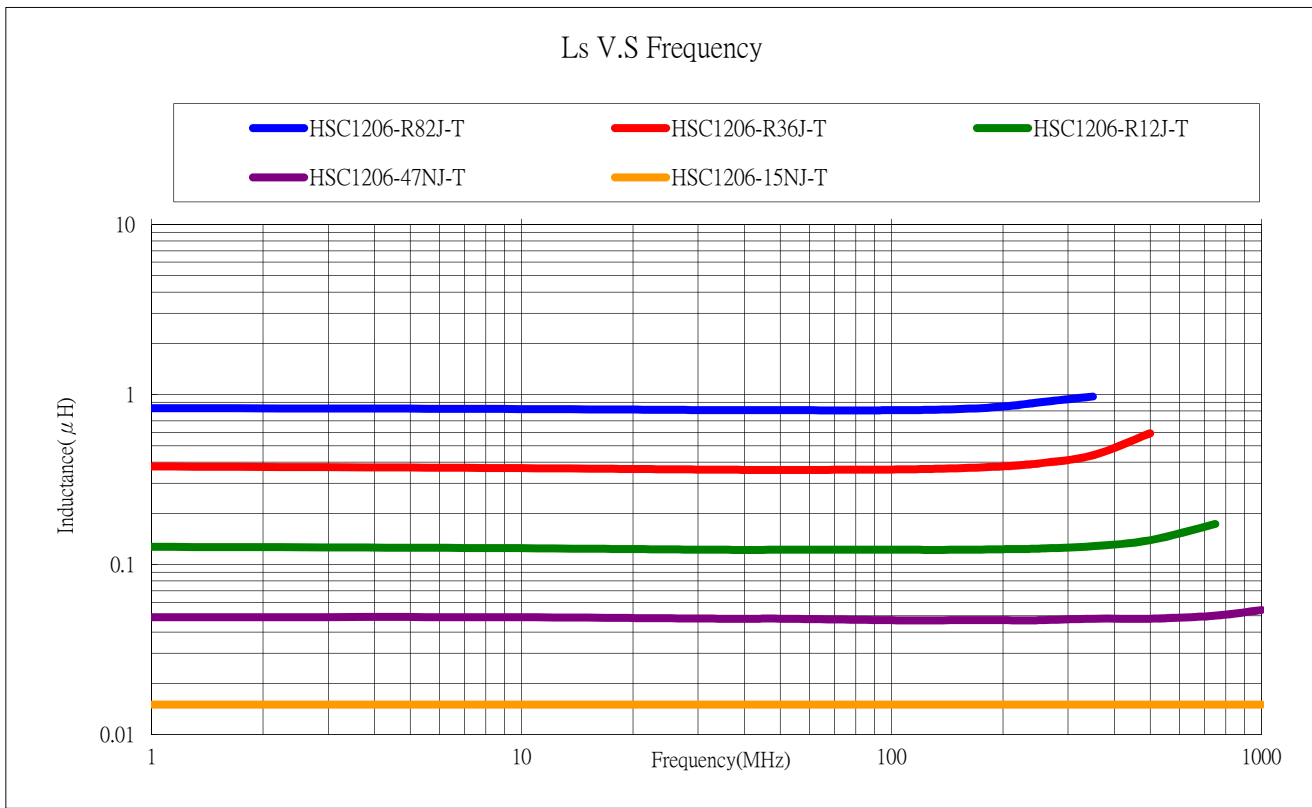

PRODUCT SPECIFICATION

SPEC. NO.

T-0619-028X



5. Material list

Item	Material
Core	Al ₂ O ₃ 96%
Wire	Copper wire
Epoxy	UV Epoxy

PRODUCT SPECIFICATION

SPEC. NO.

T-0619-028X

**6. Reliability Test**

Item	Specifications	Test conditions
Solderability	The metalized area must have 90% minimum solder coverage.	Dip pads in flux and dip in solder pot(96.5 Sn/3.5 Ag solder) at 255°C ±5°C.
Resistance to soldering heat	There must be no case deformation or change in dimensions. Inductance must not change more than the stated tolerance.	Inductors shall be reflowed onto a PC board using 96.5 Sn/3.5 Ag solder paste. Solder process shall be at a maximum temperature of 260°C. For 96.5 Sn/3.5 Ag solder paste:>217°C for 90 seconds
Vibration	There must be no case deformation or change in dimensions. Inductance must not change more than the stated tolerance.	Solder specimen inductor on the test printed circuit board. Apply vibrations in each of the x,y and z directions for 2 hours for a total of 6 hours. Frequency : 10~50 Hz Amplitude : 1.5mm
High temperature resistance	There must be no case deformation or change in dimensions. Inductance must not change more than the stated tolerance.	Inductors shall be subjected to temperature 125±2°C for 50±12 hours. Measure the test items after leaving the inductors at room temperature and humidity for 2 hours.
Static Humidity	Inductors must not have a shorted or openwinding.	Inductors shall be subjected to temperature 85±2°C and 90 to 95%RH. for ten 24-hours. Measure the test items after leaving the inductors at room temperature and humidity for 2 hours.
Component adhesion (push test)	Inductors shall be subjected to 1.8Kg	Inductors shall be reflow soldered (255°C ±5°C for 10 seconds) to a tinned copper substrate. A force gauge shall be applied to the side of the component. The device must withstand the stated force without a failure of the termination.

PRODUCT SPECIFICATION

SPEC. NO.

T-0619-028X

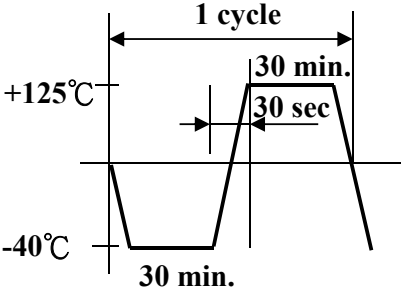

Item	Specifications	Test conditions
Low temperature resistance	There must be no case deformation or change in dimensions. Inductance must not change more than the stated tolerance.	Inductors shall be subjected to temperature $-40\pm 2^{\circ}\text{C}$ for 48 ± 12 hours. Measure the test items after leaving the inductors at room temperature and humidity for 1 to 2 hours.
Resistance to solvent	There must be no case deformation, change in dimensions, or obliteration of marking.	Inductors must withstand 6 minutes of alcohol or water.
Thermal shock	There must be no case deformation or change in dimensions. Inductance must not change more than the stated tolerance.	Inductors shall be subjected to 10 cycles to the the following temperature cycle: <div style="text-align: center;">  <p>The diagram illustrates a temperature cycle. The vertical axis shows temperature with markers at $+125^{\circ}\text{C}$ and -40°C. The horizontal axis represents time. A single cycle consists of: a ramp down to -40°C, a 30 min. dwell at -40°C, a ramp up to $+125^{\circ}\text{C}$, a 30 min. dwell at $+125^{\circ}\text{C}$, and a ramp back to the baseline. The total duration of one cycle is labeled as '1 cycle'.</p> </div> Measure the test items after leaving the inductors at room temperature and humidity for 2 hours.

PRODUCT SPECIFICATION

SPEC. NO.

T-0619-028X



7. Packaging

The packaging must be done not to receive any damage during transporting and storing.

7-1 Tape dimensions

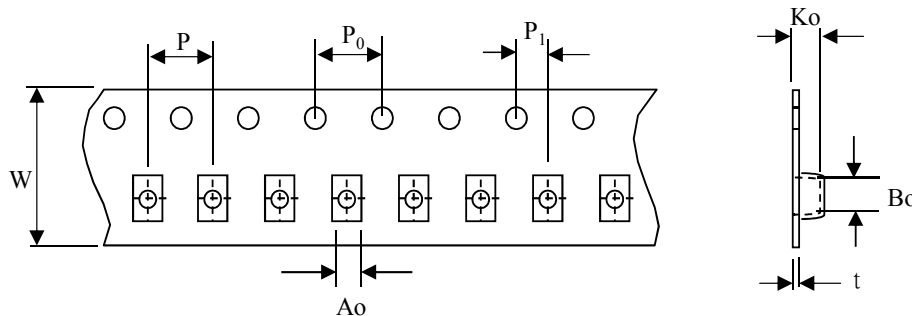

(Dimensions in mm)

Symbol	W	P	P ₀	P ₁	A _o	B _o	K _o	t
Dimension	8	4	4	2	2.14	3.56	1.5	0.22
Tolerance	±0.10	±0.10	±0.10	±0.10	±0.05	±0.05	±0.05	±0.05

7-2 Reel dimensions

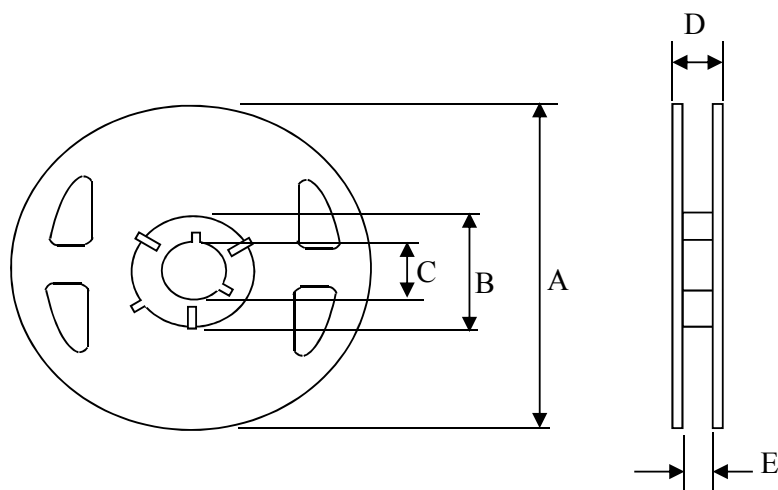

(Dimensions in mm)

Symbol	T
A	180
B	60
C	13
D	14.4
E	8.4

7-3 Tapping figure

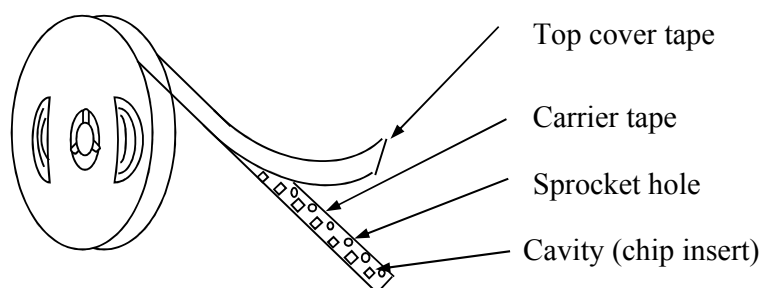

PRODUCT SPECIFICATION

SPEC. NO.

T-0619-028X



7-4 Packaging Form

There shall not continuation more than two vacancies of the product.

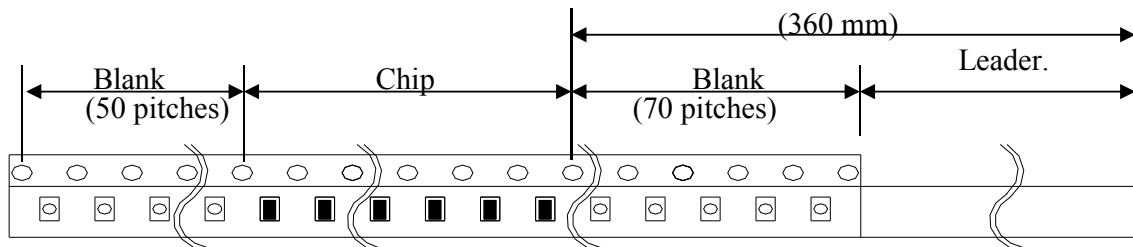

7-5 Cover Tape Peel Strength

The force for tearing off cover tape is 0.1~0.6(N) in the arrow direction at the following conditions:

Temperature : 5 ~ 35°C

Humidity : 45 ~ 85%

Atmospheric pressure : 860 ~ 1060 hpa

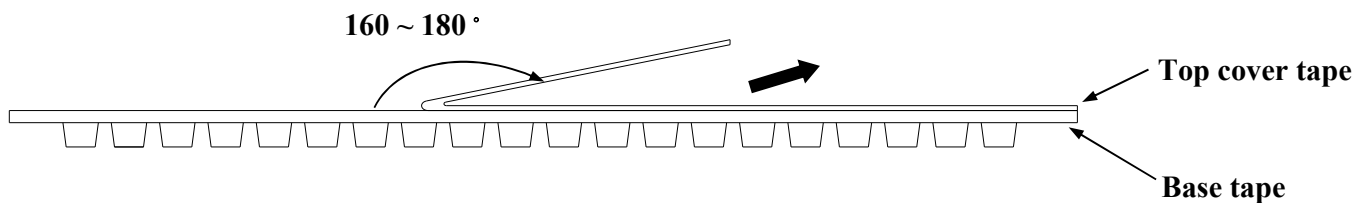

7-6 Packing Quantity

φ180 mm reel type : 2,000 pcs./reel

PRODUCT SPECIFICATION

SPEC. NO.

T-0619-028X



8. Recommended Soldering Conditions (Please use this product by reflow soldering)

8-1 Recommended Footprint

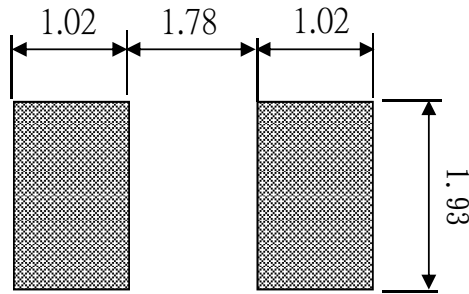

8-2 Recommended Reflow Pattern

Reflow : until two times

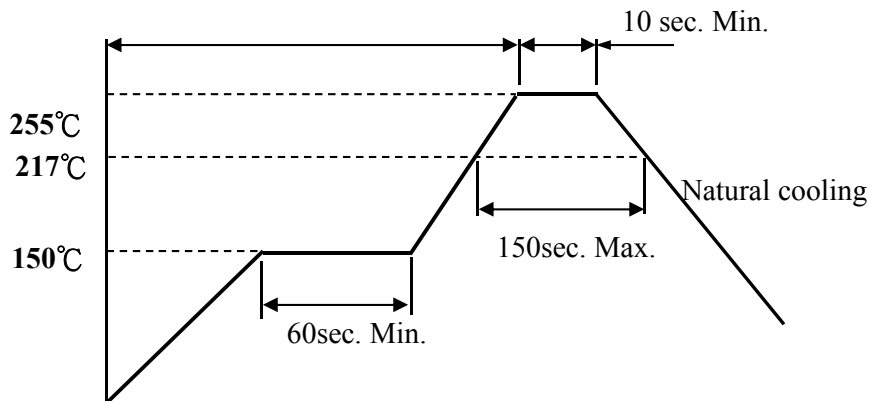

8-3 Iron Soldering

Use a solder iron of less than 30W when soldering, do not allow the soldering iron tip directly touch the Ceramic body outside of terminal electrode.

4 seconds max. at 260°C.

9. Attention in Case of Using

In case of using product, please avoid following matters:

Splashing water or salt water

Dew condenses

Toxic gas (Hydrogen sulfide, Sulfurous acid, Chlorine, Ammonia)

Vibrations or shocks which exceed the specified condition

Please be careful for the stress to this product by board flexure or something after the mounting.

10. Others

10-1 Operating temperature range : Ferrite Series : -25~+85°C

Ceramic Series : -40~+125°C

10-2 Storage condition : Temperature 20°~25°C, Relative Humidity 40%~60%

10-3 Recommended wire wound inductors should be used within 6 months from the time of delivery.