



Applications Note:AN_SY8104

High Efficiency, 500kHz, 4A, 18V Input Synchronous Step Down Regulator

General Description

The SY8104 is a high efficiency 500 kHz synchronous step-down DC-DC converter capable of delivering 4.0A current. The SY8104 operates over a wide input voltage range from 4.5V to 18V and integrates main switch and synchronous switch with very low $R_{DS(ON)}$ to minimize the conduction loss.

Low output voltage ripple and small external inductor and capacitor sizes are achieved with 500 kHz switching frequency. It adopts the instant PWM architecture to achieve fast transient responses for high step down applications

Ordering Information

SY8104 □(□□)□

Temperature Code
Package Code
Optional Spec Code

Ordering Number	Package type	Note
SY8104ADC	TSOT23-6	--

Features

- low $R_{DS(ON)}$ for internal switches (top/bottom): 50mΩ/30mΩ
- 4.5-18V input voltage range
- 4.0A output current capability
- 500 kHz switching frequency
- Instant PWM architecture to achieve fast transient responses.
- Internal softstart limits the inrush current
- Output discharge function
- Cycle-by-cycle peak current limitation
- $\pm 1.5\%$ 0.6V reference
- Pb Free and Halogen Free
- TSOT23-6 package

Applications

- Set Top Box
- Portable TV
- Access Point Router
- DSL Modem
- LCD TV

Typical Applications

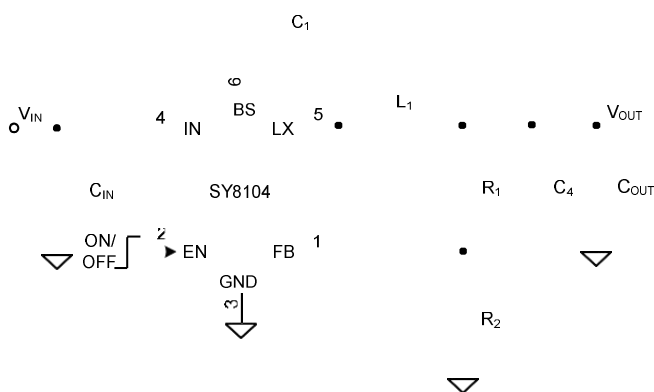

Figure 1. Schematic Diagram

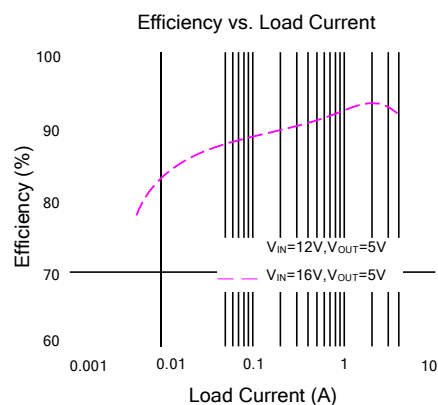

Figure 2. Efficiency vs. Load Current

Pinout (top view)



TSOT23-6

Top Mark: JRxyz, (Device code: JR, x=year code, y=week code, z=lot number code)

Pin Name	Pin Number	Pin Description
FB	1	Output Feedback Pin. Connect this pin to the center point of the output resistor divider (as shown in Figure 1) to program the output voltage: $V_{out}=0.6*(1+R1/R2)$
EN	2	Enable control. Pull high to turn on. Do not float.
GND	3	Ground pin
IN	4	Input pin. Decouple this pin to GND pin with at least 1uF ceramic cap
LX	5	Inductor pin. Connect this pin to the switching node of inductor
BS	6	Boot-Strap Pin. Supply high side gate driver. Decouple this pin to LX pin with 0.1uF ceramic cap.

Block Diagram

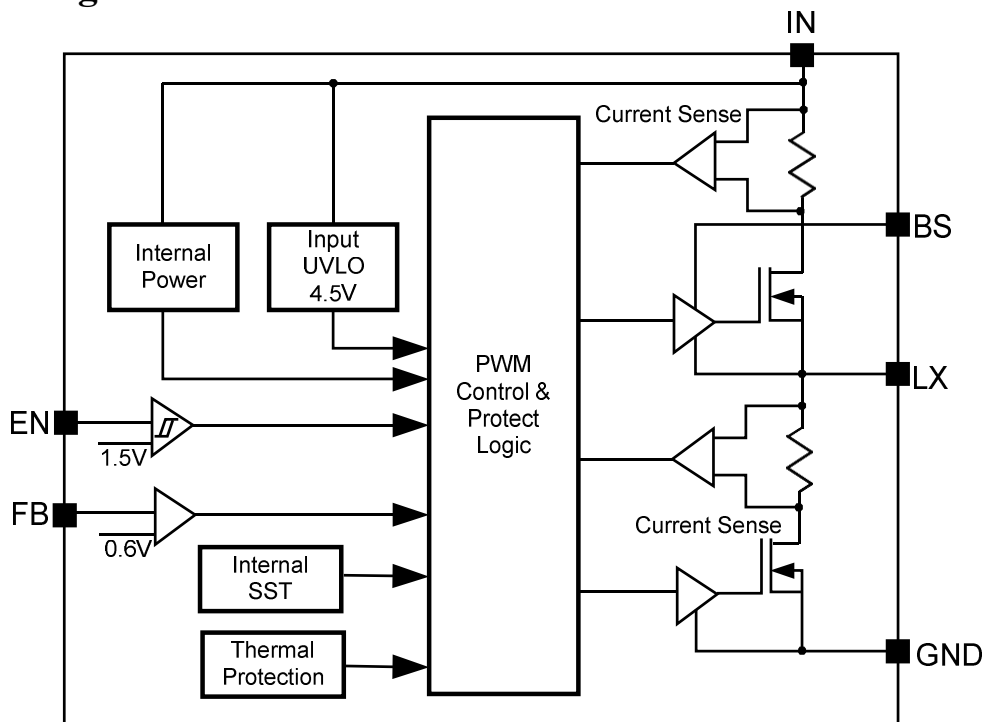



Absolute Maximum Ratings (Note 1)

Supply Input Voltage	V
Enable Voltage	VIN + 0.3V
FB Voltage	V
LX Voltage	-0.3V to 19V
BS-LX Voltage	-0.3V to 4V
Power Dissipation, PD @ TA = 25°C, TSOT23-6	1.75W
Package Thermal Resistance (Note 2)	
θJA	56°C/W
θJC	6.3°C/W
Junction Temperature Range	-150°C
Lead Temperature (Soldering, 10 sec.)	260°C
Storage Temperature Range	-65°C to 150°C
Dynamic LX voltage in 10ns duration	IN+3V to GND-5V

Recommended Operating Conditions (Note 3)

Supply Input Voltage	4.5V to 18V
Junction Temperature Range	40°C to 125°C
Ambient Temperature Range	40°C to 85°C



Electrical Characteristics

($V_{IN} = 12V$, $V_{OUT} = 1.2V$, $L = 2.2\mu H$, $C_{OUT} = 47\mu F$, $T_A = 25^\circ C$, $I_{OUT} = 1A$ unless otherwise specified)

Parameter	Symbol	Test Conditions	Min	Typ	Max	Unit
Input Voltage Range	V_{IN}		4.5		18	V
Quiescent Current	I_Q	$I_{OUT}=0$, $V_{FB}=V_{REF}*105\%$		100		μA
Shutdown Current	I_{SHDN}	EN=0		5	10	μA
Feedback Reference Voltage	V_{REF}		0.591	0.6	0.609	V
FB Input Current	I_{FB}	$V_{FB}=3.3V$	-50		50	nA
Top FET RON	$R_{DS(ON)1}$			50		m Ω
Bottom FET RON	$R_{DS(ON)2}$			30		m Ω
Top FET Peak Current Limit	$I_{LIM, TOP}$				8.5	A
Bottom FET Valley Current Limit	$I_{LIM, BOTTOM}$		4.0			A
EN Rising Threshold	V_{ENH}		1.5			V
EN Falling Threshold	V_{ENL}				0.4	V
Input UVLO Threshold	V_{UVLO}				4.5	V
UVLO Hysteresis	V_{HYS}			0.3		V
Min ON Time				80		ns
Min OFF Time				160		ns
Switching Frequency				500		kHz
Soft-start time	t_{SS}		400	800	1200	μs
Output Discharge Current	I_{DIS}	$V_O=3.3V$		70		mA
Thermal Shutdown Temperature	T_{SD}			150		$^\circ C$
Thermal Shutdown Hysteresis	T_{HYS}			15		$^\circ C$

Note 1: Stresses beyond the “Absolute Maximum Ratings” may cause permanent damage to the device. These are stress ratings only. Functional operation of the device at these or any other conditions beyond those indicated in the operational sections of the specification is not implied. Exposure to absolute maximum rating conditions for extended periods may affect device reliability.

Note 2: θ_{JA} is measured in the natural convection at $T_A = 25^\circ C$ on a two-layer Silergy Evaluation Board..

Note 3: The device is not guaranteed to function outside its operating conditions

Typical Performance Characteristics

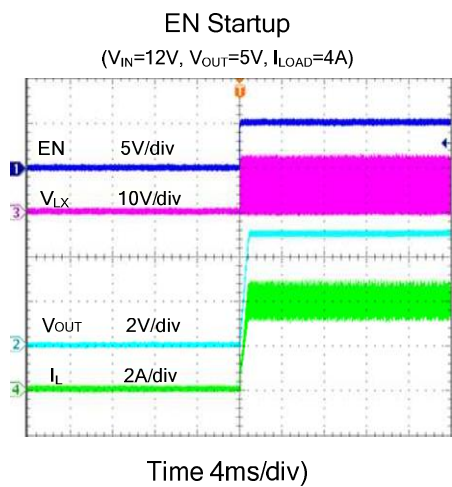
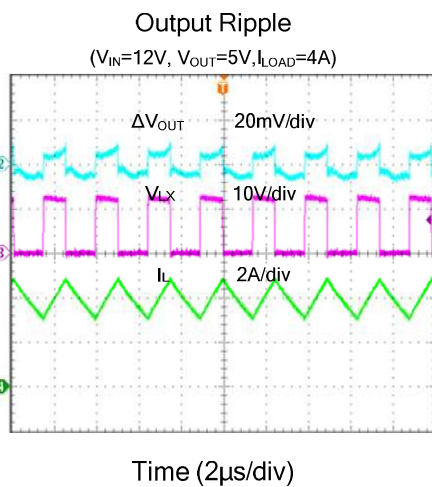
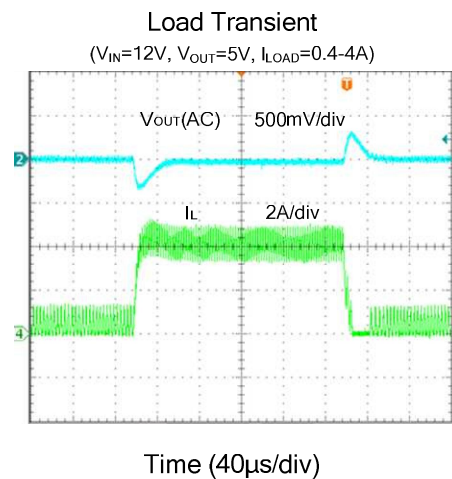
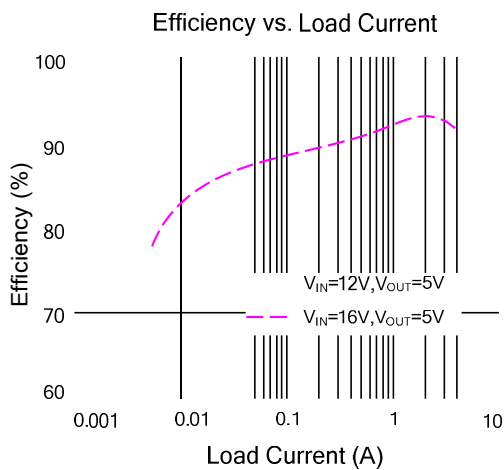
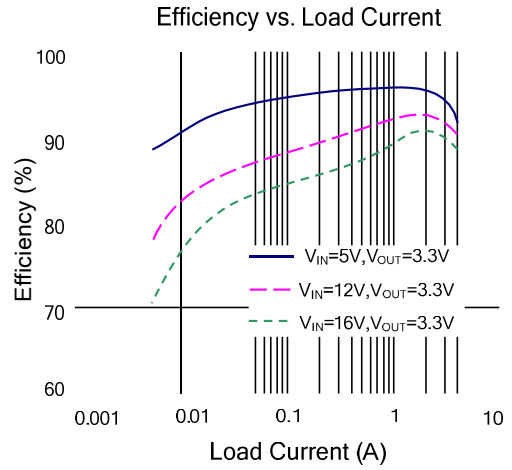
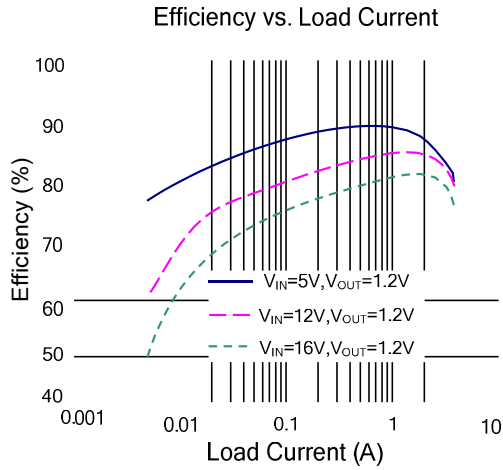

EN Shutdown

($V_{IN}=12V$, $V_{OUT}=5V$, $I_{LOAD}=4A$)

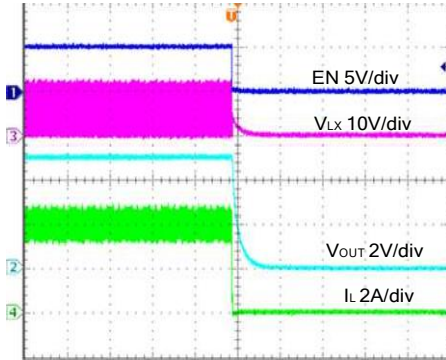

Time (400µs/div)

Short Circuit Protection

($V_{IN}=12V$, $V_{OUT}=5V$, 4A to Short)

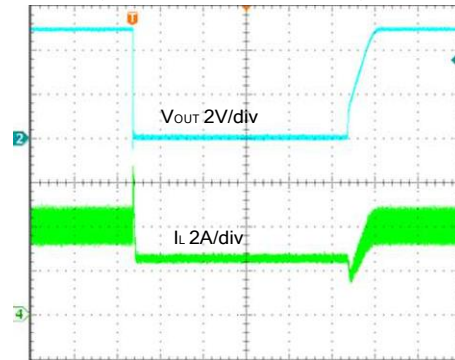

Time (1ms/div)

Short Circuit Protection

($V_{IN}=12V$, $V_{OUT}=5V$, Open to Short)

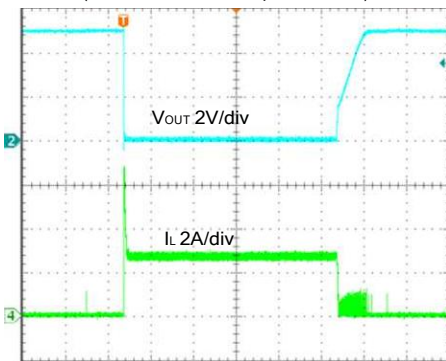

Time (1ms/div)



Operation

SY8104 is a synchronous buck regulator IC that integrates the PWM control, top and bottom switches on the same die to minimize the switching transition loss and conduction loss. With ultra low $R_{DS(ON)}$ power switches and proprietary PWM control, this regulator IC can achieve the high efficiency and fast transient response. The high switching frequency allows using of small profile inductor and capacitor and the highest switch frequency simultaneously to minimize the external inductor and capacitor size, and thus achieving the minimum solution footprint.

Applications Information

Because of the high integration in the SY8104 IC, the application circuit based on this regulator IC is rather simple. Only input capacitor C_{IN} , output capacitor C_{OUT} , output inductor L and feedback resistors (R_1 and R_2) need to be selected for the targeted applications specifications.

Feedback resistor dividers R_1 and R_2 :

Choose R_1 and R_2 to program the proper output voltage. To minimize the power consumption under light loads, it is desirable to choose large resistance values for both R_1 and R_2 . A value of between 10k Ω and 1M Ω is highly recommended for both resistors. If V_{out} is 3.3V, $R_1=100k$ is chosen, then using following equation, R_2 can be calculated to be 22.1k:

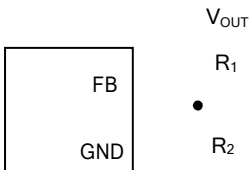
$$R_2 = \frac{0.6V}{V_{OUT} - 0.6V} R_1$$

Input capacitor C_{IN} :

The ripple current through input capacitor is calculated as:

$$I_{CIN_RMS} = I_{OUT} \cdot \sqrt{D(1-D)}$$

To minimize the potential noise problem, place a typical X5R or better grade ceramic capacitor really close to the IN and GND pins. Care should be taken to minimize the loop area formed by C_{IN} , and IN/GND pins. For most applications, a 10uF ceramic capacitor in parallel with 100nF 0603 size ceramic capacitor are

recommended. And place the 100nF/0603 capacitor close to IC to attenuate high frequency noise.

Output capacitor C_{OUT} :

The output capacitor is selected to handle the output ripple noise requirements. Both steady state ripple and transient requirements must be taken into consideration when selecting this capacitor. For the best performance, it is recommended to use X5R or better grade ceramic capacitor greater than 47uF capacitance.

Output inductor L:

There are several considerations in choosing this inductor.

- 1) Choose the inductance to provide the desired ripple current. It is suggested to choose the ripple current to be about 40% of the maximum output current. The inductance is calculated as:

$$L = \frac{V_{OUT}(1 - V_{OUT}/V_{IN,MAX})}{F_{SW} \times I_{OUT,MAX} \times 40\%}$$

where F_{sw} is the switching frequency and $I_{OUT,MAX}$ is the maximum load current.

The SY8104 regulator IC is quite tolerant of different ripple current amplitude. Consequently, the final choice of inductance can be slightly off the calculation value without significantly impacting the performance.

- 2) The saturation current rating of the inductor must be selected to be greater than the peak inductor current under full load conditions.

$$I_{SAT, MIN} > I_{OUT, MAX} + \frac{V_{OUT}(1 - V_{OUT}/V_{IN,MAX})}{2 \cdot F_{SW} \cdot L}$$

- 3) The DCR of the inductor and the core loss at the switching frequency must be low enough to achieve the desired efficiency requirement. It is desirable to choose an inductor with $DCR < 20m\Omega$ to achieve a good overall efficiency.

Soft-start

The SY8104 has a built-in soft-start to control the rise rate of the output voltage and limit the input current surge during IC start-up. The typical soft-start time is 800us.

Enable Operation

Pulling the EN pin low (<0.4V) will shut down the device. During shutdown mode, the SY8104 shutdown current drops to lower than 5uA. Driving the EN pin high (>1.5V) will turn on the IC again.

External Bootstrap Cap

This capacitor provides the gate driver voltage for internal high side MOSEFET. A 100nF low ESR ceramic capacitor connected between BS pin and LX pin is recommended.

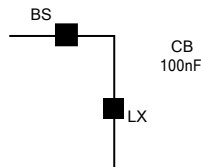

Load Transient Considerations:

The SY8104 regulator IC integrates the compensation components to achieve good stability and fast transient responses. In some applications, adding a 22pF ceramic cap in parallel with R1 may further speed up the load transient responses and is thus recommended for applications with large load transient step requirements.

Layout Design:

The layout design of SY8104 regulator is relatively simple. For the best efficiency and minimum noise problem, we should place the following components close to the IC: C_{IN}, L, R₁ and R₂.

1) It is desirable to maximize the PCB copper area connecting to GND pin to achieve the best thermal and noise performance. If the board space allowed, a ground plane is highly desirable.

2) C_{IN} must be close to Pins IN and GND. The loop area formed by C_{IN} and GND must be minimized.

3) The PCB copper area associated with LX pin must be minimized to avoid the potential noise problem.

4) The components R₁ and R₂, and the trace connecting to the FB pin must NOT be adjacent to the LX net on the PCB layout to avoid the noise problem.

5) If the system chip interfacing with the EN pin has a high impedance state at shutdown mode and the IN pin is connected directly to a power source such as a Li-Ion battery, it is desirable to add a pull down 1Mohm resistor between the EN and GND pins to prevent the noise from falsely turning on the regulator at shutdown mode.

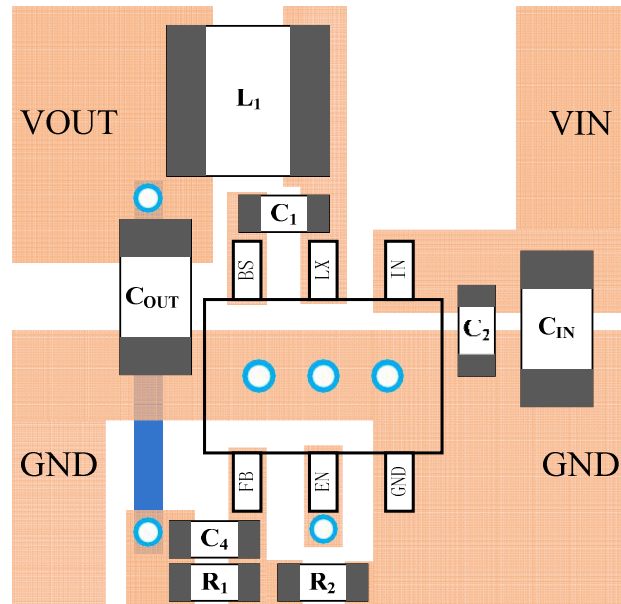

TSOT23-6 Package outline & PCB layout

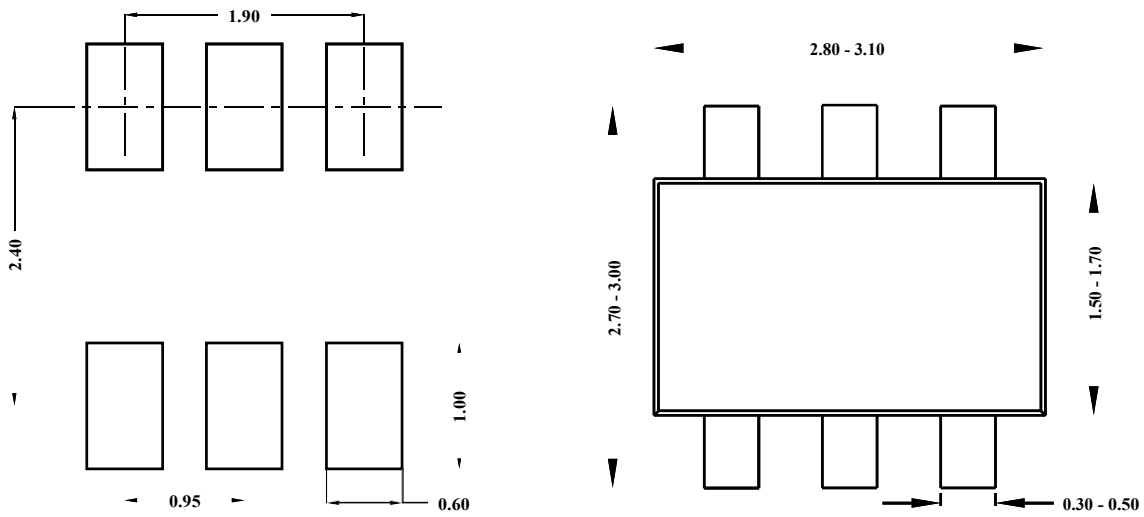

Recommended Pad Layout

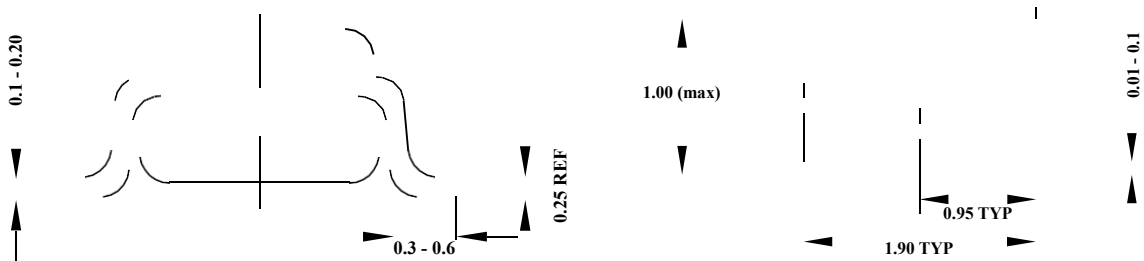

Notes: All dimension in millimeter
All dimension don't include mold flash & metal burr

Taping & Reel Specification

1. Taping orientation

TSOT23-6

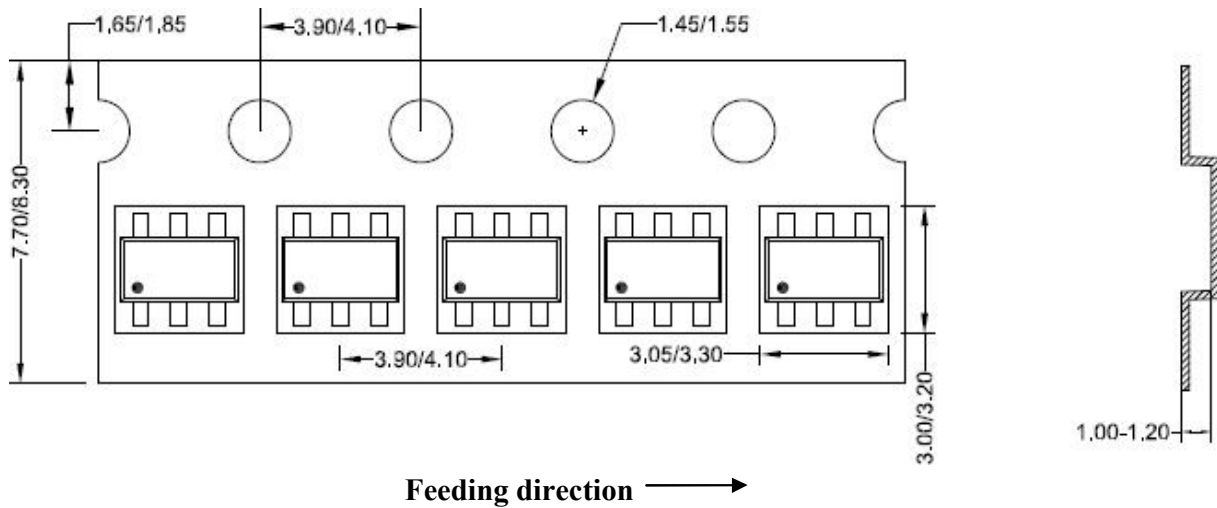

2. Carrier Tape & Reel specification for packages

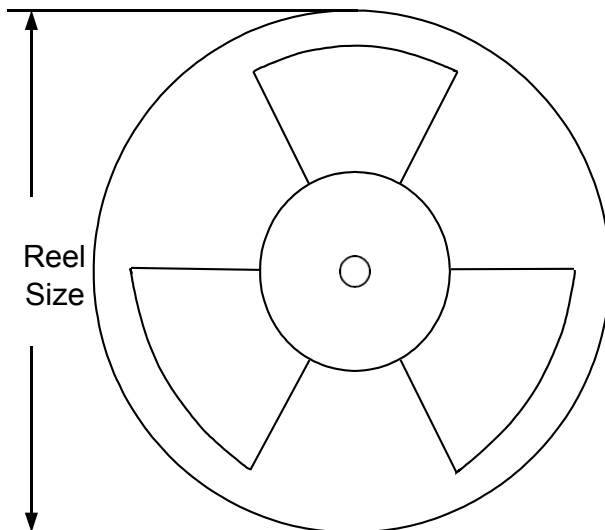

Package types	Tape width (mm)	Pocket pitch(mm)	Reel size (Inch)	Trailer length(mm)	Leader length (mm)	Qty per reel
TSOT23-6	8	4	7"	400	160	3000

3. Others: NA