



APPROVAL SHEET

PRODUCT NAME	SMD CRYSTAL UNIT		
USER NAME			
USER PART NO.			
Provider	PARTRON		
PARTRON MODEL	CXC8X160000GJVRN00		
CUSTOMER	Issued by	Checked by	Approved by
PARTRON	Issued by	Checked by	Approved by
	<i>J.S.B. Jung</i>	<i>[Signature]</i>	<i>[Signature]</i>
In Charge	J.S.B	M.N.S	K.J.M
Division	R&D	QC	R&D
MSL	LEAD FREE	Halogen-Free	
MSL LEVEL 1			

	Case
Fab	China/Yantai/Partron
Assembly	China/Yantai/Partron
Final Test & Packing	China/Yantai/Partron

※ Please return one copy with approval to PARTRON

2016. 02. 24

22-6, Seokwoo-dong, Hwaseong-si, Gyeonggi-do, Korea 445-170

TEL : 82-31-201-7750

Contents

1. Revision History	- - - 3
2. Electrical characteristics	- - - 4
3. Mechanical characteristics	- - - 6
4. A Primary test result	- - - 7
5. Reliability test	- - - 8
6. Soldering Condition	- - - 9
7. Construction	- - - 10
8. Notices	- - - 11
9. Packing	- - - 12

2. Electrical Characteristics

No.	Item	Symbol	Content
2.1	Frequency	fo	16.0000 MHz
2.2	Frequency Tolerance 	$\Delta f/fo$	± 10 ppm (@+25°C $\pm 2^\circ\text{C}$)
2.3	Temperature range	Storage	T _{STG} -40 to 85°C
		Operating	T _{OPR} -20 to 85°C
2.4	Frequency stability	$\Delta f/fo$	± 10 ppm (-20 to +85°C, Ref. @+25°C $\pm 2^\circ\text{C}$)
2.5	Drive level	DL	100 μW max.
2.6	Equivalent series resistance	R1	150 Ω max.
2.7	Oscillation mode	O/T	Fundamental
2.8	Shunt capacitance	C0	3 pF max.
2.9	Motional capacitance	C1	10 fF max.
2.10	Load capacitance	C _L	9.0 pF
2.11	Aging	fa	± 3 ppm/3year max. (@+25°C $\pm 2^\circ\text{C}$)
2.12	Insulation resistance	IR	500 M Ω min @ 100VDC
[REMARK]			

2.1 Crystal Equivalent Circuit and Application Circuit

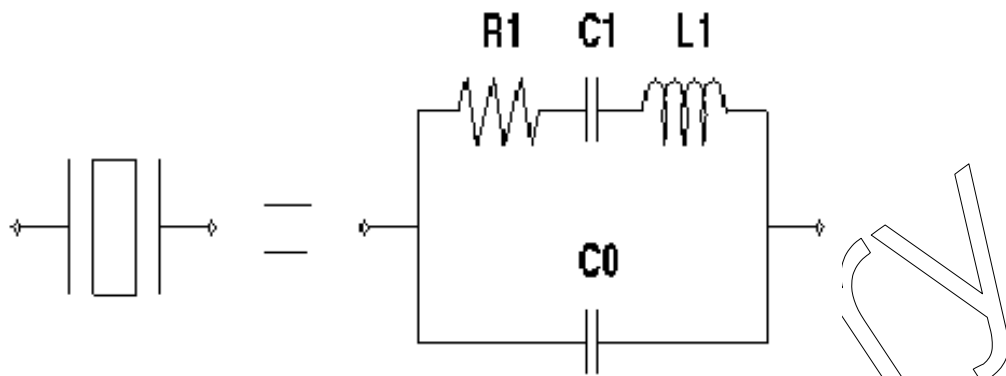

[Crystal and equivalent circuit]

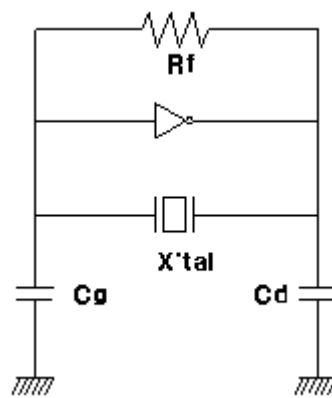

[Application circuit for oscillation]

3. Mechanical characteristics

3.1 Outline Dimensions and Pin connections

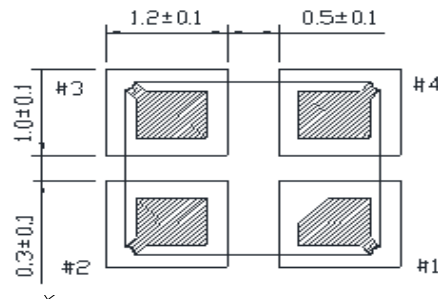
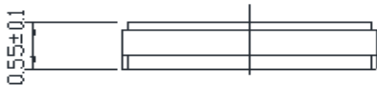
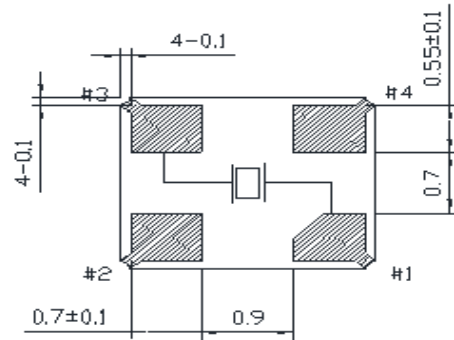
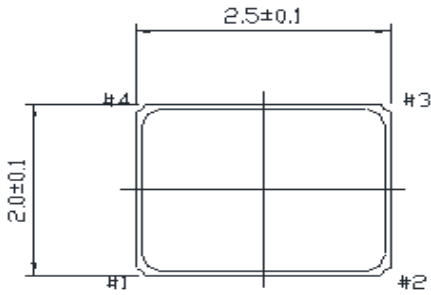

Pin connections	
#1	HOT
#2	GND
#3	HOT
#4	GND

[Recommended solder pad layout]

3.2 Marking and LOT No

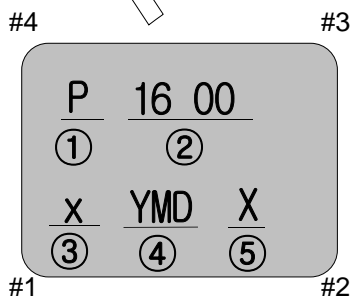

※Laser Marking

ITEM	MARKING	REMARK
①	P	
②	16 00	Frequency: 16.0000MHz
③	X	CRYSTAL CL (1 digit)
④	YMD	Y : the last 1 digit of year M : 1 digit of month (Jan to Sept; 1 to 9, Oct; A,Nov B, Dec;C) D : 1 digit of day 1 to 9, A to V (A=10, V=31) EX) 769 = 2007.06.09, 8AS = 2008.10.28
⑤	X	Internal Code

* Note 1

1 Digit	S	T	R	N	B	P	C	Q	D	E	F	G	H
Crystal CL	6pF	7pF	8pF	9pF	10pF	11pF	12pF	13pF	14pF	15pF	16pF	18pF	20pF

4. A Primary test result

Electrical Characteristics Testing Data

No.	Item	Result	FL (ppm)	C0 (pF)	RR (Ω)	C1 (fF)	L (mH)	TS (ppm/pF)	Remark
Spec	High		10.0	3.0	150.0	10.0	-	-	
	Low		-10.0	-	-	-	-	-	
	Max	Pass	4.9	0.8	87.2	1.7	66.7	8.8	
	Min	Pass	3.2	0.8	58.7	1.5	58.8	7.7	
	Average	Pass	4.1	0.8	74.7	1.6	62.2	8.4	
	Stdev	Pass	0.6	0.0	9.7	0.1	2.3	0.3	
1		Pass	4.6	0.8	76.7	1.6	62.6	8.3	
2		Pass	3.4	0.8	87.2	1.6	62.4	8.3	
3		Pass	4.5	0.8	81.6	1.6	62.8	8.3	
4		Pass	3.7	0.8	63.9	1.7	58.8	8.8	
5		Pass	4.9	0.8	64.1	1.5	66.7	7.7	
6		Pass	4.3	0.8	85.3	1.5	64.6	8.0	
7		Pass	3.6	0.8	58.7	1.6	61.5	8.4	
8		Pass	3.2	0.8	80.5	1.6	61.1	8.5	
9		Pass	4.6	0.8	72.6	1.7	59.8	8.7	
10		Pass	4.5	0.8	76.1	1.6	61.6	8.4	

PRELIMINARY

5. Reliability test

5.1 Environment Test

Contents	Condition	Remark
High temperature Storage	+125°C±5°C, 240 hr	*Testing is complete, leave at room temperature for 24 hours, and Measure.(25°C±5°C) * Be satisfied with contents No 2. Specification
Low temperature Storage	-55°C±5°C, 240 hr	
High temperature High humidity Storage	+85°C±5°C, RH=85%, 96 hr	
PCT	+121°C±5°C, RH=100%, 24hr	

5.2 Thermal shock , Reflow Test

Contents	Condition	Remark
Thermal shock	-40°C±5°C,+90°C±5°C, 15 min, 300 cycle	*Testing is complete, leave at room temperature for 24 hours, and Measure.(25°C±5°C) * Be satisfied with contents No 2. Specification
REFLOW	Pre Heating 200±5°C , 30~60 sec Peak Heating 260°C±5°C , 30sec Max	

5.3 Mechanical Test

Contents	Condition	Remark
Vibration	Frequency : 10~500Hz, 10 ×9.8m/s ² (G) Sweep time 15min ,X.Y.Z each 5 times	*Testing is complete, leave at room temperature for 1 hours, and Measure.(25°C±5°C) * Be satisfied with contents No 2. Specification
Drop test	12 times falling at a 160cm height (falling with jig)	

5.4 Table

Frequency change permitted	±3ppm Max.
----------------------------	------------

6. Soldering Condition

6.1 Standard Reflow soldering condition

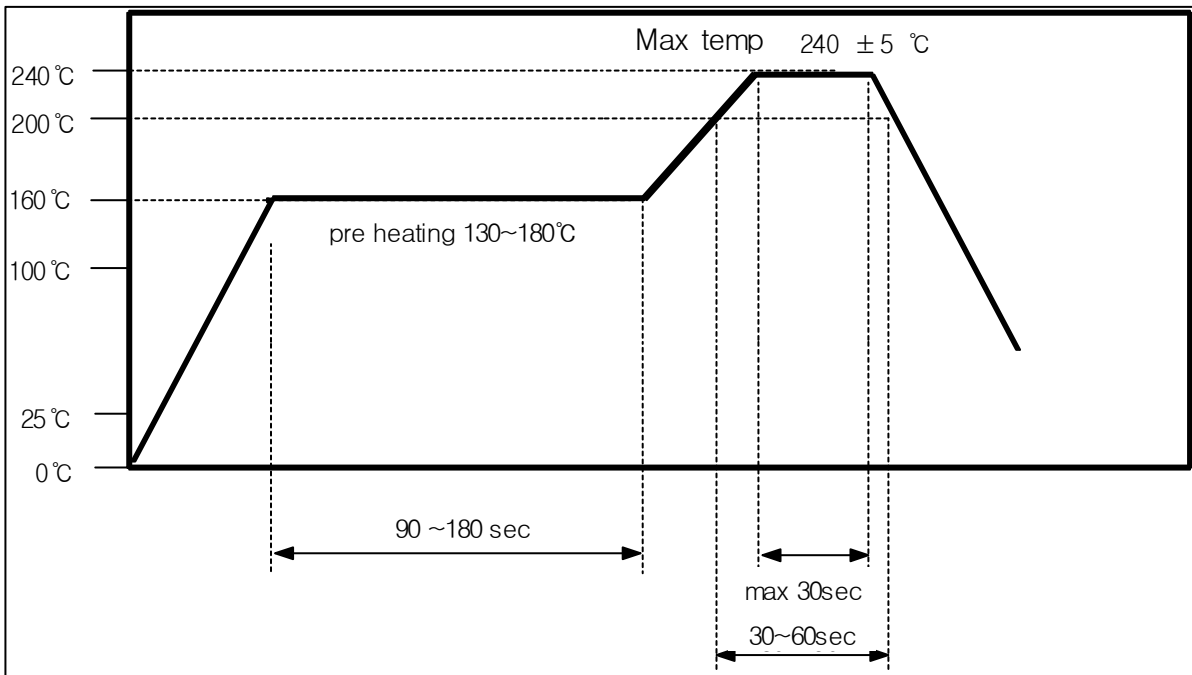

6.2 The maximum temperature guarantees to the 260°C (10sec Max)

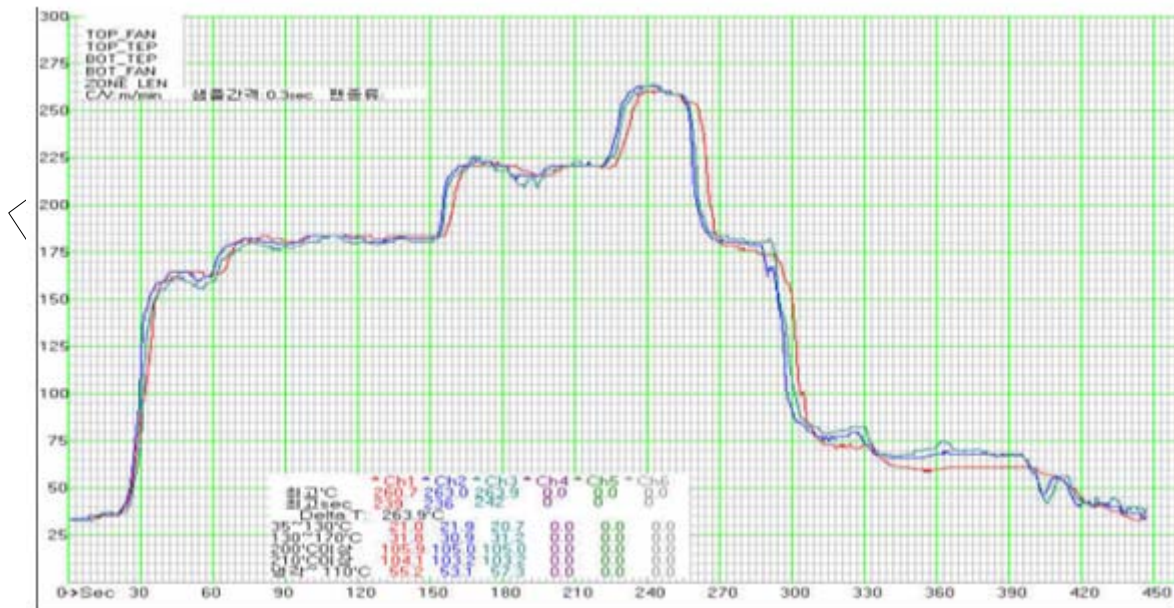

6.3 Soldering Iron Method

- Pre heating : 120°C (30 ~ 300 sec)
- Max temp : 410°C Max
- Time : Max 4 sec

7. Construction

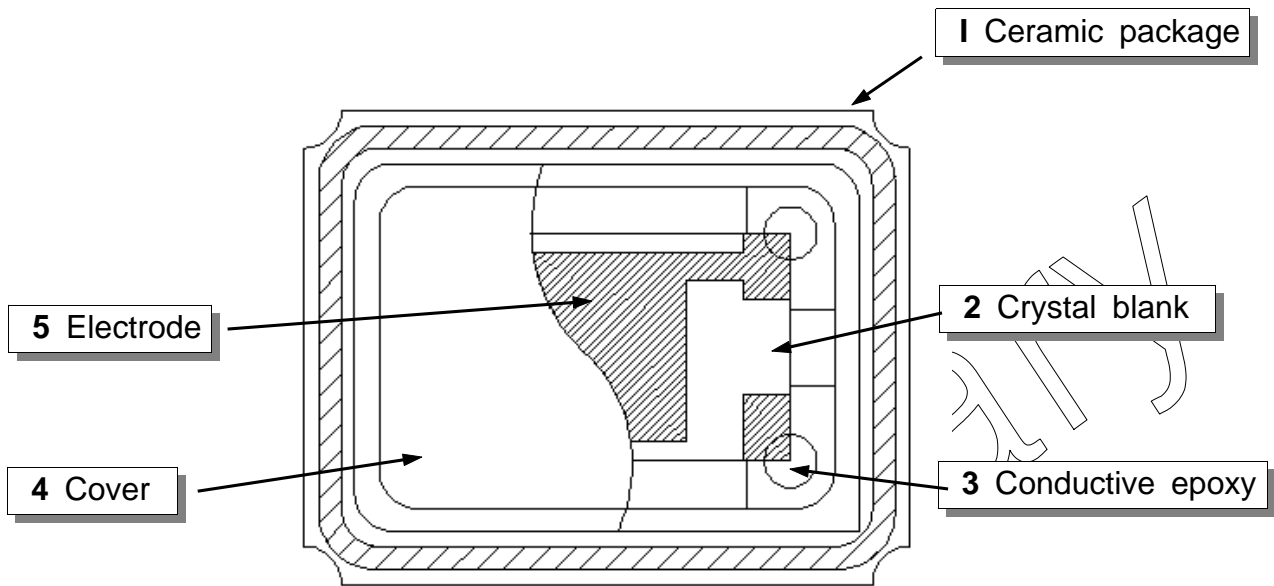

No	item
1	Ceramic package
2	Crystal blank
3	Conductive Epoxy
4	Lid(Cover)
5	Electrode

8. Notices

8.1 Max. two(2) times reflow is allowed.

Once miss soldering is happen, hand work soldering by soldering iron is recommended.
(+400°C x within 5 sec)

8.2 Ultrasonic vibration may cause deterioration and destruction of the components.

Please avoid ultrasonic cleaning

8.3 We recommend storing products at +15°C to +35°C and 25% R.H to 75% R.H

8.4 ESD Level : Class2(2000V ~ 4000V)

8.5 MSL LEVEL 1 (JEDEC J-STD-020C)

ITEM	Floor Life		Soak Requirements	
	Time	Conditions	Time	Conditions
1	Unlimited	=< 30°C/85%RH	165hr	=< 85°C/85%RH

8.6 Unless adequate negative resistance is allocated in the oscillation circuit, start up time of oscillation may be increased, or no oscillation may occur. In order to avoid this, please provide enough negative resistance in the circuit design.

© How to check the negative resistance

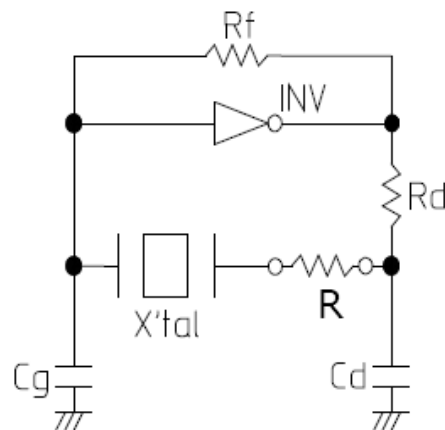

(1) Connect the resistor (R) to the circuit in series with the crystal resonator.

(2) Adjust R so that oscillation can start (or stop).

(3) Measure R when oscillation just start (or stop) in above (2).

(4) Get the negative resistance

$$-R = R + CI \text{ value}$$

(5) Recommended -R

$$[-R] > CI \times 5$$

9. Packing

9.1 Reel, carrier tape material

item	Main Material
Cover Tape	PE (Polyester film)
Carrier Tape	PC (Poly Carbonate +Carbon) or (Clear Poly Carbonate)
Reel	PS (Poly Styrene)

9.2 inner Box :1 reel/inner box and 2,000 pcs or 3,000 pcs /1 reel.

9.3 Outer Box : 10 inner boxes/Outer Box

Max 30,000 pcs are packed in a 1 outer box

9.4 Reel and Carrier tape dimensions(unit : mm)

■ Carrier tape

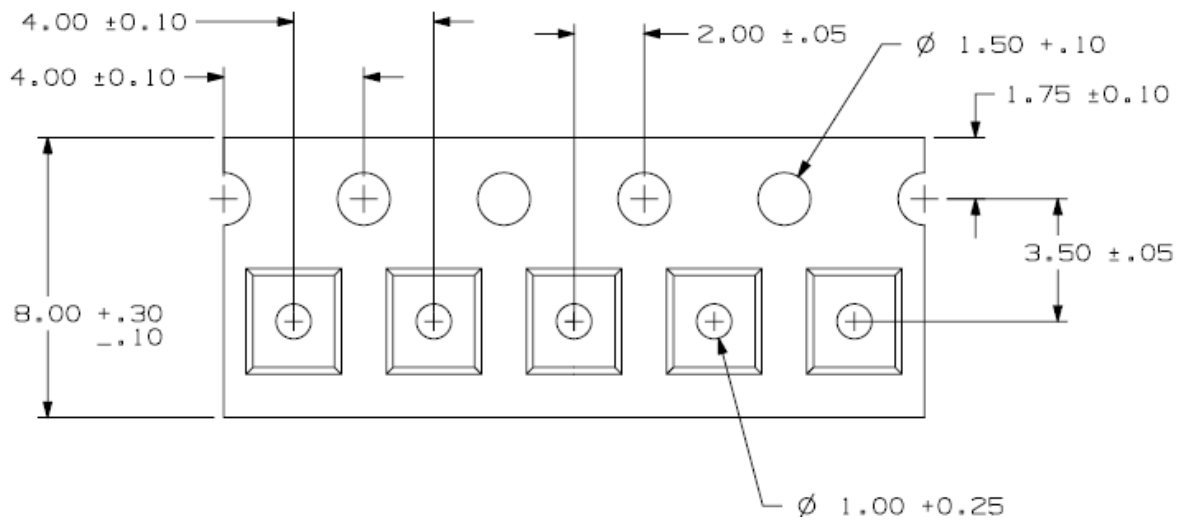

*Heating press cover tape

9.5 Reel Dimensions (unit : mm)

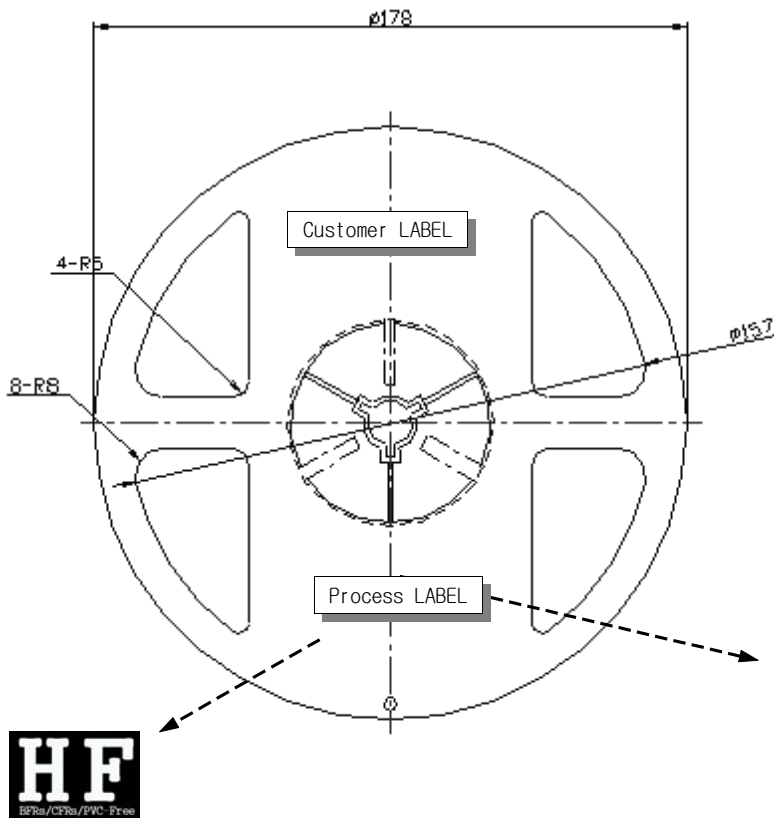
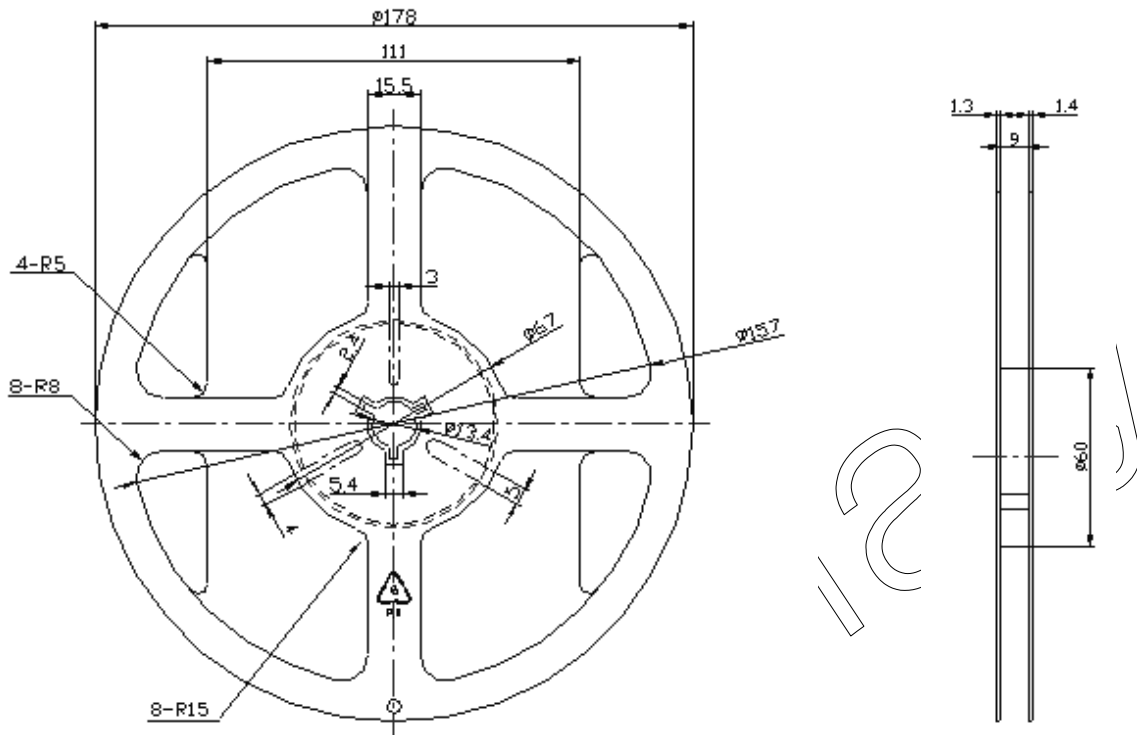

9.6 Tape and Reel

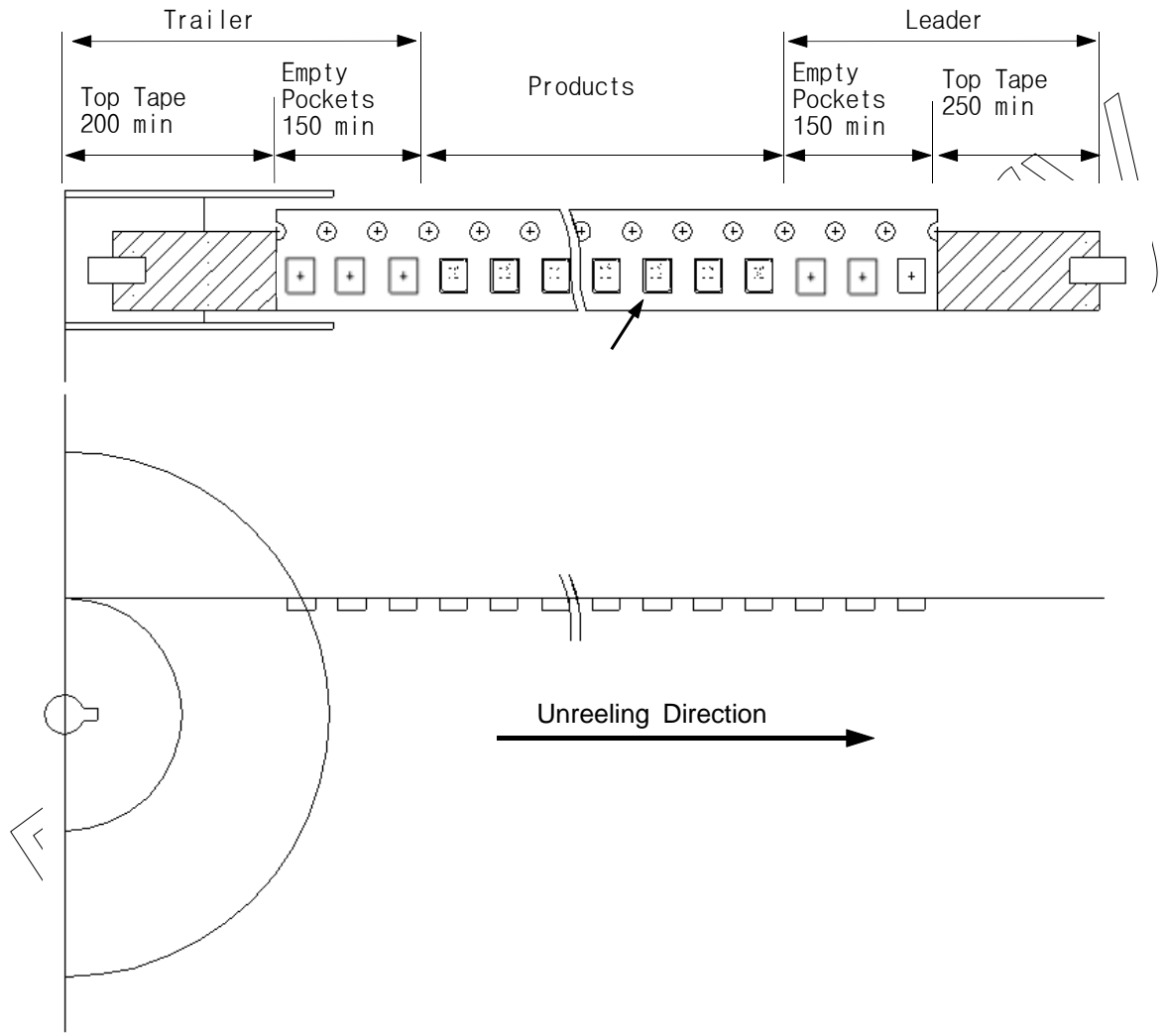

9.7 Inner, outer box Dimensions (unit : mm)

