

SMD ■ MID POWER LED

62-217B/XK2C-SXXXXXXXXXXZ15/2T



Features

- PLCC-4 Package
- Top view white LED
- High luminous flux output
- High current capability
- Wide viewing angle
- Pb-free
- RoHS compliant
- ANSI Binning

Description

The Everlight 0.5W 62-217B package has high efficacy, high CRI, low power consumption, wide viewing angle and a compact form factor. These features make this package an ideal LED for all lighting application.

Applications

- Decorative and Entertainment Lighting
- Light pipe application
- Indicator and backlight in office and family equipment
- General use

Product Number Explanation

62-217B / XK 2 C - S XX XX XX XX XX Z15/ 2T



Table of Color Rendering Index

Symbol	Description
M	CRI(Min.) : 60
N	CRI(Min.) : 65
L	CRI(Min.) : 70
Q	CRI(Min.) : 75
K	CRI(Min.) : 80
H	CRI(Min.) : 90

Notes:

Tolerance of Color Rendering Index: ±2

Table of Forward Current Index

Symbol	Description
Z15	I _F :150mA

Example:

62-217B/QK2C-S5757R1R3B42Z15/2T

CRI	75(Min.)
CCT	5700K
Flux	50~65lm
V _F	2.8V~3.5V
I _F	150mA

Mass Production list

Product	CRI Min.	CCT(K)	Φ(lm) Min.	Φ(lm) Typ.	Φ(lm) Max.
62-217B/QK2C-S6565R1R3B42Z15/2T	75	6500K	50	55	65
62-217B/QK2C-S5757QAR1B42Z15/2T	75	5700K	45	50	55
62-217B/QK2C-S5757R1R3B42Z15/2T	75	5700K	50	55	65
62-217B/QK2C-S5757R2R4B42Z15/2T	75	5700K	55	60	70
62-217B/QK2C-S5050R1R3B42Z15/2T	75	5000K	50	55	65
62-217B/QK2C-S4040QAR1B42Z15/2T	75	4000K	45	50	55

Mass Production list

Product	CRI Min.	CCT(K)	Φ(lm) Min.	Φ(lm) Typ.	Φ(lm) Max.
62-217B/KK2C-S4040QAR2B42Z15/2T	80	4000K	45	50	60
62-217B/KK2C-S3030PBQAB42Z15/2T	80	3000K	40	45	50
62-217B/KK2C-S3030QAR2B42Z15/2T	80	3000K	45	50	60
62-217B/KK2C-S2727PAQAB42Z15/2T	80	2700K	36	40	50

Notes:
 Tolerance of Luminous flux: ±11%.

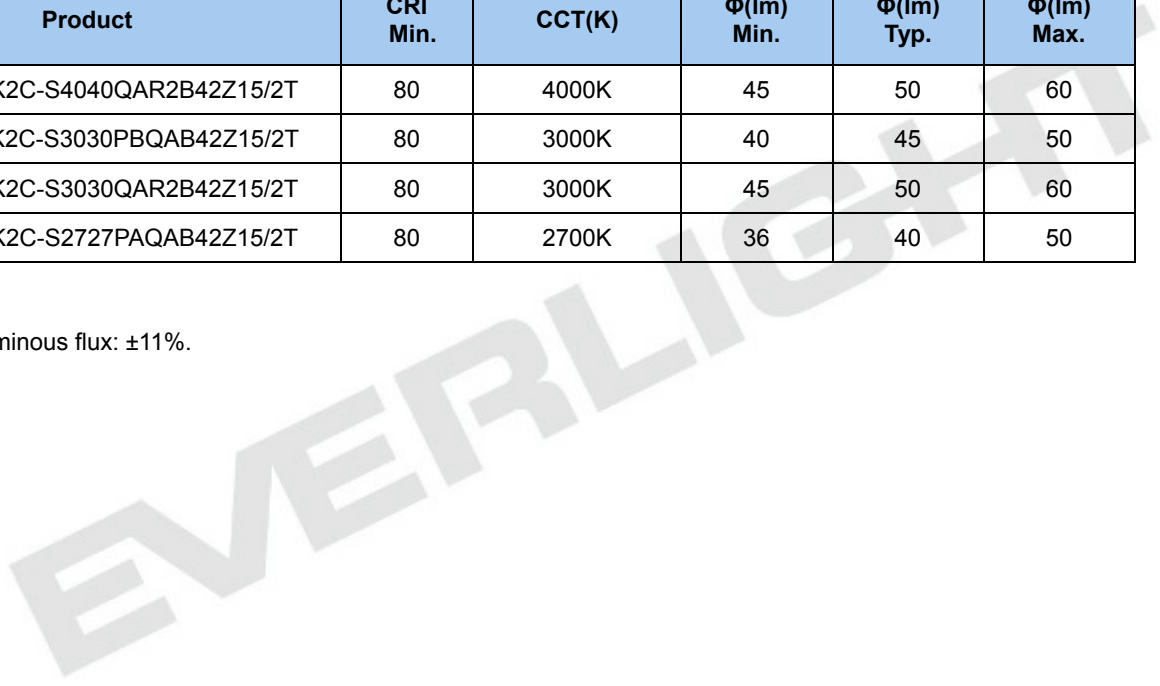

Device Selection Guide

Chip Materials	Emitted Color	Resin Color
InGaN	Cool White Neutral White Warm White	Water Clear

Absolute Maximum Ratings (T_{Soldering}=25)

Parameter	Symbol	Rating	Unit
Forward Current	I _F	180	mA
Peak Forward Current (Duty 1/10 @10ms)	I _{FP}	300	mA
Power Dissipation	P _d	670	mW
Electrostatic Discharge(HBM)	ESD	2000	V
Operating Temperature	T _{opr}	-40 ~ +85	
Storage Temperature	T _{stg}	-40 ~ +100	
Thermal Resistance (Junction / Soldering point)	R _{th J-S}	26	/W
Junction Temperature	T _j	115	
Soldering Temperature	T _{sol}	Reflow Soldering : 260 Hand Soldering : 350	for 10 sec. for 3 sec.

Electro-Optical Characteristics (T_{Soldering}=25)

Parameter	Symbol	Min.	Typ.	Max.	Unit	Condition
Luminous Flux	Φ	36	-----	70	lm	I _F =150mA
Forward Voltage	V _F	2.8	-----	3.5	V	I _F =150mA
Viewing Angle	2θ _{1/2}	-----	120	-----	deg	I _F =150mA

Notes:

1. Tolerance of Luminous flux: ±11%.
2. Tolerance of Forward Voltage : ±0.1V.

Bin Range of Luminous Flux

Bin Code	Min.	Max.	Unit	Condition
PA	36	40	lm	I _F =150mA
PB	40	45		
QA	45	50		
R1	50	55		
R2	55	60		
R3	60	65		
R4	65	70		

Notes:
 Tolerance of Luminous flux: ±11%

Bin Range of Forward Voltage

Group	Bin Code	Min.	Max.	Unit	Condition
B42	35	2.8	2.9	V	I _F =150mA
	36	2.9	3.0		
	37	3.0	3.1		
	38	3.1	3.2		
	39	3.2	3.3		
	40	3.3	3.4		
	41	3.4	3.5		

Notes:
 Tolerance of Forward Voltage : ±0.1V.

Electro-Optical Characteristics

Warm White

If (mA)	Vf(V)	Power(W)	Flux(lm)	Lm/W
50	2.80	0.14	18.3	130.7
100	2.93	0.29	32.6	112.4
120	3.06	0.37	40.1	109.2
150	3.13	0.47	47.9	102.0
180	3.20	0.58	54.9	95.3

Cool White

If (mA)	Vf(V)	Power(W)	Flux(lm)	Lm/W
50	2.79	0.14	20.2	144.3
100	2.96	0.29	35.3	121.7
120	3.08	0.37	42.8	115.6
150	3.11	0.47	51.3	109.2
180	3.23	0.58	59.5	102.6

Notes:
Data is only for reference..

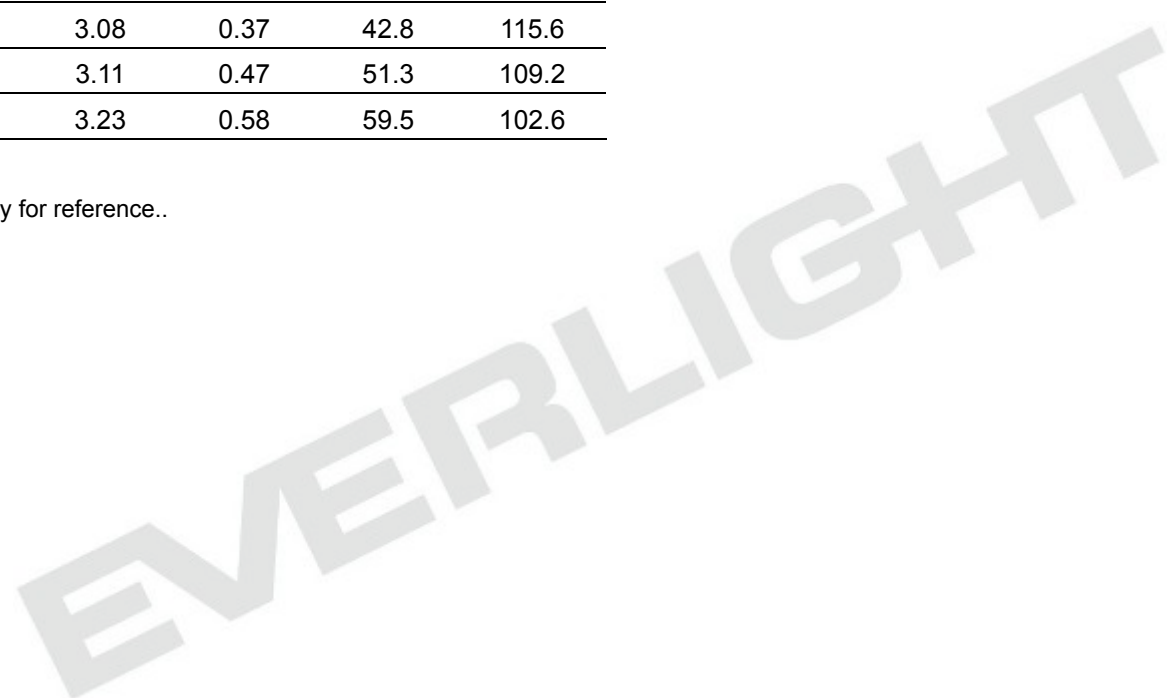

Bin Range of Chromaticity Coordinate

CCT	Bin Code	CIE_x	CIE_y	Bin Code	CIE_x	CIE_y
5700K	57K-1	0.3376	0.3616	57K-3	0.3293	0.3423
		0.3292	0.3539		0.3215	0.3353
		0.3293	0.3423		0.3222	0.3243
		0.3371	0.3493		0.3294	0.3306
	57K-2	0.3292	0.3539	57K-4	0.3371	0.3493
		0.3207	0.3462		0.3293	0.3423
		0.3215	0.3353		0.3294	0.3306
		0.3293	0.3423		0.3366	0.3369
4000K	40K-1	0.4006	0.4044	40K-3	0.3828	0.3803
		0.3871	0.3959		0.3703	0.3726
		0.3828	0.3803		0.3670	0.3578
		0.3952	0.3880		0.3784	0.3647
	40K-2	0.3871	0.3959	40K-4	0.3952	0.3880
		0.3736	0.3874		0.3828	0.3803
		0.3703	0.3726		0.3784	0.3647
		0.3828	0.3803		0.3898	0.3716
3000K	30K-1	0.4562	0.4260	30K-3	0.4345	0.4033
		0.4431	0.4213		0.4223	0.3990
		0.4345	0.4033		0.4147	0.3814
		0.4468	0.4077		0.4260	0.3854
	30K-2	0.4431	0.4213	30K-4	0.4468	0.4077
		0.4299	0.4165		0.4345	0.4033
		0.4223	0.3990		0.4260	0.3854
		0.4345	0.4033		0.4373	0.3893
2700K	27K-1	0.4813	0.4319	27K-3	0.4585	0.4104
		0.4688	0.4290		0.4468	0.4077
		0.4585	0.4104		0.4373	0.3893
		0.4703	0.4132		0.4483	0.3919
	27K-2	0.4688	0.4290	27K-4	0.4703	0.4132
		0.4562	0.4260		0.4585	0.4104
		0.4468	0.4077		0.4483	0.3919
		0.4585	0.4104		0.4593	0.3944

Notes:

1. The value are based on driving current by 150mA.
2. Tolerance of Chromaticity Coordinates : ±0.01.

The C.I.E. 1931 Chromaticity Diagram

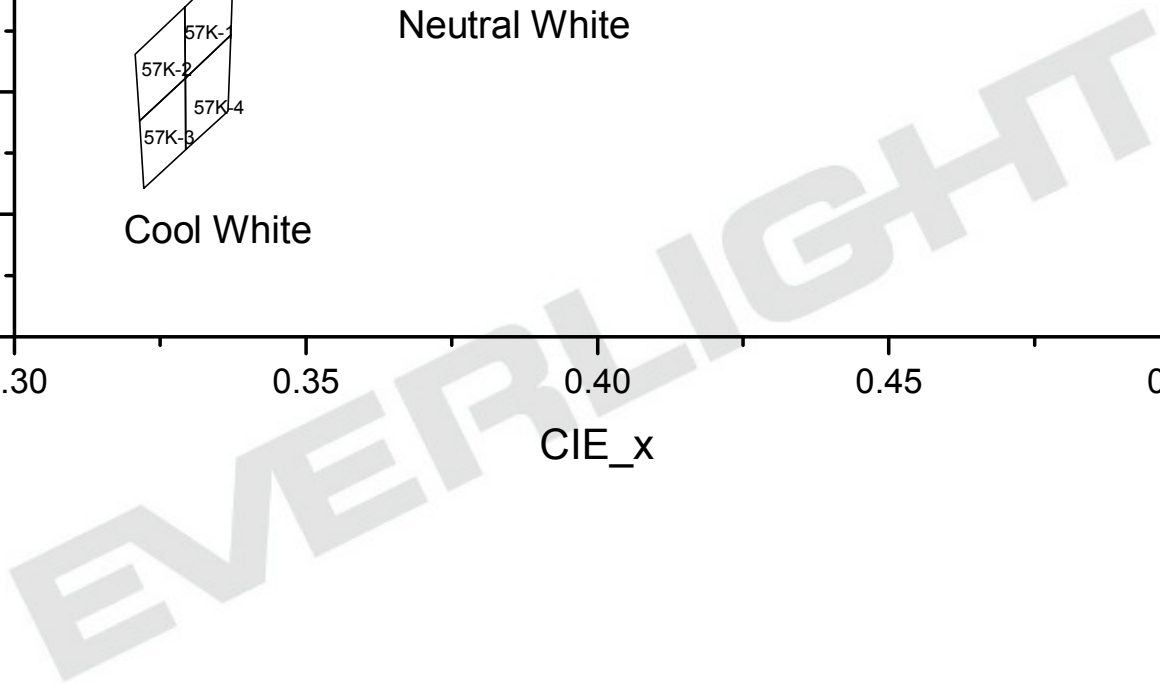
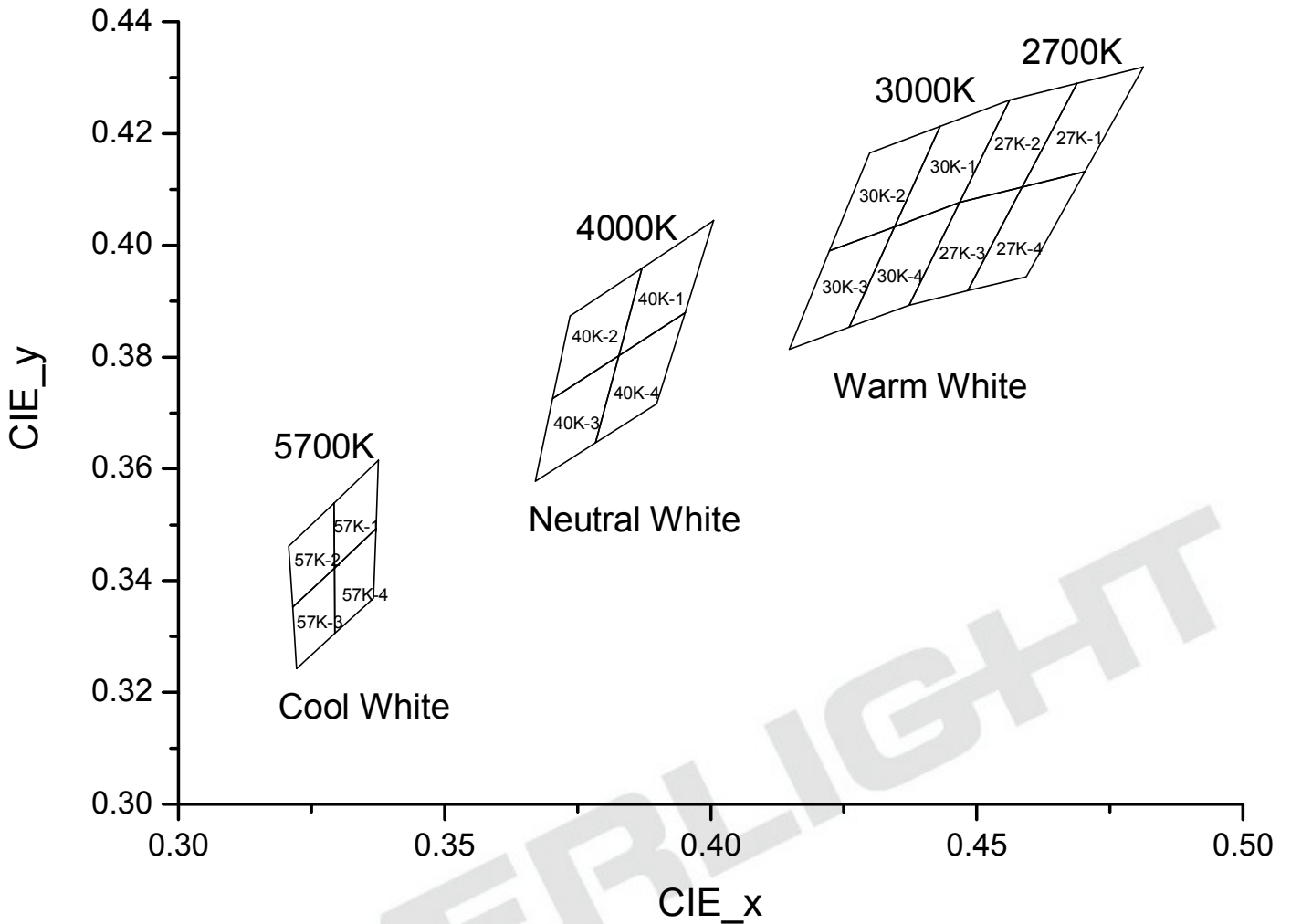

Spectrum Distribution

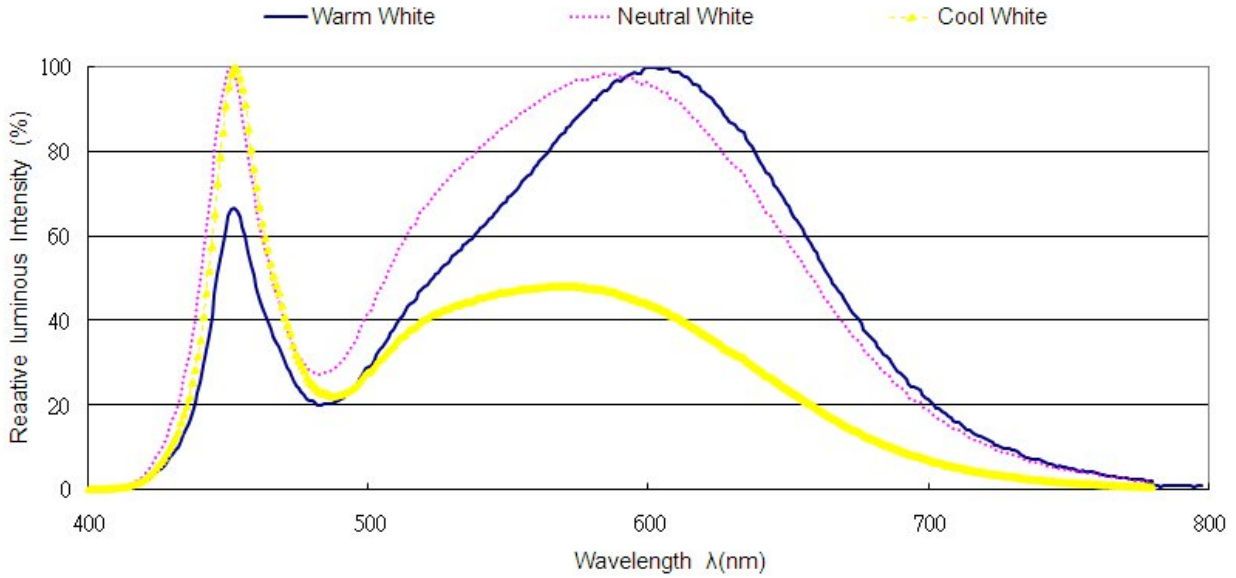

Typical Electro-Optical Characteristics Curves

Fig.1 – Forward Voltage Shift vs. Junction Temperature

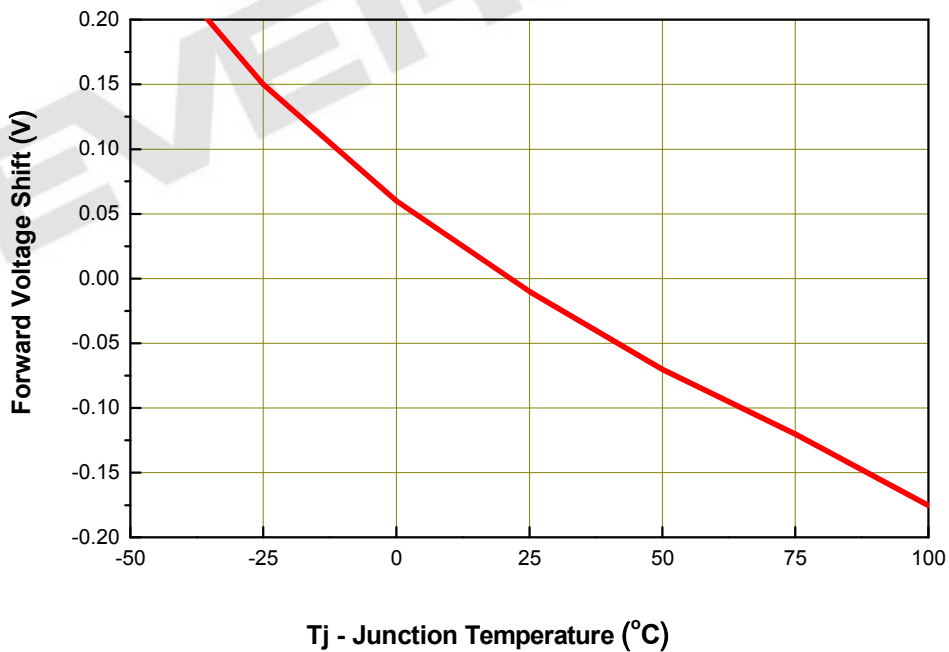

Fig.2 - Relative Luminous Intensity vs. Forward Current

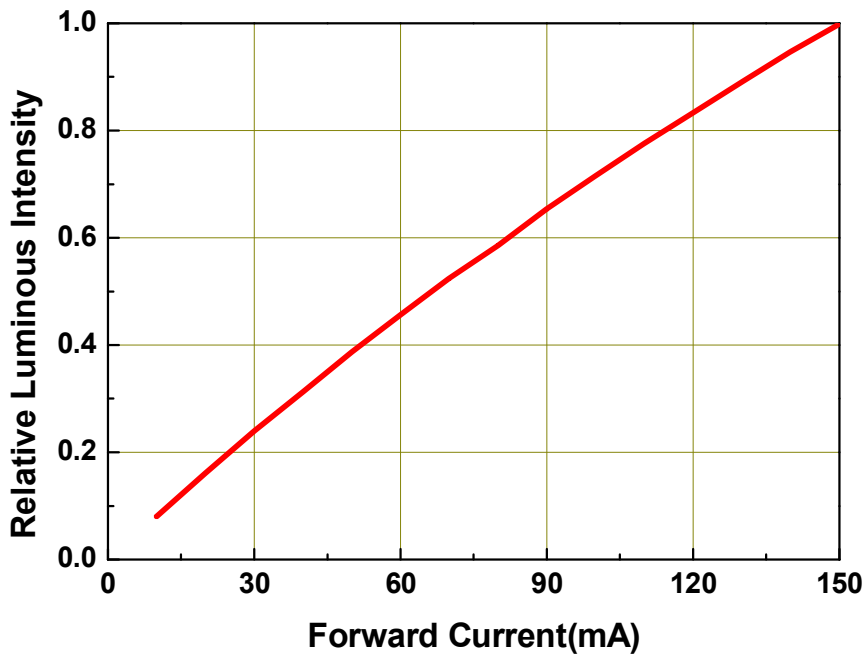

Fig.3 - Relative Luminous Intensity vs. Junction Temperature

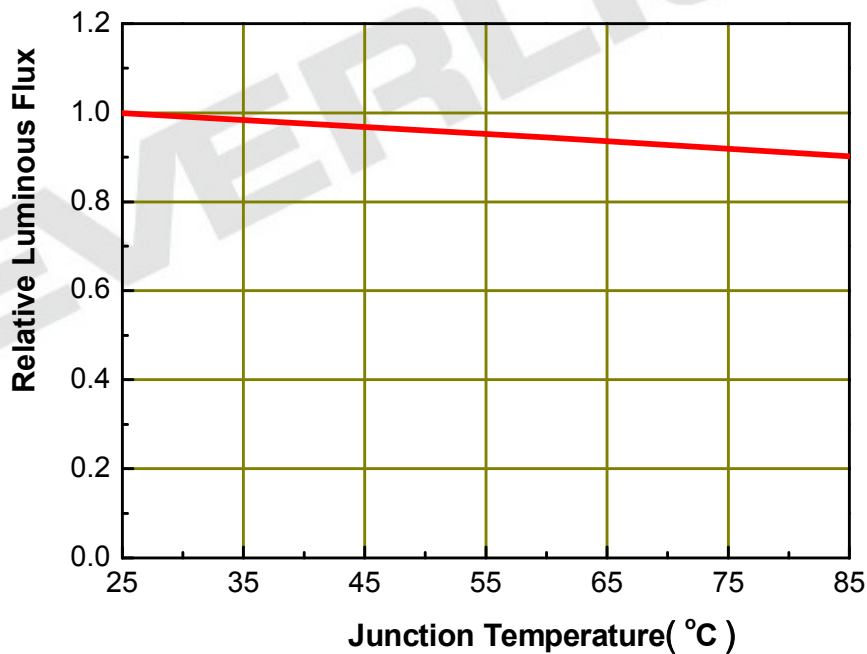

Fig.4 - Forward Current vs.
Forward Voltage

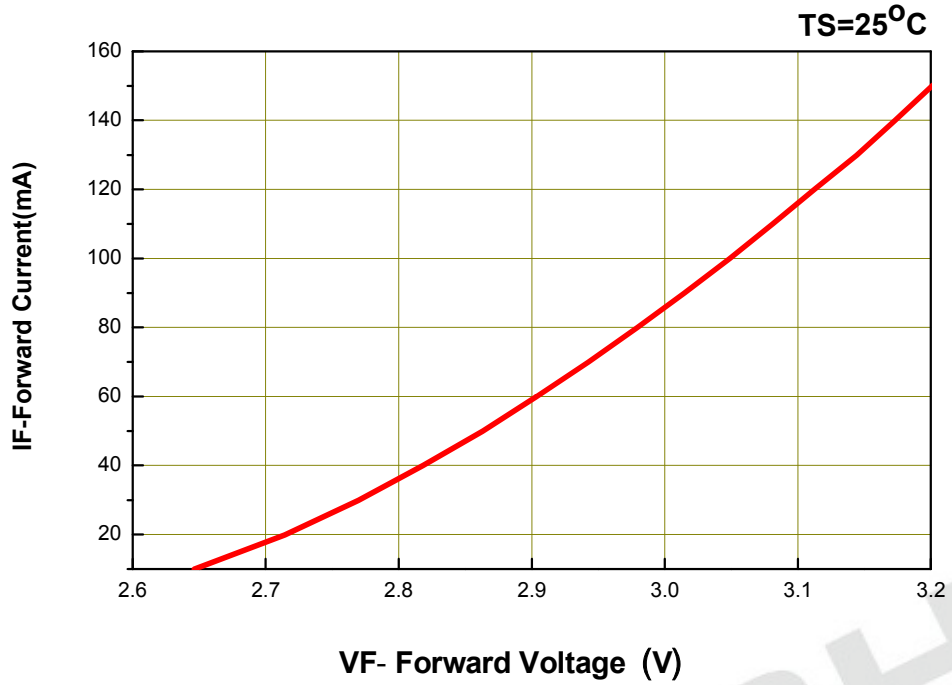

Fig.5 – Max. Driving Forward Current
vs. Soldering Temperature

Rth j-s=26° C/W

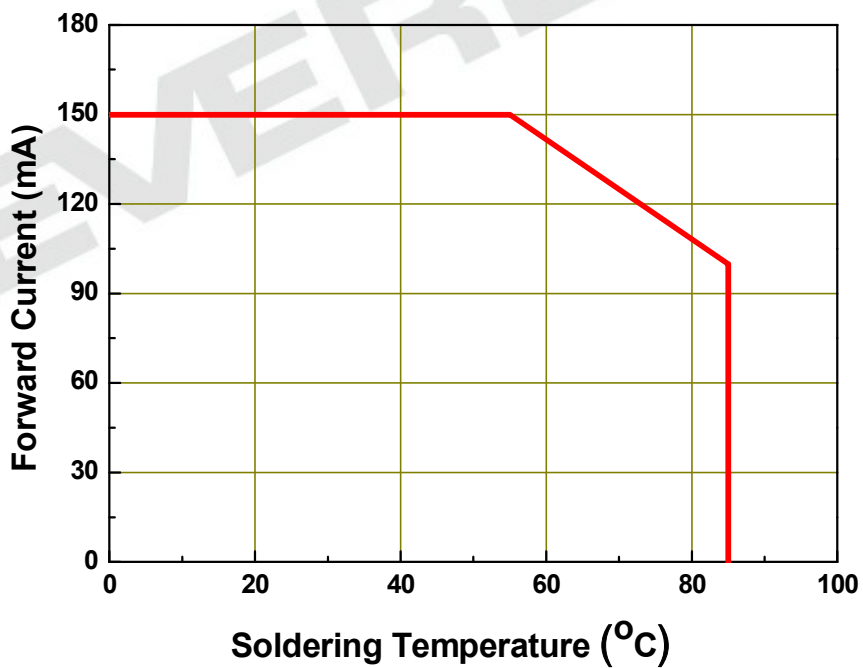
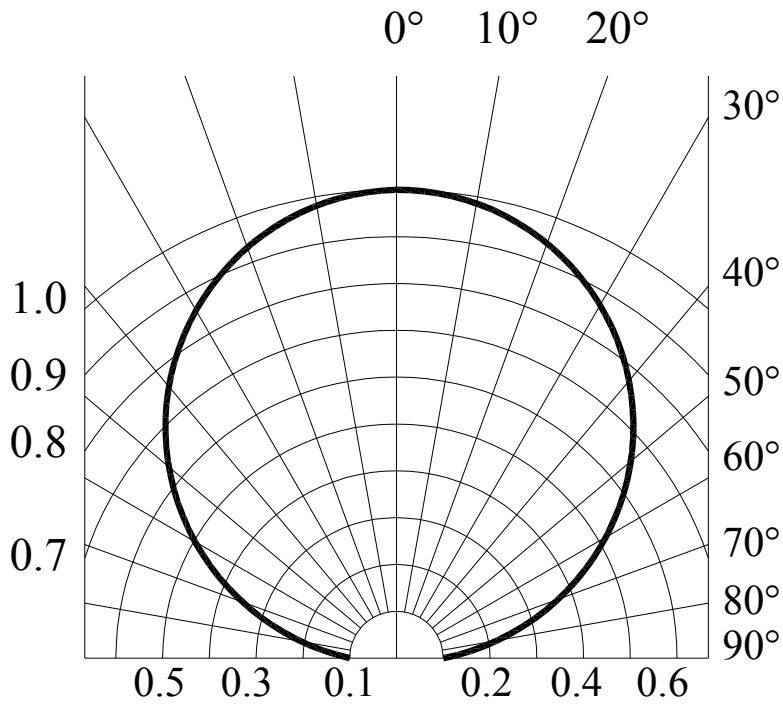
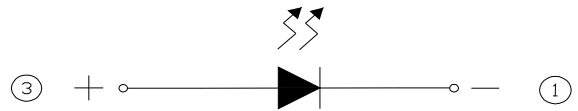
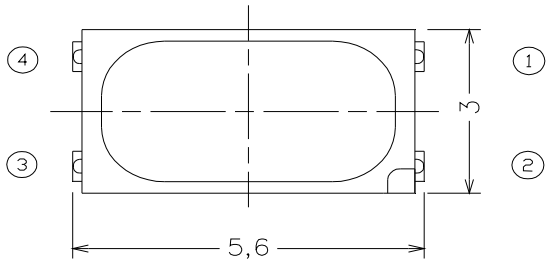

Fig.6 - Radiation Diagram



Package Dimension



Polarity

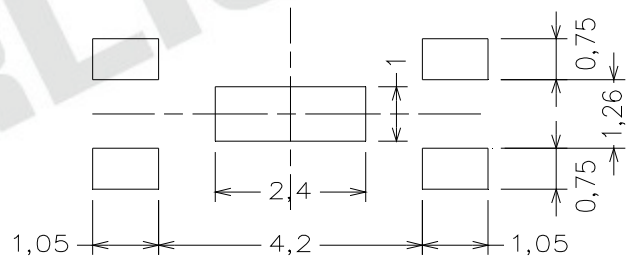
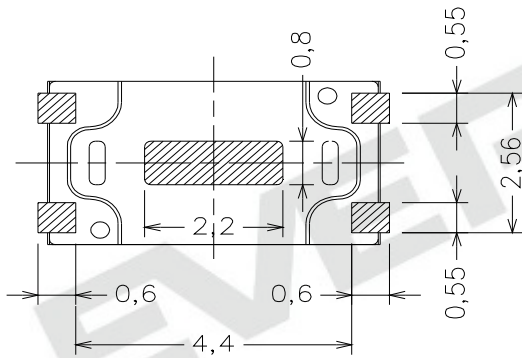
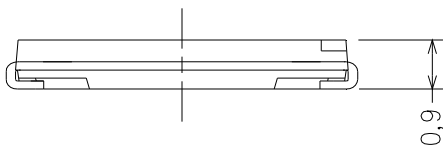

Note:
 Tolerance unless mentioned is $\pm 0.2\text{mm}$; Unit = mm

Moisture Resistant Packing Materials

Label Explanation



- CPN: Customer's Product Number
- P/N: Product Number
- QTY: Packing Quantity
- CAT: Luminous Intensity Rank
- HUE: Dom. Wavelength Rank
- REF: Forward Voltage Rank
- LOT No: Lot Number

Reel Dimensions

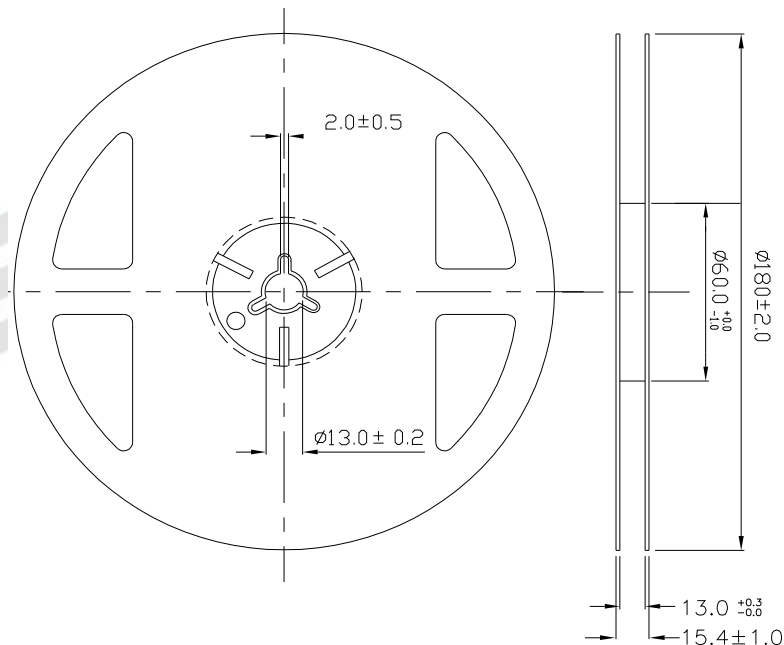

Note:
 Tolerances unless mentioned ±0.1mm. Unit = mm

Carrier Tape Dimensions: Loaded Quantity 2000 pcs Per Reel

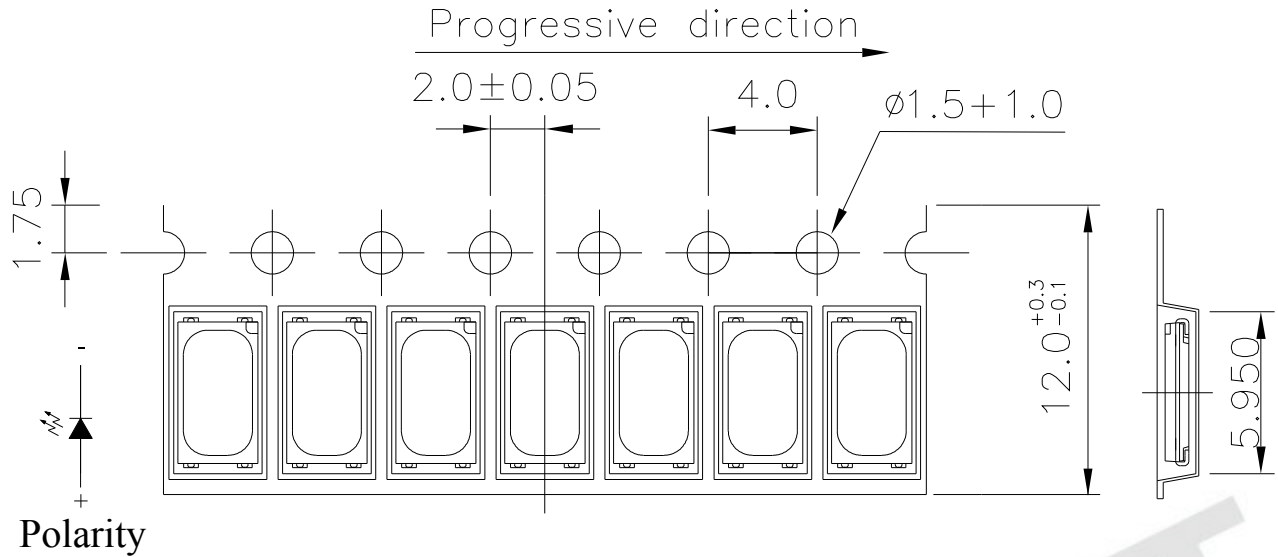

Note:
 Tolerances unless mentioned ± 0.1 mm. Unit = mm

Moisture Resistant Packing Process

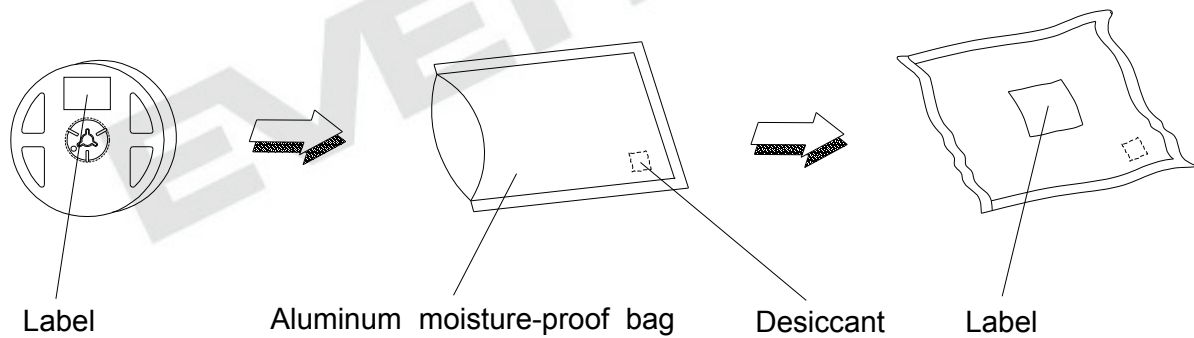

Reliability Test Items and Conditions

The reliability of products shall be satisfied with items listed below.

Confidence level : 90%

LTPD : 10%

No.	Items	Test Condition	Test Hours/Cycles	Sample Size	Ac/Re
1	Reflow Soldering	Temp. : 260 /10sec.	6 Min.	22 PCS.	0/1
2	Thermal Shock	H : +100 5min 10 sec L : -10 5min	200 Cycles	22 PCS.	0/1
3	Temperature Cycle	H : +100 15min 5 min L : -40 15min	200 Cycles	22 PCS.	0/1
4	High Temperature/Humidity Storage	Ta=85 ,85%RH	1000 Hrs.	22 PCS.	0/1
5	High Temperature/Humidity Operation	Ta=85 ,85%RH, I _F = 100 mA	1000 Hrs.	22 PCS.	0/1
6	Low Temperature Storage	Ta=-40	1000 Hrs.	22 PCS.	0/1
7	High Temperature Storage	Ta=85	1000 Hrs.	22 PCS.	0/1
8	Low Temperature Operation Life	Ta=-40 , I _F = 180 mA	1000 Hrs.	22 PCS.	0/1
9	High Temperature Operation/ Life#1	Ta=25 , I _F = 180 mA	1000 Hrs.	22 PCS.	0/1
10	High Temperature Operation/ Life#2	Ta=55 , I _F =180 mA	1000 Hrs.	22 PCS.	0/1
11	High Temperature Operation/ Life#3	Ta=85 , I _F = 100 mA	1000 Hrs.	22 PCS.	0/1

Precautions for Use

1. Over-current-proof

Customer must apply resistors for protection; otherwise slight voltage shift will cause big current change (Burn out will happen).

2. Storage

2.1 Do not open moisture proof bag before the products are ready to use.

2.2 Before opening the package: The LEDs should be kept at 30 °C or less and 90%RH or less.

2.3 After opening the package: The LED's floor life is 72 Hrs under 30 °C or less and 60% RH or less. If unused LEDs remain, it should be stored in moisture proof packages.

2.4 If the moisture absorbent material (silica gel) has faded away or the LEDs have exceeded the storage time, baking treatment should be performed using the following conditions.

Baking treatment: 60±5 °C for 24 hours.

3. Soldering Condition

3.1 Pb-free solder temperature profile

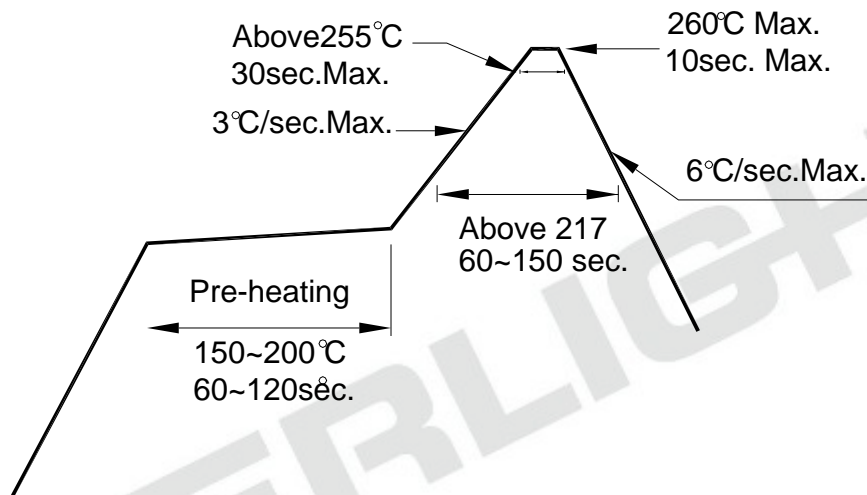

3.2 Reflow soldering should not be done more than two times.

3.3 When soldering, do not put stress on the LEDs during heating.

3.4 After soldering, do not warp the circuit board.

4. Soldering Iron

Each terminal is to go to the tip of soldering iron temperature less than 350 for 3 seconds within once in less than the soldering iron capacity 25W. Leave two seconds and more intervals, and do soldering of each terminal. Be careful because the damage of the product is often started at the time of the hand solder.

5. Repairing

Repair should not be done after the LEDs have been soldered. When repairing is unavoidable, a double-head soldering iron should be used (as below figure). It should be confirmed beforehand whether the characteristics of the LEDs will or will not be damaged by repairing.

