

## Quasi-Resonant Primary Side Regulation CV/CC Power Switch

### FEATURES

- Built-in 800V High Voltage Power BJT
- Quasi-Resonant Primary Side Regulation (QR-PSR) Control with High Efficiency
- Multi-Mode PSR Control
- Fast Dynamic Response
- Built-in Dynamic Base Drive
- Audio Noise Free Operation
- $\pm 4\%$  CC and CV Regulation
- Low Standby Power <70mW
- Programmable Cable Drop Compensation (CDC) in CV Mode
- Built-in AC Line & Load CC Compensation
- Build in Protections:
  - Short Load Protection (SLP)
  - Cycle-by-Cycle Current Limiting (OCP)
  - Leading Edge Blanking (LEB)
  - On-Chip Thermal Shutdown (OTP)
  - VDD OVP & UVP & Clamp
- Available in SOP-7 Package

### APPLICATIONS

- Battery Chargers for Cellular Phones
- AC/DC Power Adapter and LED Lightings

### TYPICAL APPLICATION CIRCUIT

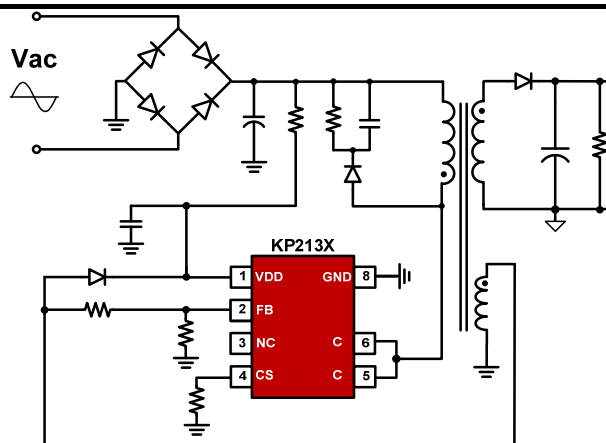

### GENERAL DESCRIPTION

KP213X is a high performance Quasi Resonant (QR) Primary Side Regulation (PSR) PWM power switch with high precision CV/CC control ideal for charger applications.

In CV mode, KP213X adopts Multi Mode QR Control which uses the hybrid of AM (Amplitude Modulation) mode and (Frequency Modulation) FM mode to improve system efficiency and reliability. In CC mode, the IC uses PFM control with line and load CC compensation. The IC can achieve fast dynamic response. The built-in Cable Drop Compensation (CDC) function can provide excellent CV performance.

KP213X integrates functions and protections of Under Voltage Lockout (UVLO), VDD over Voltage Protection (VDD OVP), Cycle-by-cycle Current Limiting (OCP), Short Load Protection (SLP), On-Chip Thermal Shutdown, VDD Clamping, etc.

### Pin Configuration

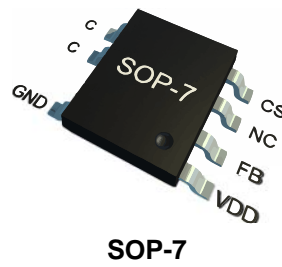

### Marking Information

XXXXXX: Wafer Lot Code  
Y: Year, G for 2017  
WW: Working Week, 01-52

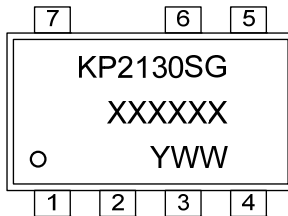

XXXXXX: Wafer Lot Code  
Y: Year, G for 2017  
WW: Working Week, 01-52

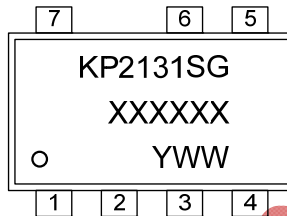

XXXXXX: Wafer Lot Code  
Y: Year, G for 2017  
WW: Working Week, 01-52

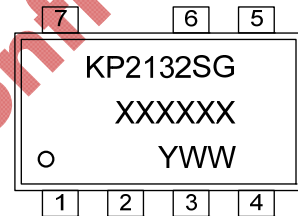

### Output Power Table <sup>(1)</sup>

Part Number	230VAC ± 15% <sup>(2)</sup>	85-265VAC
	Adapter <sup>(3)</sup>	Adapter <sup>(3)</sup>
KP2130	6.5W	5W
KP2131	10W	8W
KP2132	12W	10W

**Note 1.** The Max. output power is limited by junction temperature.

**Note 2.** 230VAC or 100/115VAC with doublers.

**Note 3.** Typical continuous power in a non-ventilated enclosed adapter with sufficient drain pattern as a heat sink at 50°C ambient.

### Pin Description

Pin Number	Pin Number	I/O	Description
1	VDD	P	IC Power supply pin
2	FB	I	System feedback and Quasi-Resonant Detection Pin
3	NC	-	No connect
4	CS	I	Current Sense Input Pin
5,6	C	P	Internal power BJT collector pin
7	GND	P	IC ground pin

### Ordering Information

Part Number	Description
KP2130SGA	SOP-7, Halogen free, in T&R, 4000Pcs/Reel
KP2131SGA	SOP-7, Halogen free, in T&R, 4000Pcs/Reel
KP2132SGA	SOP-7, Halogen free, in T&R, 4000Pcs/Reel

### Block Diagram

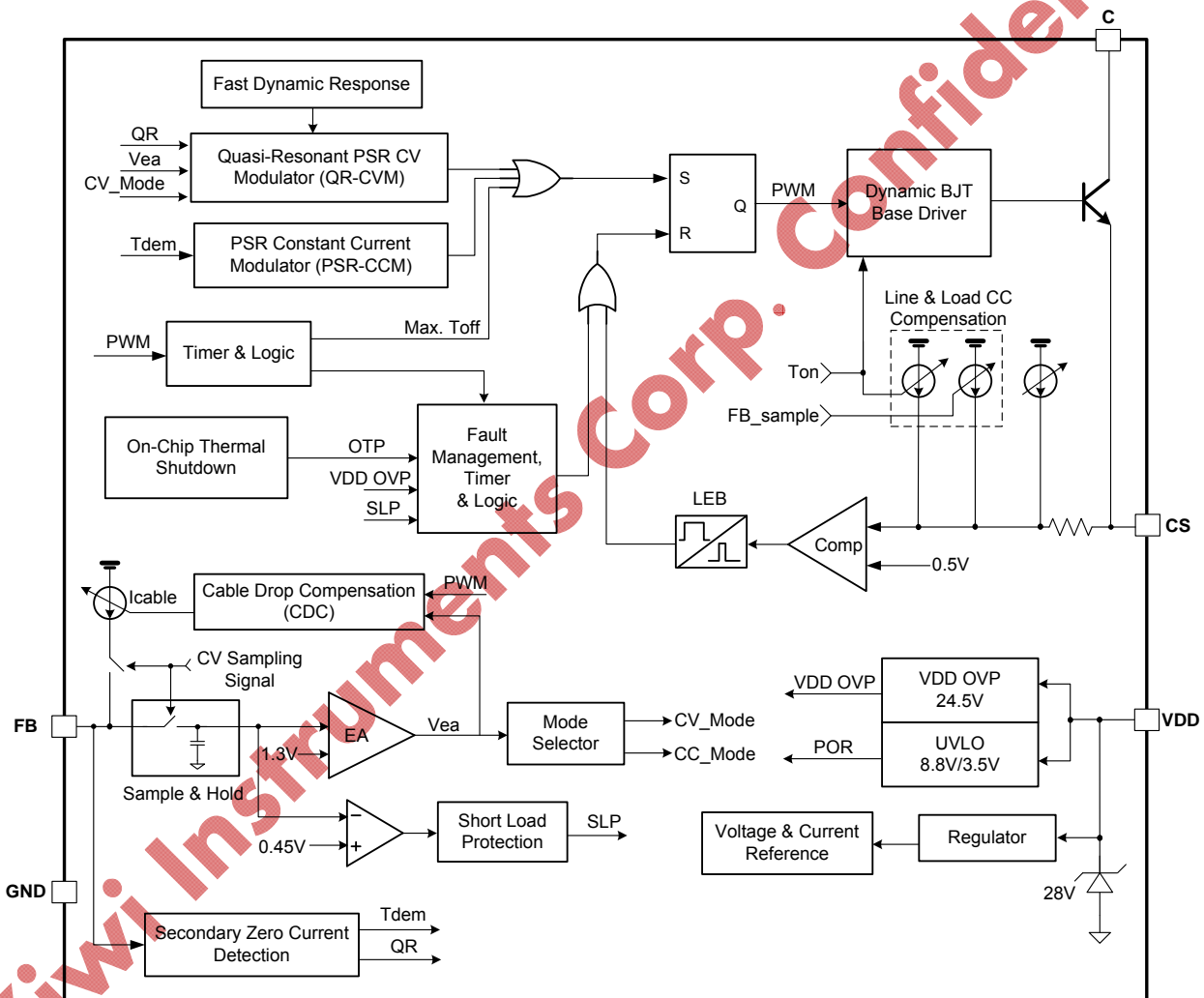

**Absolute Maximum Ratings (Note 1)**

Parameter	Value	Unit
C Pin Voltage Range	-0.3 to 800	V
VDD DC Supply Voltage	30	V
VDD DC Clamp Current	10	mA
CS Voltage Range	-0.3 to 7	V
FB Voltage Range	-0.7 to 7	V
Package Thermal Resistance (SOP-7)	165	°C/W
Maximum Junction Temperature	165	°C
Storage Temperature Range	-65 to 150	°C
Lead Temperature (Soldering, 10sec.)	260	°C
ESD Capability, HBM (Human Body Model)	3	kV
ESD Capability, MM (Machine Model)	250	V

**Recommended Operation Conditions (Note 2)**

Parameter	Value	Unit
Supply Voltage, VDD	5 to 23	V
Operating Ambient Temperature	-40 to 85	°C
Maximum Switching Frequency @ Full Loading	70	kHz
Minimum Switching Frequency @ Full Loading	35	kHz

**Electrical Characteristics (T<sub>A</sub>= 25°C, VDD=20V, if not otherwise noted)**

Symbol	Parameter	Test Conditions	Min	Typ.	Max	Unit
<b>Supply Voltage Section (VDD Pin)</b>						
I <sub>VDD_st</sub>	Start-up current into VDD pin			3	20	uA
I <sub>VDD_op</sub>	Operation Current			0.8	1.5	mA
I <sub>VDD_standby</sub>	Standby Current			0.5	1	mA
V <sub>DD_ON</sub>	VDD Under Voltage Lockout Exit		7.5	8.8	10	V
V <sub>DD_OFF</sub>	VDD Under Voltage Lockout Enter		3	3.6	4.5	V
V <sub>DD_OVP</sub>	VDD OVP Threshold		23	24.5	26	V
V <sub>DD_Clamp</sub>	VDD Zener Clamp Voltage	I(V <sub>DD</sub> ) = 7 mA	29	30.5	32	V
<b>Control Function Section (FB Pin)</b>						
V <sub>FBREF</sub>	Internal Error Amplifier (EA)		1.23	1.25	1.27	V

	Reference Input					
$V_{FB\_SLP}$	Short Load Protection (SLP) Threshold			0.4		V
$T_{FB\_Short}$	Short Load Protection (SLP) Debounce Time	(Note 3)		36		ms
$V_{FB\_DEM}$	Demagnetization Comparator Threshold			25		mV
$T_{off\_min}$	Minimum OFF time	(Note 3)		2		us
$T_{on\_max}$	Maximum ON time	(Note 3)		20		us
$T_{off\_max}$	Maximum OFF time			2.8		ms
$I_{Cable\_max}$	Maximum Cable Drop Compensation(CDC) Current			85		uA
$T_{SW} / T_{DEM}$	Ratio between Switching Period and Demagnetization Time in CC Mode			7/4		
<b>Current Sense Input Section (CS Pin)</b>						
$T_{LEB}$	CS Input Leading Edge Blanking Time			500		ns
$V_{cs(max)}$	Current limiting threshold		490	500	510	mV
$T_{D\_OC}$	Over Current Detection and Control Delay			100		ns
<b>On-Chip Thermal Shutdown</b>						
$T_{SD}$	Thermal Shutdown	(Note 3)	---	155	--	°C
$T_{RC}$	Thermal Recovery	(Note 3)		140	--	°C
<b>Power BJT Section (C Pin)</b>						
$I_C$	Maximum DC Collector Current	KP2130		0.8		A
		KP2131		1.8		A
		KP2132			4	
$V_{CE(sat)}$	Collector-Emitter Saturation Voltage	$I_C=0.5A$		0.3		V
$h_{FE}$	DC Current Gain		15	20		
$V_{CBO}$	Collector-Base Breakdown Voltage		800			V

**Note1.** Stresses listed as the above “Maximum Ratings” may cause permanent damage to the device. These are for stress ratings. Functional operation of the device at these or any other conditions beyond those indicated in the operational sections of the specifications is not implied. Exposure to maximum rating conditions for extended periods may remain possibility to affect device reliability.

**Note2.** The device is not guaranteed to function outside its operating conditions.

**Note3.** Guaranteed by the Design.

### Characterization Plots

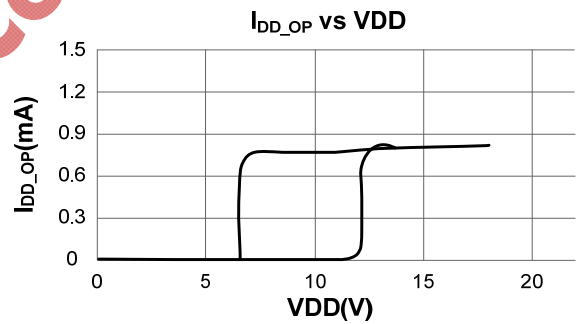
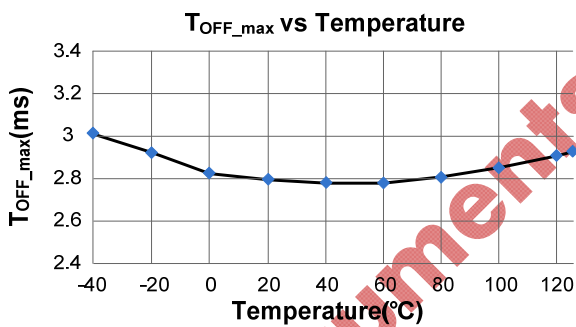
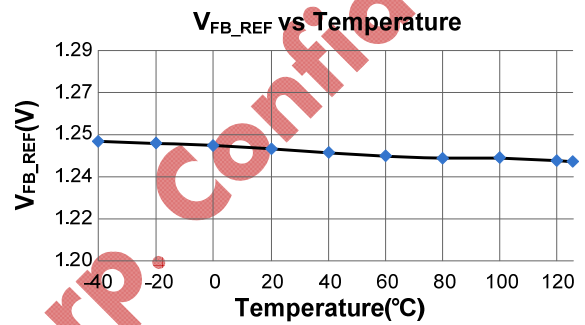
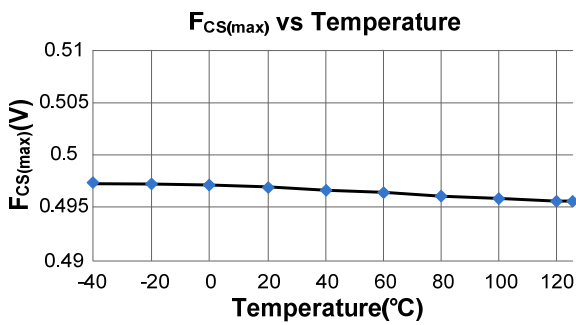
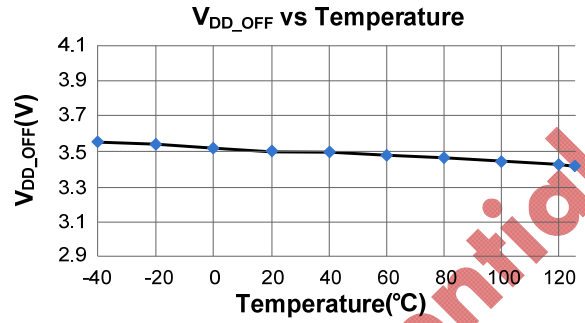
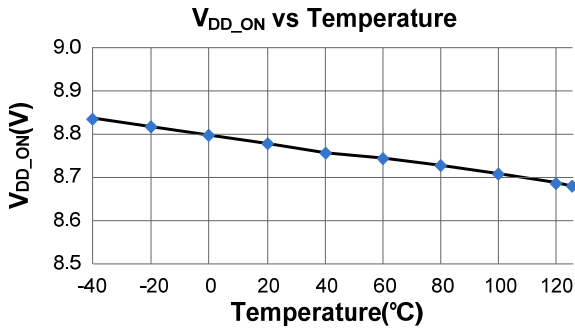

### Operation Description

KP213X is a high performance, multi mode, highly integrated Quasi Resonant Primary Side Regulation (QR-PSR) power switch. The built-in high precision CV/CC control with high level protection features makes it suitable for offline small power converter applications.

- **System Start-Up Operation**

Before the IC starts to work, it consumes only startup current (typically 3uA) which allows a large value startup resistor to be used to minimize the power loss and the current flowing through the startup resistor charges the VDD hold-up capacitor from the high voltage DC bus. When VDD reaches UVLO turn-on voltage of 8.8V (typical), KP213X begins switching and the IC operation current is increased to be 0.8mA (typical). The hold-up capacitor continues to supply VDD before the auxiliary winding of the transformer takes the control of VDD voltage.

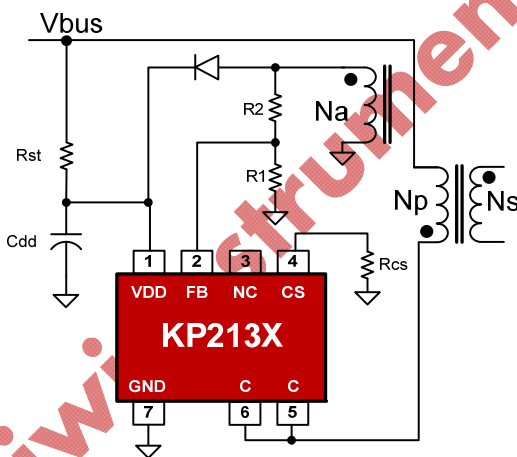

Fig.1

Once KP213X enters very low frequency FM (Frequency Modulation) mode, the operating current is reduced to be 500uA typically, which helps to reduce the standby power loss.

- **Quasi Resonant PSR CV Modulation (QR-CVM)**

In Primary Side Regulation (PSR) control, the output voltage is sensed on the auxiliary winding during the transfer of transformer energy to the secondary. Fig.2 illustrates the timing waveform of CV sampling signal, demagnetization signal (DEM) and quasi-resonant (QR) trigger signal in KP213X. When the CV sampling process is over, the internal sample/hold (S&H) circuit captures the error signal and amplifies it through the internal Error Amplifier (EA). The output of EA is sent to the Quasi Resonant PSR CV Modulator (QR-CVM) for CV regulation. A valley is selected to trigger new PWM cycle by the output of the QR-CVM block, which is determined by the load. The internal reference voltage for EA is trimmed to 1.3V with high accuracy.

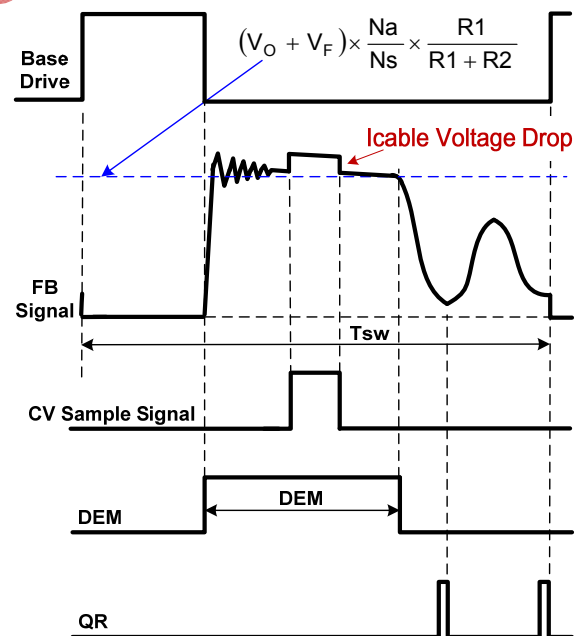

Fig.2

During the CV sampling process, an internal variable current source is flowing to FB pin for Cable Drop Compensation (CDC). Thus, there is a step at FB pin in the transformer demagnetization process, as shown in Fig.2. Fig.2

also illustrates the equation for “demagnetization plateau”, where  $V_o$  and  $V_F$  is the output voltage and diode forward voltage;  $R_1$  and  $R_2$  is the resistor divider connected from the auxiliary winding to FB Pin,  $N_s$  and  $N_a$  are secondary winding and auxiliary winding respectively.

When heavy load condition, the Mode Selector (as shown in “Block Diagram”) based on EA output will switch to CC Mode automatically.

### ● PSR Constant Current Modulation (PSR-CCM)

Timing information at the FB pin and current information at the CS pin allow accurate regulation of the secondary average current. The control law dictates that as power is increased in CV regulation and approaching CC regulation the primary peak current is at  $I_{pp(max)}$ , as shown in Fig.3.

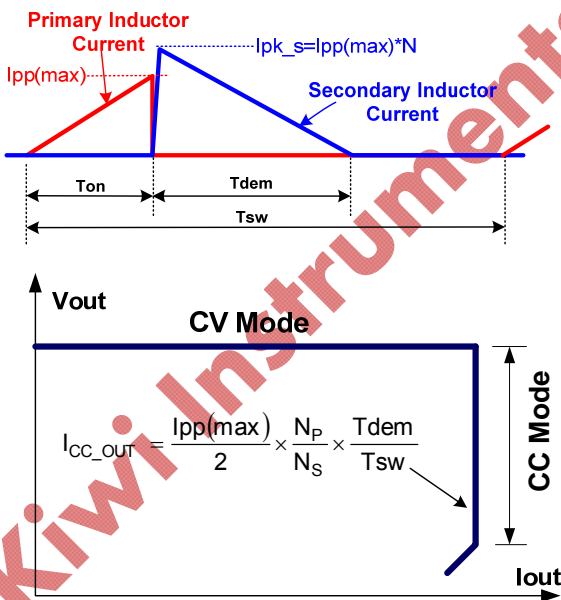

Fig.3

Referring to Fig.3 above, the primary peak current, transformer turns ratio, secondary

demagnetization time ( $T_{dem}$ ), and switching period ( $T_{sw}$ ) determines the secondary average output current  $I_{out}$ . Ignoring leakage inductance effects, the equation for average output current is shown in Fig.3. When the average output current  $I_{out}$  reaches the regulation reference in the Primary Side Constant Current Modulator (PSR-CCM) block, the IC operates in pulse frequency modulation (PFM) mode to control the output current at any output voltage at or below the voltage regulation target as long as the auxiliary winding can keep  $V_{DD}$  above the UVLO turn-off threshold.

In KP213X, the ratio between  $T_{dem}$  and  $T_{sw}$  in CC mode is 4/7. Therefore, the average output current can be expressed as:

$$I_{CC\_OUT}(mA) \cong \frac{2}{7} \times N \times \frac{500mV}{R_{cs}(\Omega)}$$

In the equation above,

$N$ ---The turn ratio of primary side winding to secondary side winding.

$R_{cs}$ --- the sensing resistor connected between the power BJT emitter to GND.

### ● Multi Mode Control in CV Mode

To meet the tight requirement of averaged system efficiency and no load power consumption, a hybrid of frequency modulation (FM) and amplitude modulation (AM) is adopted in KP213X which is shown in the Fig 4.

Around the full load, the system operates in FM mode. When normal to light load conditions, the IC operates in FM+AM mode to achieve excellent regulation and high efficiency. When the system is near zero loading, the IC operates in FM again for



standby power reduction. In this way, the no-load consumption can be less than 70mW.

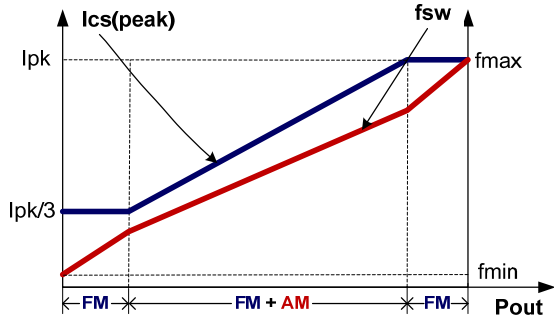

Fig.4

### ● Programmable Cable Drop Compensation (CDC) in CV Mode

In smart phone charger application, the battery is always connected to the adapter with a cable wire which can cause several percentages of voltage drop on the actual battery voltage. In KP213X, an offset voltage is generated at FB pin by an internal current source (modulated by CDC block, as shown in Fig.5) flowing into the resistor divider. The current is proportional to the switching period, thus, it is inversely proportional to the output power  $P_{out}$ . Therefore, the drop due the cable loss can be compensated. As the load decreases from full loading to zero loading, the offset voltage at FB pin will increase. By adjusting the resistance of R1 and R2 (as shown in Fig.5), the cable loss compensation can be programmed. The percentage of maximum compensation is given by

$$\frac{\Delta V(\text{cable})}{V_{out}} \approx \frac{I_{\text{cable\_max}} \times (R1/R2)}{V_{FB\_REF}} \times 100\%$$

For example,  $R1=3K\Omega$ ,  $R2=18K\Omega$ , The percentage of maximum compensation is given by:

$$\frac{\Delta V(\text{cable})}{V_{out}} = \frac{85\mu A \times (3K/18K)}{2V} \times 100\% = 10.9\%$$

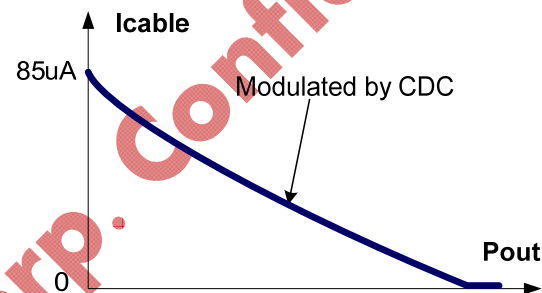
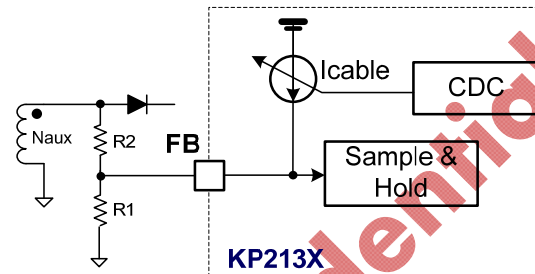

Fig.5

### ● Fast Dynamic Response

In KP213X, the dynamic response performance is optimized to meet USB charge requirements.

### ● On Chip Thermal Shutdown (OTP)

When the IC temperature is over  $155^{\circ}\text{C}$ , the IC shuts down. Only when the IC temperature drops to  $140^{\circ}\text{C}$ , IC will restart.

### ● Audio Noise Free Operation

As mentioned above, the multi-mode CV control with a hybrid of FM and AM provides frequency modulation. An internal current source flowing to CS pin realizes CS peak voltage modulation. In KP213X, the optimized combination of frequency modulation and CS peak voltage modulation algorithm can provide audio noise free operation

from full loading to zero loading.

- **Dynamic BJT Base Drive**

KP213X integrates a dynamic base drive control to optimize efficiency. The BJT base drive current ranges from 12mA to 50mA (typical), and is dynamically controlled according to the power supply load change. The higher the output power, the higher the based current. Specifically, the base current is related to CS peak voltage, as shown in Fig.6.

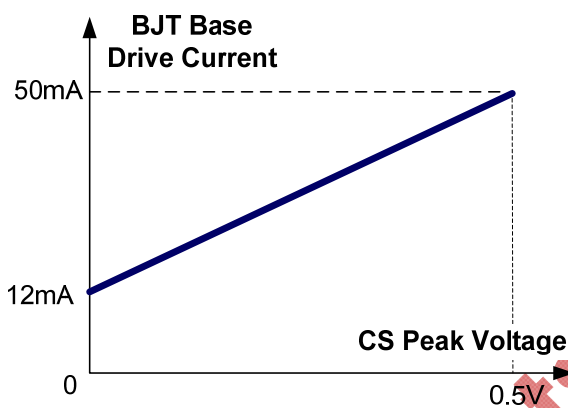

Fig.6

- **Short Load Protection (SLP)**

In KP213X, the output is sampled on FB pin and then compared with a threshold of UVP (0.4V typically) after an internal blanking time (36ms typical).

In KP213X, when sensed FB voltage is below 0.4V, the IC will enter into Short Load Protection (SLP) mode, in which the IC will enter into auto recovery protection mode.

- **VDD Over Voltage Protection (OVP) and Zener Clamp**

When VDD voltage is higher than 24.5V (typical), the IC will stop switching. This will cause VDD fall down to be lower than VDD\_OFF (typical 3.5V) and then the system will restart up again. An internal 30V (typical) zener clamp is integrated to prevent the IC from damage.

Package Dimension

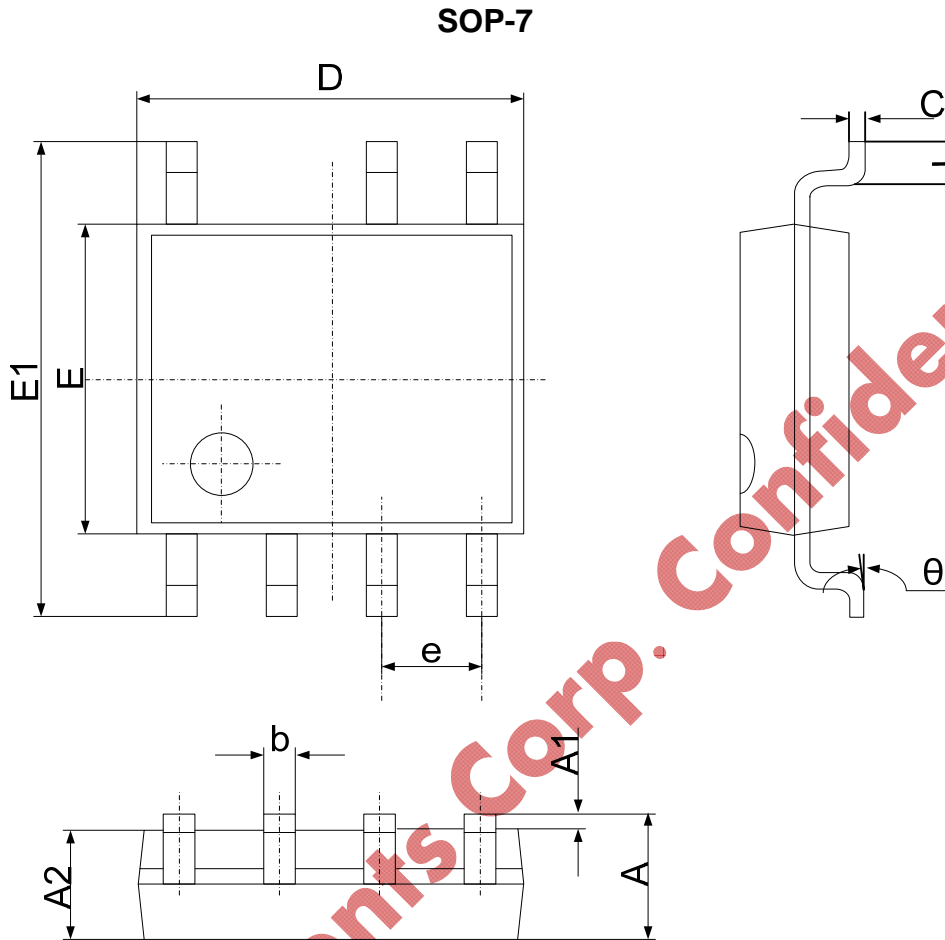

Symbol	Dimensions in Millimeters		Dimensions in Inches	
	Min	Max	Min	Max
A	1.350	1.750	0.053	0.069
A1	0.100	0.250	0.004	0.010
A2	1.350	1.550	0.053	0.061
b	0.330	0.510	0.013	0.020
c	0.170	0.250	0.006	0.010
D	4.700	5.100	0.185	0.200
E	3.800	4.000	0.150	0.157
E1	5.800	6.200	0.228	0.244
e	1.270 (BSC)		0.050 (BSC)	
L	0.400	1.270	0.016	0.050
θ	0°	8°	0°	8°



### Revision History

DATE	REV.	DESCRIPTION
2015/11/13	1.0	First Release
2016/05/06	1.01	Update the EC Table
2016/07/11	1.1	Part Number KP2131SGA is added
2016/09/13	1.2	Part Number KP2132SGA is added
2017/09/11	1.3	Update Ordering Information
2017/11/01	1.4	Update BJT Parameter
2017/12/04	1.5	Update $V_{FBREF}$ and $I_{Cable\_max}$ Value

### Contact Us:

#### US:

**Add:** 2060 Walsh Ave, Suite 244,  
Santa Clara, CA, 95050

**Tel:** 1-408-475-6888

**Fax:** 1-408-905-6912

**E-mail:** marketing@kiwiinst.com

#### Hangzhou:

**Add:** Room 1201, Building C, No.581  
HuoJu Rd., Binjiang Dist., Hangzhou,  
P.R.C

**Tel:** (86) 571-8795-8612

**Fax:** (86) 571-8795-5363

**E-mail:** marketing@kiwiinst.com.cn

#### Shenzhen:

**Add:** B302-B303, University  
Creative Park, Xili Rd., Nanshan  
Dist., Shenzhen, P.R.C

**Tel:** (86)755-8204-2689

**Fax:** (86)755-8204-2192

**E-mail:** marketing@kiwiinst.com.cn

### Disclaimer

Information that is provided by Kiwi Instruments Corporation is believed to be accurate and reliable. Kiwi instrument reserves the right to make any change in circuit design, specification or other related things if necessary without notice at any time. No third party intellectual property infringement of the applications should be guaranteed by users when integrating Kiwi instrument products into any application. No legal responsibility for any said applications is assumed by Kiwi Instrument.