

## HGV321/HGV358/HGV324

# 1MHz, 40uA, Rail-to-Rail I/O CMOS Operational Amplifier

### PRODUCT DESCRIPTION

The HGV321(single), HGV358(dual) and HGV324(quad) are rail-to-rail input and output voltage feedback amplifiers offering low cost. They have a wide input common-mode voltage range and output voltage swing, and take the minimum operating supply voltage down to 2.1V and the maximum recommended supply voltage is 5.5 V. All are specified over the extended - 40°C to +85°C temperature range.

The HGV321/358/324 provide 1MHz bandwidth at a low current consumption of 60µA per amplifier. Very low input bias currents of 10pA, enable HGV321/358/324 to be used for integrators, photodiode amplifiers, and piezoelectric sensors. Rail-to-rail inputs and outputs are useful to designers buffering ASIC in single-supply systems.

Applications for the series amplifiers include safety monitoring, portable equipment, battery and power supply control, and signal conditioning and interfacing for transducers in very low power systems.

The HGV321 is available in SOT23-5 and SC70-5 packages. The HGV358 comes in SO-8, MSOP-8 and PDIP-8 packages. The HGV324 is offered in SO-14, TSSOP-14, TSSOP-16 and SO-16 packages.

### APPLICATIONS

ASIC Input or Output Amplifier  
 Sensor Interface  
 Piezo Electric Transducer Amplifier  
 Medical Instrumentation  
 Mobile Communication  
 Audio Output  
 Portable Systems  
 Smoke Detectors  
 Notebook PC  
 PCMCIA cards  
 Battery -Powered equipment  
 DSP interface

### FEATURES

- Low Cost
- Rail-to-Rail Input and Output  
0.8mV Typical  $V_{os}$
- Unity Gain Stable
- Gain Bandwidth Product: 1MHz
- Very Low Input Bias Currents: 1pA
- Operates on 2.1 V to 5.5 V Supplies
- Input Voltage Range:  
- 0.1 V to +5.6 V with  $V_s = 5.5$  V
- Low Supply Current: 40µA/Amplifier
- Small Packaging

HGV321 Available in SOT23-5 and SC70-5

HGV358 Available in SO-8, MSOP-8 and PDIP-8

HGV324 Available in SO-14, SO-16, TSSOP-14 and TSSOP-16

### PIN CONFIGURATIONS (Top View)

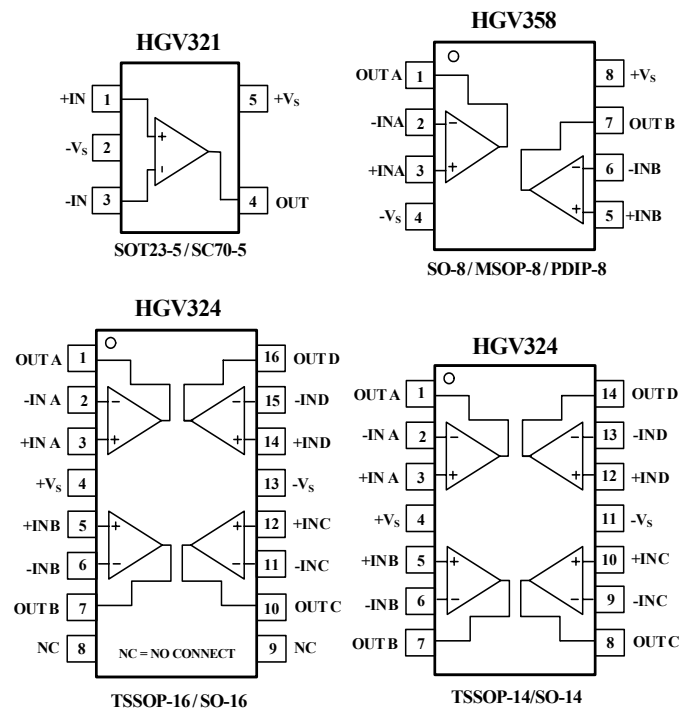

## ELECTRICAL CHARACTERISTICS : $V_S = +5V$

(At  $R_L = 100k\Omega$  connected to  $V_S/2$ , and  $V_{OUT} = V_S/2$ , unless otherwise noted)

PARAMETER	CONDITION	HGV321/358/324					
		TYP	MIN/MAX OVER TEMPERATURE			UNITS	MIN/MAX
		+25°C	+25°C	-40°C to 85°C			
<b>INPUT CHARACTERISTICS</b>							
Input Offset Voltage ( $V_{OS}$ )		±0.8	±5	±5.6	mV	MAX	
Input Bias Current ( $I_B$ )		1			pA	TYP	
Input Offset Current ( $I_{OS}$ )		1			pA	TYP	
Common-Mode Voltage Range ( $V_{CM}$ )	$V_S = 5.5V$	- 0.1 to + 5.6			V	TYP	
Common-Mode Rejection Ratio (CMRR)	$V_S = 5.5V, V_{CM} = -0.1V$ to 4 V	70	62	62	dB	MIN	
	$V_S = 5.5V, V_{CM} = -0.1V$ to 5.6 V	68	56	55	dB	MIN	
Open-Loop Voltage Gain ( $A_{OL}$ )	$R_L = 5K\Omega, V_O = 0.1V$ to 4.9V	80	70	70	dB	MIN	
	$R_L = 100K\Omega, V_O = 0.035V$ to 4.965V	84	80	80	dB	MIN	
Input Offset Voltage Drift ( $\Delta V_{OS}/\Delta T$ )		2.7			$\mu V/^\circ C$	TYP	
<b>OUTPUT CHARACTERISTICS</b>							
Output Voltage Swing from Rail	$R_L = 100K\Omega$	0.008			V	TYP	
Output Current ( $I_{OUT}$ )	$R_L = 10K\Omega$	0.08			V	TYP	
		23	20	18.8	mA	MIN	
<b>POWER SUPPLY</b>							
Operating Voltage Range			2.1	2.5	V	MIN	
			5.5	5.5	V	MAX	
Power Supply Rejection Ratio (PSRR)	$V_S = +2.5V$ to + 5.5 V $V_{CM} = (-V_S) + 0.5$	82	60	58	dB	MIN	
Quiescent Current / Amplifier ( $I_Q$ )	$I_{OUT} = 0$	40	80	86	$\mu A$	MAX	
<b>DYNAMIC PERFORMANCE</b>							
Gain-Bandwidth Product (GBP)	$C_L = 100pF$	1			MHz	TYP	
Slew Rate (SR)	$G = +1, 2V$ Output Step	0.52			V/ $\mu s$	TYP	
Settling Time to 0.1% ( $t_S$ )	$G = +1, 2V$ Output Step	5.3			$\mu s$	TYP	
Overload Recovery Time	$V_{IN} \cdot Gain = V_S$	2.6			$\mu s$	TYP	
<b>NOISE PERFORMANCE</b>							
Voltage Noise Density ( $e_n$ )	$f = 1kHz$	27			$nV/\sqrt{Hz}$	TYP	
	$f = 10kHz$	20			$nV/\sqrt{Hz}$	TYP	

Specifications subject to change without notice.

## ABSOLUTE MAXIMUM RATINGS

Supply Voltage, V+ to V- .....	7.5 V
Common-Mode Input Voltage ..... (-Vs) - 0.5 V to (+Vs) +0.5V	
Storage Temperature Range .....	-65°C to +150°C
Junction Temperature .....	160°C
Operating Temperature Range .....	-45°C to +85°C
Package Thermal Resistance @ TA = 25°C	
SC70-5, $\theta_{JA}$ .....	333°C/W
SOT23-5, $\theta_{JA}$ .....	190°C/W
SO-8, $\theta_{JA}$ .....	125°C/W
MSOP-8, $\theta_{JA}$ .....	216°C/W
SO-16, $\theta_{JA}$ .....	82°C/W
TSSOP-16, $\theta_{JA}$ .....	105°C/W
Lead Temperature Range (Soldering 10 sec) .....	260°C
ESD Susceptibility	
HBM.....	4000V
MM.....	400V

## NOTES

1. Stresses above those listed under Absolute Maximum Ratings may cause permanent damage to the device. This is a stress rating only; functional operation of the device at these or any other conditions above those indicated in the operational section of this specification is not implied. Exposure to absolute maximum rating conditions for extended periods may affect device reliability.

## CAUTION

This integrated circuit can be damaged by ESD. Shengbang Micro-electronics recommends that all integrated circuits be handled with appropriate precautions. Failure to observe proper handling and installation procedures can cause damage.

ESD damage can range from subtle performance degradation to complete device failure. Precision integrated circuits may be more susceptible to damage because very small parametric changes could cause the device not to meet its published specifications.

# TYPICAL PERFORMANCE CHARACTERISTICS

At  $T_A = +25^\circ\text{C}$ ,  $V_S = +5\text{V}$ , and  $R_L = 100\text{k}\Omega$  connected to  $V_S/2$ , unless otherwise noted.

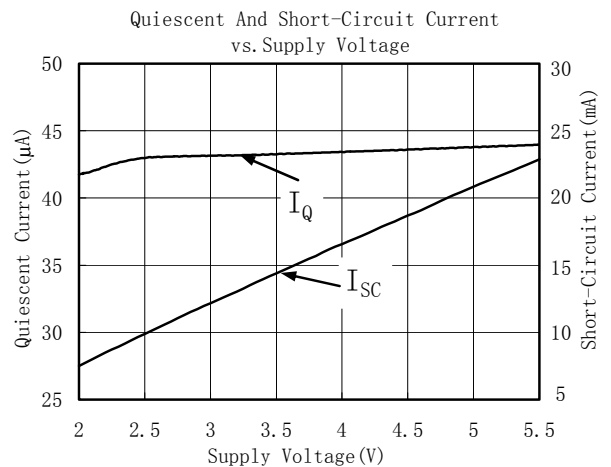
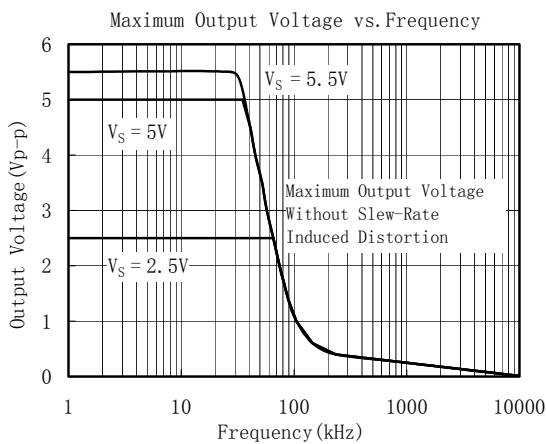
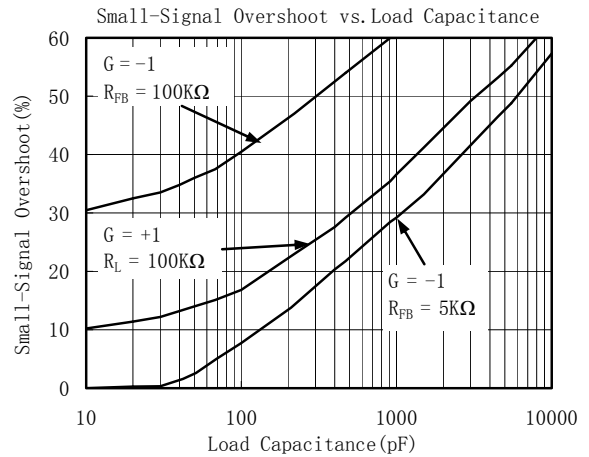
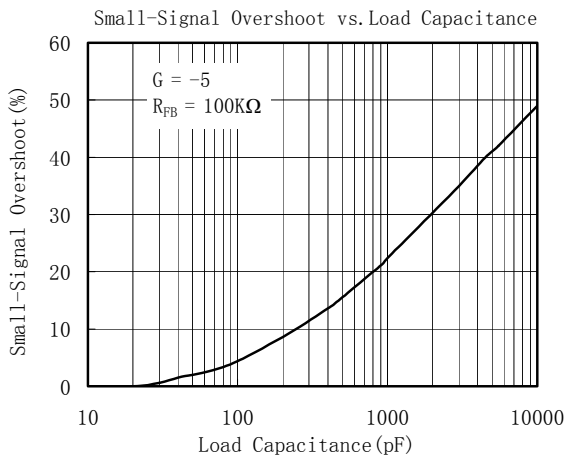
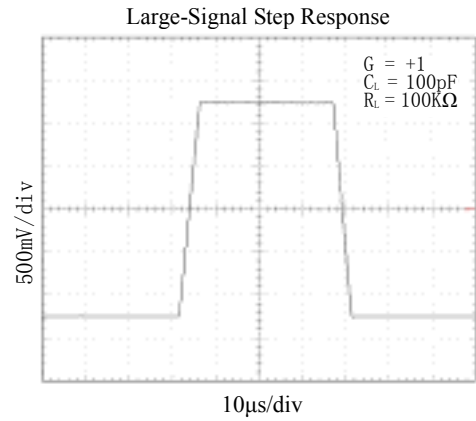
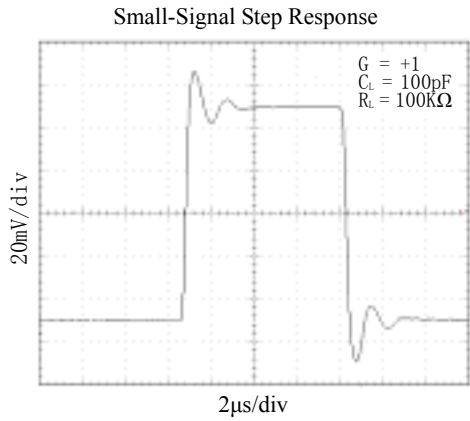

## TYPICAL PERFORMANCE CHARACTERISTICS

At  $T_A = +25^\circ\text{C}$ ,  $V_S = +5\text{V}$ , and  $R_L = 100\text{k}\Omega$  connected to  $V_S/2$ , unless otherwise noted.

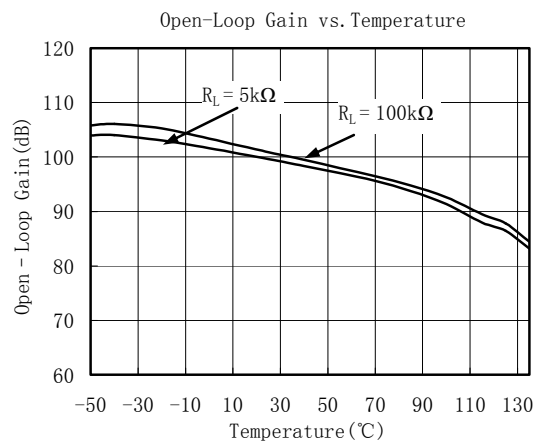
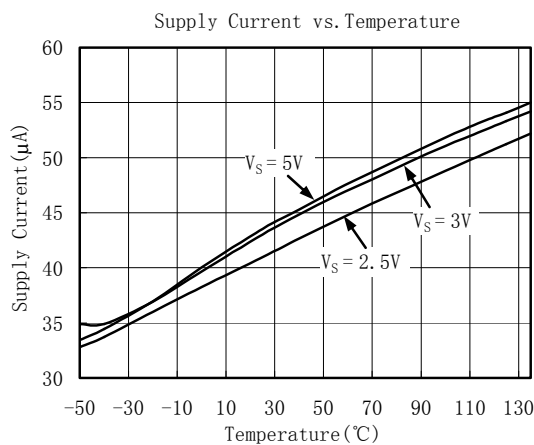
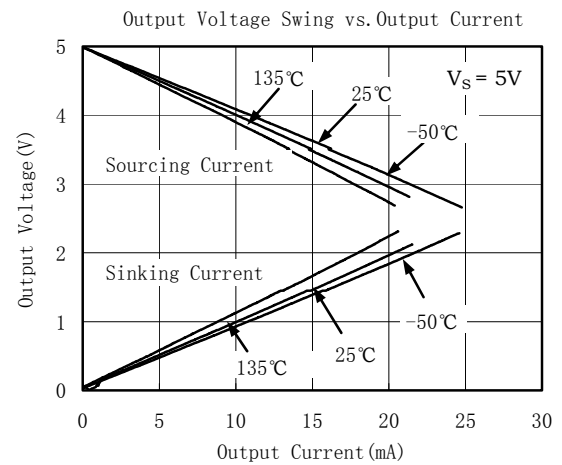
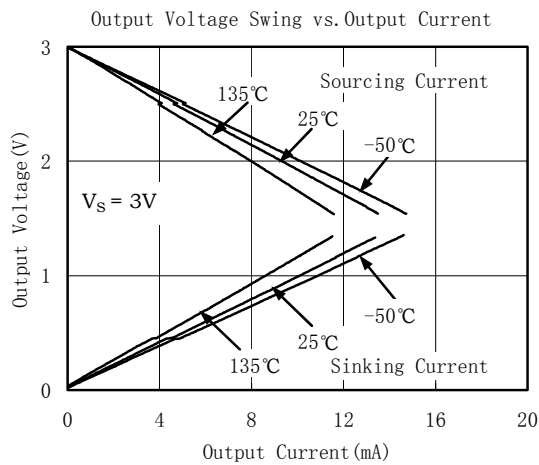
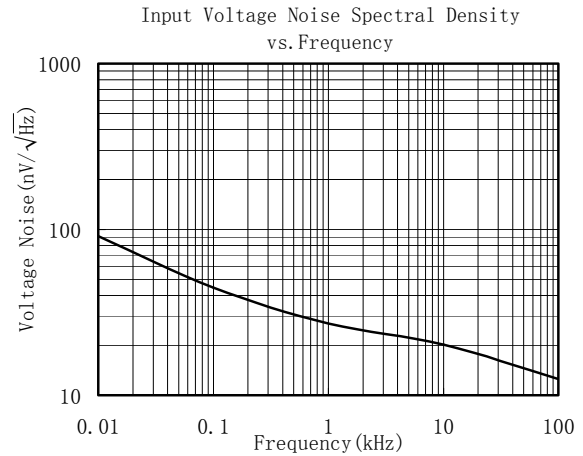
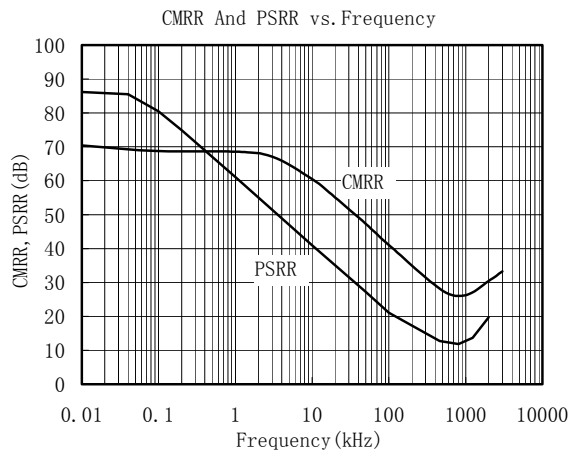

## TYPICAL PERFORMANCE CHARACTERISTICS

At  $T_A = +25^\circ\text{C}$ ,  $V_S = +5\text{V}$ , and  $R_L = 100\text{k}\Omega$  connected to  $V_S/2$ , unless otherwise noted.

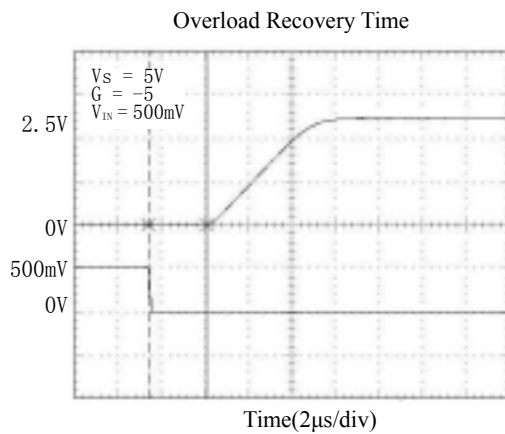
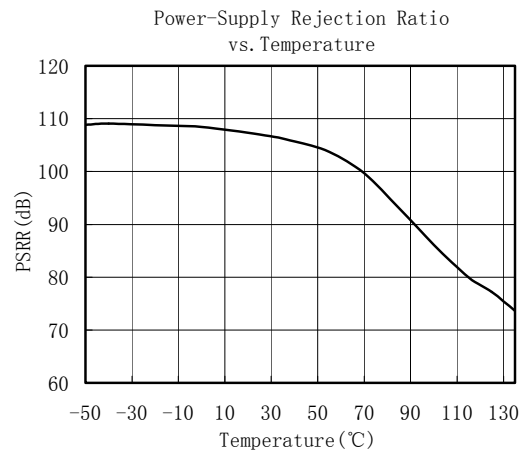
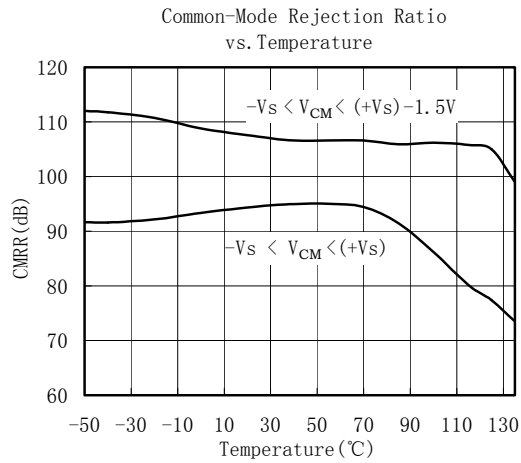

## APPLICATION NOTES

### Driving Capacitive Loads

The HGV3XX can directly drive 250pF in unity-gain without oscillation. The unity-gain follower (buffer) is the most sensitive configuration to capacitive loading. Direct capacitive loading reduces the phase margin of amplifiers and this results in ringing or even oscillation. Applications that require greater capacitive drive capability should use an isolation resistor between the output and the capacitive load like the circuit in Figure 1. The isolation resistor  $R_{ISO}$  and the load capacitor  $C_L$  form a zero to increase stability. The bigger the  $R_{ISO}$  resistor value, the more stable  $V_{OUT}$  will be. Note that this method results in a loss of gain accuracy because  $R_{ISO}$  forms a voltage divider with the  $R_{LOAD}$ .

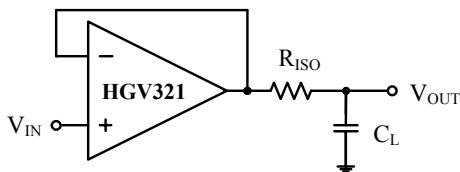

**Figure 1. Indirectly Driving Heavy Capacitive Load**

An improvement circuit is shown in Figure 2. It provides DC accuracy as well as AC stability.  $R_F$  provides the DC accuracy by connecting the inverting signal with the output,  $C_F$  and  $R_{ISO}$  serve to counteract the loss of phase margin by feeding the high frequency component of the output signal back to the amplifier's inverting input, thereby preserving phase margin in the overall feedback loop.

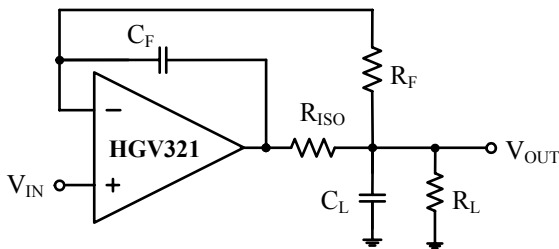
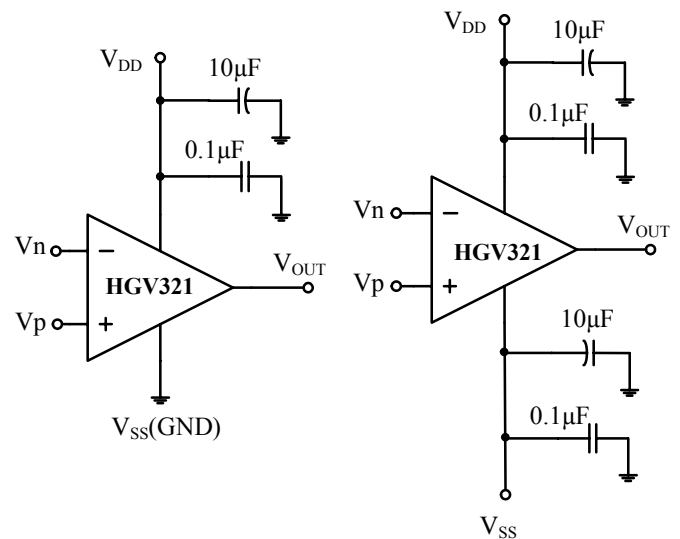

**Figure 2. Indirectly Driving Heavy Capacitive Load with DC Accuracy**

For no-buffer configuration, there are two others ways to increase the phase margin: (a) by increasing the amplifier's gain or (b) by placing a capacitor in parallel with the feedback resistor to counteract the parasitic capacitance associated with inverting node.

### Power-Supply Bypassing and Layout

The HGV3XX family operates from either a single +2.5V to +5.5V supply or dual  $\pm 1.25V$  to  $\pm 2.75V$  supplies. For single-supply operation, bypass the power supply  $V_{DD}$  with a  $0.1\mu F$  ceramic capacitor which should be placed close to the  $V_{DD}$  pin. For dual-supply operation, both the  $V_{DD}$  and the  $V_{SS}$  supplies should be bypassed to ground with separate  $0.1\mu F$  ceramic capacitors.  $2.2\mu F$  tantalum capacitor can be added for better performance.



**Figure 3. Amplifier with Bypass Capacitors**

## Typical Application Circuits

### Differential Amplifier

The circuit shown in Figure 4 performs the difference function. If the resistors ratios are equal ( $R_4 / R_3 = R_2 / R_1$ ), then  $V_{OUT} = (V_p - V_n) \times R_2 / R_1 + V_{ref}$ .

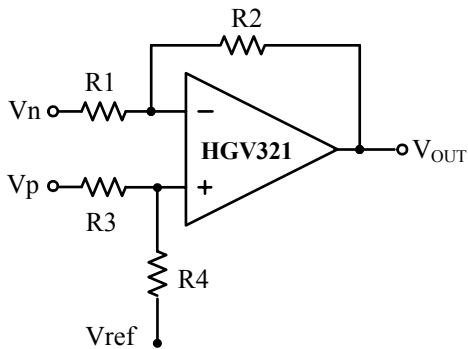

Figure 4. Differential Amplifier

### Instrumentation Amplifier

The circuit in Figure 5 performs the same function as that in Figure 4 but with the high input impedance.

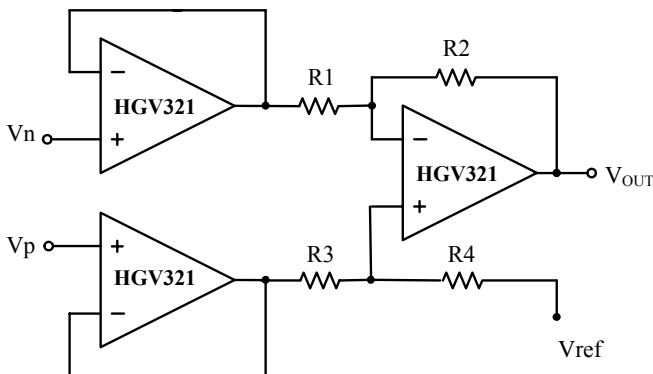

Figure 5. Instrumentation Amplifier

### Low Pass Active Filter

The low pass filter shown in Figure 6 has a DC gain of  $(-R_2 / R_1)$  and the  $-3\text{dB}$  corner frequency is  $1/2\pi R_2 C$ . Make sure the filter is within the bandwidth of the amplifier. The Large values of feedback resistors can couple with parasitic capacitance and cause undesired effects such as ringing or oscillation in high-speed amplifiers. Keep resistors value as low as possible and consistent with output loading consideration.

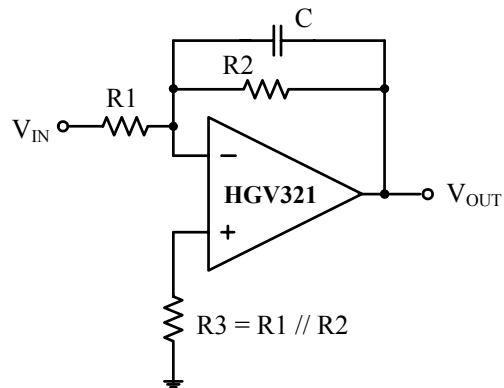

Figure 6. Low Pass Active Filter